

1. General description

The PN532 is a highly integrated transceiver module for contactless communication at 13.56 MHz based on the 80C51 microcontroller core. It supports 6 different operating modes:

- ISO/IEC 14443A/MIFARE Reader/Writer
- FeliCa Reader/Writer
- ISO/IEC 14443B Reader/Writer
- ISO/IEC 14443A/MIFARE Card MIFARE 1 KB or MIFARE 4 KB emulation
- FeliCa Card emulation
- ISO/IEC 18092, ECMA 340 Peer-to-Peer

The PN532 implements a demodulator and decoder for signals from ISO/IEC 14443A/MIFARE compatible cards and transponders. The PN532 handles the complete ISO/IEC 14443A framing and error detection (Parity & CRC).

The PN532 supports MIFARE 1 KB or MIFARE 4 KB emulation products. The PN532 supports contactless communication using MIFARE Higher transfer speeds up to 424 kbit/s in both directions.

The PN532 can demodulate and decode FeliCa coded signals. The PN532 handles the FeliCa framing and error detection. The PN532 supports contactless communication using FeliCa Higher transfer speeds up to 424 kbit/s in both directions.

The PN532 supports layers 2 and 3 of the ISO/IEC 14443 B Reader/Writer communication scheme, except anticollision. This must be implemented in firmware as well as upper layers.

In card emulation mode, the PN532 is able to answer to a Reader/Writer command either according to the FeliCa or ISO/IEC 14443A/MIFARE card interface scheme. The PN532 generates the load modulation signals, either from its transmitter or from the LOADMOD pin driving an external active circuit. A complete secure card functionality is only possible in combination with a secure IC using the NFC-WI/S²C interface.

Compliant to ECMA 340 and ISO/IEC 18092 NFCIP-1 Passive and Active communication modes, the PN532 offers the possibility to communicate to another NFCIP-1 compliant device, at transfer speeds up to 424 kbit/s. The PN532 handles the complete NFCIP-1 framing and error detection.

The PN532 transceiver can be connected to an external antenna for Reader/Writer or Card/PICC modes, without any additional active component.

The PN532 supports the following host interfaces:

- SPI
- I²C
- High Speed UART (HSU)

An embedded low-dropout voltage regulator allows the device to be connected directly to a battery. In addition, a power switch is included to supply power to a secure IC.

2. Features

- 80C51 microcontroller core with 40 KB ROM and 1 KB RAM
- Highly integrated demodulator and decoder
- Buffered output drivers to connect an antenna with minimum number of external components
- Integrated RF level detector
- Integrated data mode detector
- Supports ISO/IEC 14443A/MIFARE
- Supports ISO/IEC 14443B (Reader/Writer mode only)
- Typical operating distance in Reader/Writer mode for communication to ISO/IEC 14443A/MIFARE, ISO/IEC 14443B or FeliCa cards up to 50 mm depending on antenna size and tuning
- Typical operating distance in NFCIP-1 mode up to 50 mm depending on antenna size, tuning and power supply
- Typical operating distance in ISO/IEC 14443A/MIFARE or FeliCa card emulation mode of approximately 100 mm depending on antenna size, tuning and external field strength
- Supports MIFARE 1 KB or MIFARE 4 KB emulation encryption in Reader/Writer mode and MIFARE higher transfer speed communication at 212 kbit/s and 424 kbit/s
- Supports contactless communication according to the FeliCa protocol at 212 kbit/s and 424 kbit/s
- Integrated RF interface for NFCIP-1 up to 424 kbit/s
- Possibility to communicate on the RF interface above 424 kbit/s using external analog components
- Supported host interfaces
 - ◆ SPI interface
 - ◆ I²C interface
 - ◆ High-speed UART
- Dedicated host interrupts
- Low power modes
 - ◆ Hard-Power-Down mode (1 μ A typical)
 - ◆ Soft-Power-Down mode (22 μ A typical)
- Automatic wake-up on I²C, HSU and SPI interfaces when device is in Power-down mode
- Programmable timers
- Crystal oscillator
- 2.7 to 5.5 V power supply operating range
- Power switch for external secure companion chip
- Dedicated IO ports for external device control
- Integrated antenna detector for production tests
- ECMA 373 NFC-WI interface to connect an external secure IC

3. Applications

- Mobile and portable devices
- Consumer applications

4. Quick reference data

Table 1. Quick reference data

Symbol	Parameter	Conditions	Min	Typ	Max	Unit
V _{BAT}	Battery supply voltage		2.7		5.5	V
ICV _{DD}	LDO output voltage	V _{BAT} > 3.4 V V _{SS} = 0 V	[1] 2.7	3	3.4	V
PV _{DD}	Supply voltage for host interface	V _{SS} = 0 V	1.6		3.6	V
SV _{DD}	Output voltage for secure IC interface	V _{SS} = 0 V (SV _{DD} Switch Enabled)	DV _{DD} -0.5		DV _{DD}	V
I _{HPD}	Hard-Power-Down current consumption	V _{BAT} = 5 V		2		μA
I _{SPD}	Soft-Power-Down current consumption	V _{BAT} = 5 V, RF level detector on		45		μA
IDVDD	Digital supply current	V _{BAT} = 5 V, SV _{DD} switch off	[1]	25		mA
ISVDD	SV _{DD} load current	V _{BAT} = 5 V, SV _{DD} switch on		30		mA
I _{AVDD}	Analog supply current	V _{BAT} = 5 V		6		mA
ITVDD	Transmitter supply current	During RF transmission, V _{BAT} = 5 V		60[3]	150[4]	mA
P _{tot}	Continuous total power dissipation	T _{amb} = -30 to +85 °C	[2]		0.5	W
T _{amb}	Operating temperature range		-30		+85	°C

[1] DV_{DD}, AV_{DD} and TV_{DD} must always be at the same supply voltage.

[2] The total current consumption depends on the firmware version (different internal IC clock speed)

[3] With an antenna tuned at 50 Ω at 13.56 MHz

[4] The antenna should be tuned not to exceed this current limit (the detuning effect when coupling with another device must be taken into account)

5. Ordering information

Table 2. Ordering information

Type number	Package		
	Name	Description	Version
PN5320A3HN/C1xx ^{[1][4]}	HVQFN40	Heatsink Very thin Quad Flat package; 40 pins, plastic, body 6 x 6 x 0.85 mm; leadless; MSL level 2 ^[3] .	SOT618-1
PN5321A3HN/C1xx ^{[1][2][4]}	HVQFN40	Heatsink Very thin Quad Flat package; 40 pins, plastic, body 6 x 6 x 0.85 mm; leadless; MSL level 2 ^[3] .	SOT618-1

- [1] xx refers to the ROM code version. The ROM code functionalities are described in the User-Manual document. Each ROM code has its own User-Manual.
- [2] Type B software enabled. This NXP IC is licensed under Innovatron's ISO/IEC 14443 Type B patent license.
- [3] This is tested according the joint IPC/JEDEC standard J-STD-020C of July 2004.
- [4] Purchase of an NXP Semiconductors IC that complies with one of the NFC Standards (ISO/IEC18.092; ISO/IEC21.481) does not convey an implied license under any patent right on that standards. A license for the portfolio of the NFC Standards patents of NXP B.V. needs to be obtained at Via Licensing, the pool agent of the NFC Patent Pool, e-mail: info@vialicensing.com.

6. Block diagram

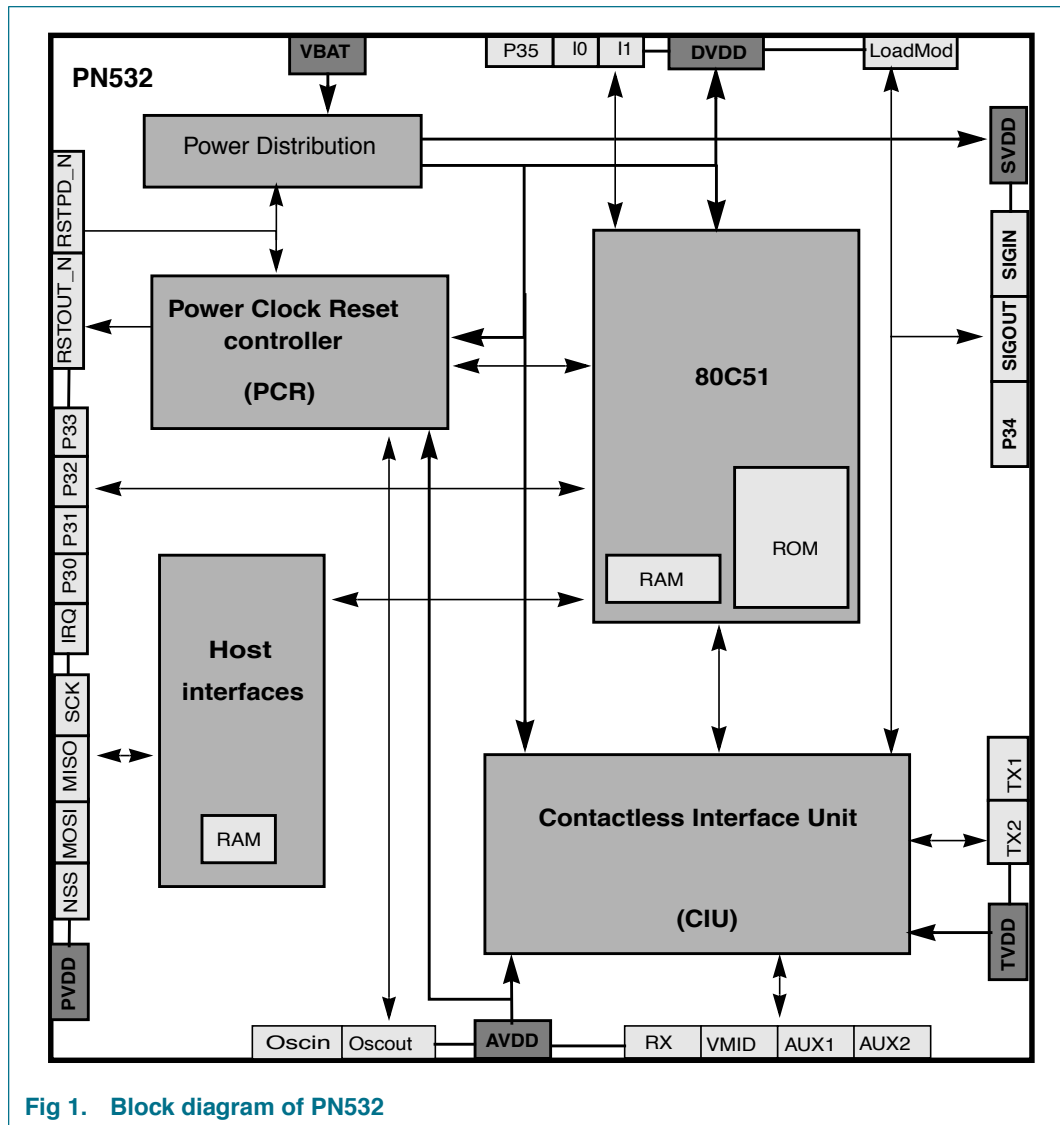

7. Pinning information

7.1 Pinning

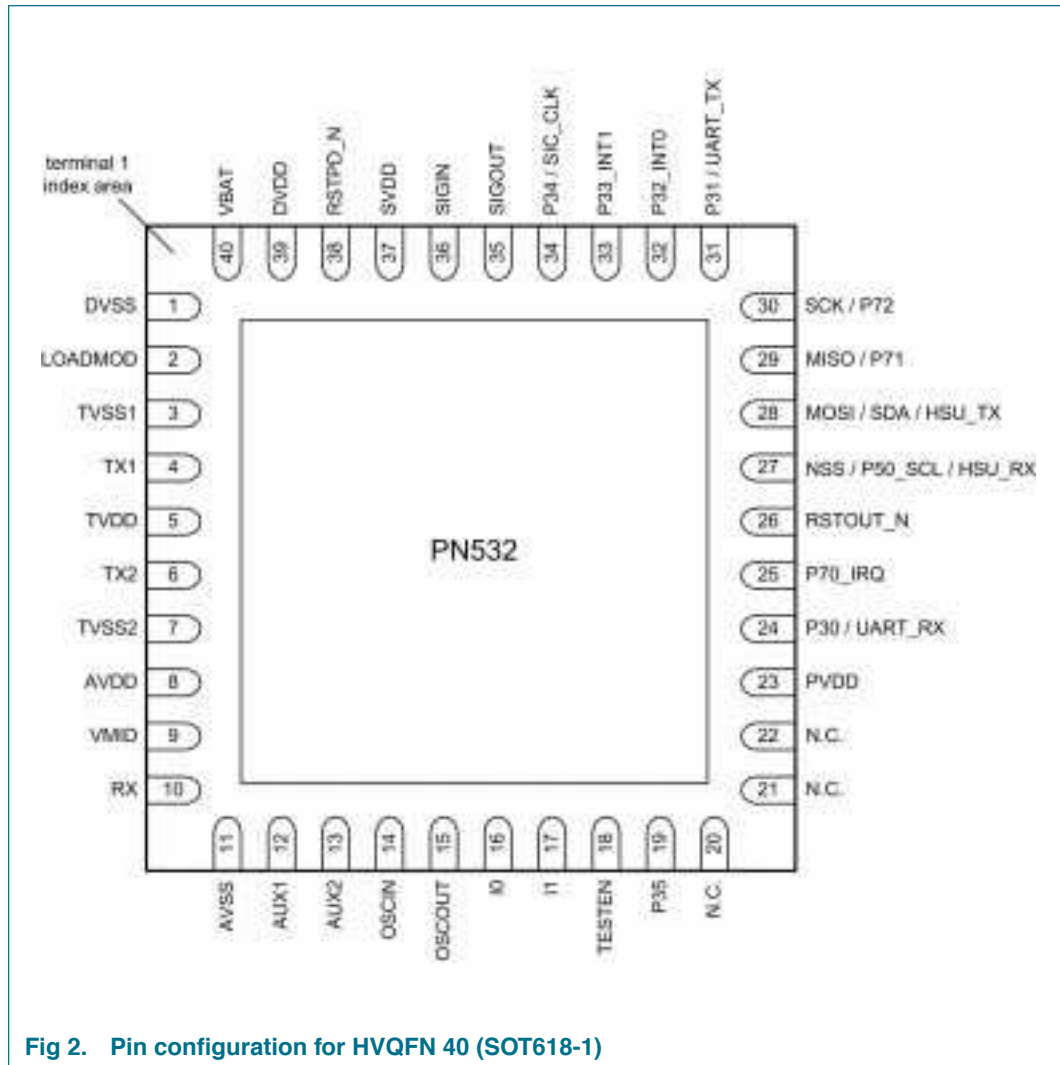

Fig 2. Pin configuration for HVQFN 40 (SOT618-1)

7.2 Pin description

Table 3. PN532 Pin description

Symbol	Pin	Type	Ref Voltage	Description
DVSS	1	PWR		Digital ground.
LOADMOD	2	O	DVDD	Load modulation signal.
TVSS1	3	PWR		Transmitter ground.
TX1	4	O	TVDD	Transmitter output 1: transmits modulated 13.56 MHz energy carrier.
TVDD	5	PWR		Transmitter power supply.
TX2	6	O	TVDD	Transmitter output 2: transmits modulated 13.56 MHz energy carrier.
TVSS2	7	PWR		Transmitter ground.
AVDD	8	PWR		Analog power supply.
VMID	9	O	AVDD	Internally generated reference voltage to bias the receiving path
RX	10	I	AVDD	Receiver input.
AVSS	11	PWR		Analog ground.
AUX1	12	O	AVDD	Auxiliary output 1: analog and digital test signals.
AUX2	13	O	AVDD	Auxiliary output 2: analog and digital test signals.
OSCIN	14	I	AVDD	Crystal oscillator input: to oscillator inverting amplifier.
OSCOU	15	O	AVDD	Crystal oscillator output: from oscillator inverting amplifier.
I0	16	I	DVDD	Host interface selector 0.
I1	17	I	DVDD	Host interface selector 1.
TESTEN	18	I	DVDD	Reserved for test: connect to ground for normal operation.
P35	19	IO	DVDD	General purpose IO.
N.C.	20			Not connected.
N.C.	21			Not connected.
N.C.	22			Not connected.
PVDD	23	PWR		Pad power supply.
P30 / UART_RX	24	IO	PVDD	General purpose IO / Debug UART receive input.
P70_IRQ	25	IO	PVDD	General purpose IO. Can be used as Interrupt request to host.
RSTOUT_N	26	O	PVDD	Reset indicator: when low, circuit is in reset state.
NSS / P50_SCL / HSU_RX	27	IO	PVDD	Host interface pin: SPI Not Slave Selected (NSS) or I ² C clock (SCL) or HSU receive (HSU_RX). Refer to Table 72 on page 48 for details.
MOSI / SDA / HSU_TX	28	IO	PVDD	Host interface pin: SPI Master Out Slave In (MOSI) or I ² C data (SDA) or HSU transmit (HSU_TX). Refer to Table 72 on page 48 for details.
MISO / P71	29	IO	PVDD	Host interface pin: SPI Master In Slave Out (MISO). Refer to Table 72 on page 48 for details. Can be used as general purpose IO.

Table 3. PN532 Pin description ...continued

Symbol	Pin	Type	Ref Voltage	Description
SCK / P72	30	IO	PVDD	Host interface pin: SPI serial clock. Refer to Table 72 on page 48 for details. Can be used as general purpose IO.
P31 / UART_TX	31	IO	PVDD	General purpose IO/ Debug UART TX.
P32_INT0	32	IO	PVDD	General purpose IO / Interrupt source INT0.
P33_INT1	33	IO	PVDD	General purpose IO / Interrupt source INT1.
P34 / SIC_CLK	34	IO	SVDD	General purpose IO / Secure IC clock.
SIGOUT	35	O	SVDD	Contactless communication interface output: delivers a serial data stream according to NFCIP-1 to a secure IC.
SIGIN	36	I	SVDD	Contactless communication interface input: accepts a serial data stream according to NFCIP-1 and from a secure IC.
SVDD	37	O		Switchable output power for secure IC power supply with overload detection. Used as a reference voltage for secure IC communication.
RSTPD_N	38	I	PVDD	Reset and Power-Down: When low, internal current sources are switched off, the oscillator is disabled, and input pads are disconnected from the outside world. The internal reset phase starts on the negative edge on this pin.
DVDD	39	O		Internal digital power supply.
VBAT	40	PWR		Main external power supply.

8. Functional description

8.1 80C51

The PN532 is controlled via an embedded 80C51 microcontroller core (for more details <http://www.standardics.nxp.com/support/documents/microcontrollers/?scope=80C51>). Its principle features are listed below:

- 6-clock cycle CPU. One machine cycle comprises 6 clock cycles or states (S1 to S6). An instruction needs at least one machine cycle.
- ROM interface
- RAM interface to embedded IDATA and XRAM memories (see [Figure 4 on page 11](#))
- Peripheral interface (PIF)
- Power control module to manage the CPU power consumption
- Clock module to control CPU clock during Shutdown and Wake-up modes
- Port module interface to configure I/O pads
- Interrupt controller
- Three timers
- Debug UART

The block diagram describes the main blocks described in this 80C51 section.

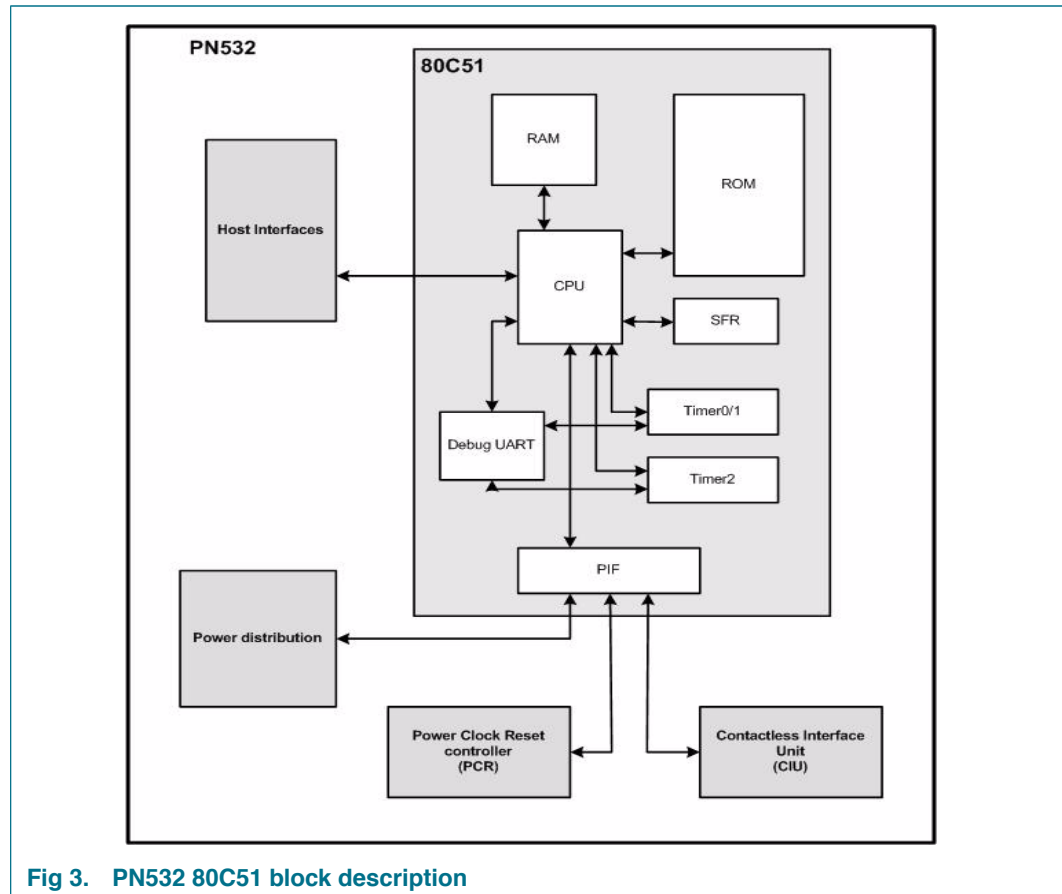

Fig 3. PN532 80C51 block description

8.1.1 PN532 memory map

The memory map of PN532 is composed of 2 main memory spaces: data memory and program memory. The following figure illustrates the structure.

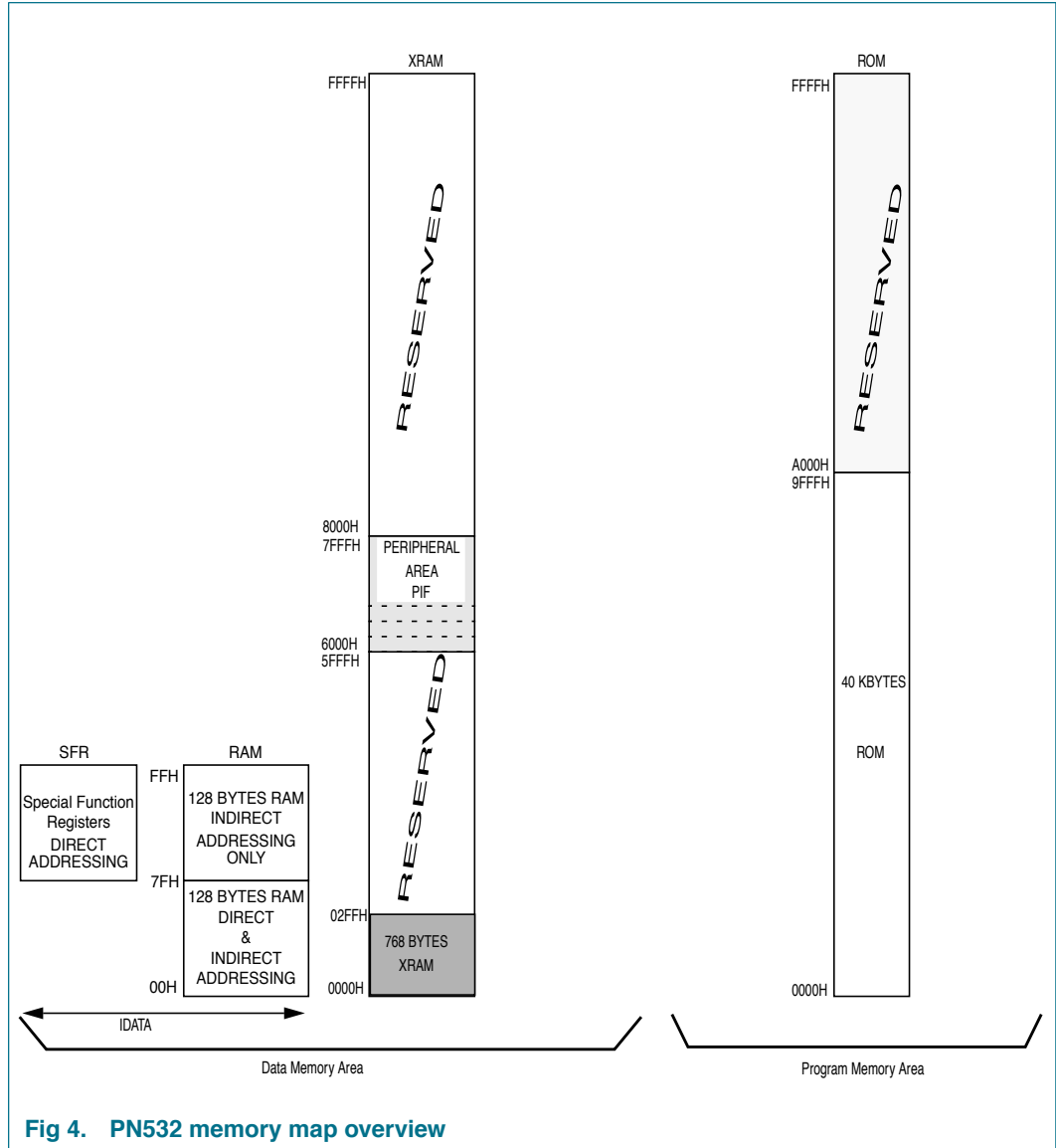

Fig 4. PN532 memory map overview

8.1.2 Data memory

Data memory is itself divided into 2 spaces:

- 384-byte IDATA with byte-wide addressing
 - 258-byte RAM
 - 128-byte SFR
- 1 bank of 64 KB extended RAM (XRAM) with 2-byte-wide addressing

8.1.2.1 IDATA memory

The IDATA memory is mapped into 3 blocks, which are referred as Lower IDATA RAM, Upper IDATA RAM, and SFR. Addresses to these blocks are byte-wide, which implies an address space of only 256 bytes. However, 384 bytes can be addressed within IDATA memory through the use of direct and indirect address mechanisms.

- Direct addressing: the operand is specified by an 8-bit address field in the instruction.
- Indirect addressing: the instruction specifies a register where the address of the operand is stored.

For the range 80h to FFh, direct addressing will access the SFR space; indirect addressing accesses Upper IDATA RAM. For the range 0h0 to 7Fh, Lower IDATA RAM is accessed, regardless of addressing mode. This behavior is summarized in the table below:

Table 4. IDATA memory addressing

Address	Addressing mode	
	Direct	Indirect
00h to 7Fh	Lower IDATA RAM	Lower IDATA RAM
80h to FFh	SFRs	Upper IDATA RAM

The SFRs and their addresses are described in the [Table 5](#):

Table 5. SFR map of NFC controller

Address	Bit-addressable	Byte-addressable							Address
F8h	IP1		XRAMP		P3CFGA	P3CFGB			FFh
F0h	B				P7CFGA	P7CFGB		P7	F7h
E8h	IE1	CIU_Status2	CIU_FIFOData	CIU_FIFOLevel	CIU_WaterLevel	CIU_Control	CIU_BitFraming	CIU_Coll	EFh
E0h	ACC								E7h
D8h	I ² CC0N	I ² CSTA	I ² CDAT	I ² CADR				CIU_Status1	DFh
D0h	PSW	CIU_Command	CIU_CommIEEn	CIU_DivIEEn	CIU_CommIrq	CIU_DivIrq	CIU_Error		D7h
C8h	T2CON	T2MOD	RCAP2L	RCAP2H	T2L	T2H			CFh
C0h									C7h
B8h	IP0								BFh
B0h	P3								B7h
A8h	IE0	SPIcontrol	SPIstatus	HSU_STA	HSU_CTR	HSU_PRE	HSU_CNT		AFh
A0h		FITEN	FDATA	FSIZE					A7h
98h	S0CON	SBUF	RWL	TWL	FIFOFS	FIFOFF	SFF	FIT	9Fh
90h									97h
88h	T01CON	T01MOD	T0L	T1L	T0H	T1H			8Fh
80h		SP	DPL	DPH				PCON	87h

8.1.2.2 XRAM memory

The XRAM memory is divided into 2 memory spaces:

- 0000h to 5FFFh: reserved for addressing embedded RAM. For the PN532, only accesses between 0000h and 02FF are valid.
- 6000h to 7FFFh: reserved for addressing embedded peripherals. This space is divided into 32 regions of 256 bytes each. Addressing can be performed using R0 or R1 and the XRAMP SFR.

The [Table 6](#) depicts the mapping of internal peripherals into XRAM.

Table 6. Peripheral mapping into XRAM memory space

Base Address	End Address	Description
6000h	60FFh	Reserved.
6100h	61FFh	IOs and miscellaneous registers configuration Refer to Section 8.2 “General purpose IOs configurations” on page 38
6200h	62FFh	Power Clock and Reset controller Refer to Section 8.5.7 “PCR extension registers” on page 92
6300h	633Fh	Contactless Unit Interface Refer to Section 8.6 “Contactless Interface Unit (CIU)” on page 98
6340h	FFFFh	Reserved

XRAM is accessed via the dedicated MOVX instructions. There are two access modes:

- 16-bit data pointer (DPTR): the full XRAM address space can be accessed.
- paging mechanism: the upper address byte is stored in the SFR register XRAMP; the lower byte is stored in either R1 or R0.

The [Figure 5](#) illustrates both mechanisms.

8.1.4 PCON module

The Power Control (PCON) module is configured using the PCON SFR register.

Table 7. PCON register (SFR: address 87h) bit allocation

Bit	7	6	5	4	3	2	1	0
Symbol	SMOD			-			CPU_PD	-
Reset	0	0	0	0	0	0	0	0
Access	R/W	R	R	R	R	R	R/W	R/W

Table 8. Description of PCON bits

Bit	Symbol	Description
7	SMOD	Serial MODE: When set to logic 1, the baud rate of the Debug UART is doubled
6 to 3	-	Reserved.
1	CPU_PD	Power-down: When set to logic 1, the microcontroller goes in Power-down mode
0	Reserved	This bit should only ever contain logic 0.

8.1.5 Interrupt Controller

The interrupt controller has the following features:

- 13 interrupt sources
- Interrupt enable registers IE0 and IE1
- Interrupt priority registers IP0 and IP1
- Wake-up from Power-Down state

8.1.5.1 Interrupt vectors

The mapping between interrupt sources and interrupt vectors is shown in [Table 9](#).

Table 9. Interrupt vector

Interrupt number	Interrupt vector	Interrupt sources	Incremental priority level (conflict resolution level)
0	0003h	External P32_INT0	Highest
1	000Bh	Timer0 interrupt	
2	0013h	External P33_INT1	
3	001Bh	Timer1 interrupt	
4	0023h	Debug UART interrupt	
5	002Bh	Timer2 interrupt	
6	0033h	NFC-WI interrupt	
7	003Bh	LDO overcurrent interrupt	
8	0043h	Reserved	
9	004Bh	CIU interrupt 1	
10	0053h	CIU interrupt 0	
11	005Bh	I ² C interrupt	
12	0063h	SPI, FIFO, or HSU interrupts	
13	006Bh	Reserved	
14	0073h	General Purpose IRQ	Lowest

8.1.5.2 Interrupt enable: IE0 and IE1 registers

Each interrupt source can be individually enabled or disabled by setting a bit in IE0 or IE1. In register IE0, a global interrupt enable bit can be set to logic 0 to disable all interrupts at once.

The 2 following tables describe IE0.

Table 10. Interrupt controller IE0 register (SFR: address A8h) bit allocation

Bit	7	6	5	4	3	2	1	0
Symbol	IE0_7	IE0_6	IE0_5	IE0_4	IE0_3	IE0_2	IE0_1	IE0_0
Reset	0	0	0	0	0	0	0	0
Access	R/W	R/W	R/W	R/W	R/W	R/W	R/W	R/W

Table 11. Description of IE0 bits

Bit	Symbol	Description
7	IE0_7	Global interrupt enable When set to logic 1, the interrupts can be enabled. When set to logic 0, all the interrupts are disabled.
6	IE0_6	NFC-WI counter interrupt enable When set to logic 1, NFC-WI interrupt is enabled. See Table 164 on page 125 .
5	IE0_5	Timer2 interrupt enable When set to logic 1, Timer2 interrupt is enabled. See Table 36 on page 28 .
4	IE0_4	Debug UART interrupt enable When set to logic 1, Debug UART interrupt is enabled. See Table 49 on page 33 .
3	IE0_3	Timer1 interrupt enable When set to logic 1, Timer1 interrupt is enabled. See Table 23 on page 23 .
2	IE0_2	P33_INT1 interrupt enable When set to logic 1, P33_INT1 pin interrupt is enabled. See Table 23 on page 23 . The polarity of P33_INT1 can be inverted (see Table 73 on page 49).
1	IE0_1	Timer0 interrupt enable When set to logic 1, Timer0 interrupt is enabled. See Table 23 on page 23 .
0	IE0_0	P32_INT0 interrupt enable When set to logic 1, P32_INT0 pin interrupt is enabled. See Table 23 on page 23 .

The 2 following tables describe IE1.

Table 12. Interrupt controller IE1 register (SFR: address E8h) bit allocation

Bit	7	6	5	4	3	2	1	0
Symbol	IE1_7	-	IE1_5	IE1_4	IE1_3	IE1_2	-	IE1_0
Reset	0	0	0	0	0	0	0	0
Access	R/W	R/W	R/W	R/W	R/W	R/W	R/W	R/W

Table 13. Description of IE1 bits

Bit	Symbol	Description
7	IE1_7	General purpose IRQ interrupt enable. When set to logic 1, enables interrupt function of P34, P35, P50_SCL and P71 according to their respective enable and level control bits. See Table 19 on page 20 , Table 137 on page 94 and Table 143 on page 96 .
6	-	Reserved. This bit must be set to logic 0
5	IE1_5	FIFO, SPI and HSU interrupt enable. When set to logic 1, enables FIFO interrupts, SPI interrupts, HSU interrupt. In HSU mode, the interrupt is when NSS is at logic 0. For the FIFO interrupts, see Table 112 on page 75 . For the SPI interrupts, see Table 122 on page 80 .
4	IE1_4	I²C interrupt enable. When set to logic 1, enables I ² C interrupt. See Table 77 on page 54 .
3	IE1_3	CIU interrupt 0 enable. When set to logic 1, enables CIU interrupt 0: CIU_IRQ_0. See Table 190 on page 150 .
2	IE1_2	CIU interrupt 1 enable. When set to logic 1, enables the CIU interrupt 1: CIU_IRQ_1. See Table 190 on page 150 .
1	-	Reserved. This bit must be set to logic 0.
0	IE1_0	LDO overcurrent interrupt enable. When set to logic 1, enables the LDO overcurrent detection interrupt. See Table 127 on page 87 .

8.1.5.3 Interrupt prioritization: IP0 and IP1 registers

Each interrupt source can be individually programmed to be one of two priority levels by setting or clearing a bit in the interrupt priority registers IP0 and IP1. If two interrupt requests of different priority levels are received simultaneously, the request with the high priority is serviced first. On the other hand, if the interrupts are of the same priority, precedence is resolved by comparing their respective conflict resolution levels (see [Table 9 on page 16](#) for details). The processing of a low priority interrupt can be interrupted by one with a high priority.

A RETI (Return From Interrupt) instruction jumps to the address immediately succeeding the point at which the interrupt was serviced. The instruction found at the return address will be executed, prior to servicing any pending interrupts.

The 2 following tables describe IP0.

Table 14. Interrupt controller IP0 register (SFR: address B8h) bit allocation

Bit	7	6	5	4	3	2	1	0
Symbol	IP0_7	IP0_6	IP0_5	IP0_4	IP0_3	IP0_2	IP0_1	IP0_0
Reset	0	0	0	0	0	0	0	0
Access	R/W	R/W	R/W	R/W	R/W	R/W	R/W	R/W

Table 15. Description of IP0 bits

Bit	Symbol	Description
7	IP0_7	Reserved
6	IP0_6	When set to logic 1, NFC-WI interrupt is set to high priority.
5	IP0_5	When set to logic 1, Timer2 interrupt is set to high priority.
4	IP0_4	When set to logic 1, Debug UART interrupt is set to high priority.
3	IP0_3	When set to logic 1, Timer1 interrupt is set to high priority.
2	IP0_2	When set to logic 1, external P33_INT1 pin is set to high priority.
1	IP0_1	When set to logic 1, Timer0 interrupt is set to high priority.
0	IP0_0	When set to logic 1, external P32_INT0 pin is set to high priority.

The 2 following tables describe IP1.

Table 16. Interrupt controller IP1 register (SFR: address F8h) bit allocation

Bit	7	6	5	4	3	2	1	0
Symbol	IP1_7	-	IP1_5	IP1_4	IP1_3	IP1_2		-
Reset	0	0	0	0	0	0		00
Access	R/W	R/W	R/W	R/W	R/W	R/W		R/W

Table 17. Description of IP1 bits

Bit	Symbol	Description
7	IP1_7	When set to logic 1, General Purpose IRQ interrupt is set to high priority.
6	-	Reserved. This bit must be set to logic 0.
5	IP1_5	When set to logic 1, combined SPI, FIFO and HSU interrupt is set to high priority.
4	IP1_4	When set to logic 1, I ² C interrupt is set to high priority.
3	IP1_3	When set to logic 1, CIU interrupt 0 is set to high priority.
2	IP1_2	When set to logic 1, CIU interrupt 1 is set to high priority.
1	-	Reserved. This bit must be set to logic 0.
0	IP1_0	When set to logic 1, interrupt number 7 is set to high priority.

8.1.5.4 General purpose IRQ control

The general purpose interrupts are controlled by register GPIRQ.

NOTE: this is not a standard feature of the 8051.

Table 18. GPIRQ register (address 6107h) bit allocation

Bit	7	6	5	4	3	2	1	0
Symbol	gpirq_level_P71	gpirq_level_P50	gpirq_level_P35	gpirq_level_P34	gpirq_enable_P71	gpirq_enable_P50	gpirq_enable_P35	gpirq_enable_P34
Reset	0	0	0	0	0	0	0	0
Access	R/W	R/W	R/W	R/W	R/W	R/W	R/W	R/W

Table 19. Description of GPIRQ bits

Bit	Symbol	Description
7	gpirq_level_P71	Configures the polarity of signal on P71 to generate a GPIRQ interrupt event (assuming gpirq_enable_P71 is set). When set to logic 0, an interrupt will be generated if P71 is at logic 0. When set to logic 1, an interrupt will be generated if P71 is at logic 1.
6	gpirq_level_P50	Configures the polarity of signal on P50 to generate a GPIRQ interrupt event (assuming gpirq_enable_P50 is set). When set to logic 0, an interrupt will be generated if P50_SCL is at logic 0. When set to logic 1, an interrupt will be generated if P50_SCL is at logic 1.
5	gpirq_level_P35	Configures the polarity of signal on P35 to generate a GPIRQ interrupt event (assuming gpirq_enable_P35 is set). When set to logic 0, an interrupt will be generated if P35 is at logic 0. When set to logic 1, an interrupt will be generated if P35 is at logic 1.
4	gpirq_level_P34	Configures the polarity of signal on P34 to generate a GPIRQ interrupt event (assuming gpirq_enable_P34 is set). When set to logic 0, an interrupt will be generated if P34 is at logic 0. When set to logic 1, an interrupt will be generated if P34 is at logic 1. Remark: If hide_svdd_sig of the register control_rngpower is set and gpirq_enable_P34 is also set then this bit will be asserted independently of the level on the pad P34.
3	gpirq_enable_P71	When set to logic 1, enables pad P71 to generate a GPIRQ interrupt event. ^[1]
2	gpirq_enable_P50	When set to logic 1, enables pad P50_SCL to generate a GPIRQ interrupt event. ^[1]
1	gpirq_enable_P35	When set to logic 1, enables pad P35 to generate a GPIRQ interrupt event. ^[1]
0	gpirq_enable_P34	When set to logic 1, enables pad P34 to generate a GPIRQ interrupt event. ^[1]

[1] The bit IE1_7 of register IE1 (see [Table 13 on page 18](#)) has also to be set to logic 1 to enable the corresponding CPU interrupt.

8.1.6 Timer0/1 description

Timer0/1 are general purpose timer/counters. Timer0/1 has the following functionality:

- Configurable edge or level detection interrupts
- Timer or counter operation
- 4 timer/counter modes
- Baud rate generation for Debug UART

Timer0/1 comprises two 16-bit timer/counters: Timer0 and Timer1. Both can be configured as either a timer or an event counter.

Each of the timers can operate in one of four modes:

- Mode 0: 13-bit timer/counter
- Mode 1: 16-bit timer/counter
- Mode 2: 8-bit timer/counter with programmable preload value
- Mode 3: two individual 8-bit timer/counters (Timer0 only)

In the 'timer' function, the timer/counter is incremented every machine cycle. The count rate is 1/6 of the CPU clock frequency (CPU_CLK).

In the 'counter' function, the timer/counter is incremented in response to a 1-to-0 transition on the input pins P34 / SIC_CLK (Timer0) or P35 (Timer1). In this mode, the external input is sampled during state S5 of every machine cycle. If the associated pin is at logic 1 for a machine cycle, followed by logic 0 on the next machine cycle, the count is incremented. The new count value appears in the timer/counter in state S3 of the machine cycle following the one in which the transition was detected. The maximum count rate is 1/12 of the CPU_CLK frequency. There are no restrictions on the duty cycle of the external input signal but to ensure that a given level is sampled at least once before it changes, it should be held for at least one full machine cycle.

The overflow output 't1_ovf' of Timer1 can be used as a baud rate generator for the Debug UART. The Timer1 interrupt should be disabled in this case. For most applications which drive the Debug UART, Timer1 is configured for 'timer' operation and in auto-reload mode.

8.1.6.1 Timer0/1 registers

The Timer0/1 module contains six Special Function Registers (SFRs) which can be accessed by the CPU.

Table 20. Timer0/1 Special Function registers list

Name	Size [bytes]	Address Offset	Description	Access
T01CON	1	88h	Timer0/1 control register	R/W
T01MOD	1	89h	Timer0/1 mode register	R/W
T0L	1	8Ah	Timer0 timer/counter lower byte	R/W
T1L	1	8Bh	Timer1 timer/counter lower byte	R/W
T0H	1	8Ch	Timer0 timer/counter upper byte	R/W
T1H	1	8Dh	Timer1 timer/counter upper byte	R/W

The firmware performs a register read in state S5 and a register write in state S6. The hardware loads bits TF0 and TF1 of the register T01CON during state S2 and state S4 respectively. The hardware loads bits IE0 and IE1 of the register T01CON during state S1 and reset these bits during state S2. The registers T0L, T0H, T1L, T1H are updated by the hardware during states S1, S2, S3 and S4 respectively. At the end of a machine cycle, the firmware load has overridden the hardware load as the firmware writes in state S6.

Table 21. Timer0/1 SFR registers CPU state access

CPU STATE							
Register	Bit	S1	S2	S3	S4	S5	S6
T01CON	TF0		HW read			SW read	SW write
	TF1				HW read	SW read	SW write
	IE0 / IE1	HW write	HW reset			SW read	SW write
T0L		HW write				SW read	SW write
T0H			HW write			SW read	SW write
T1L				HW write		SW read	SW write
T1H					HW write	SW read	SW write

8.1.6.2 T01CON register

The register is used to control Timer0/1 and report its status.

Table 22. Timer0/1 T01CON register (SFR address 88h), bit allocation

Bit	7	6	5	4	3	2	1	0
Symbol	TF1	TR1	TF0	TR0	IE1	IT1	IE0	IT0
Reset	0	0	0	0	0	0	0	0
Access	R/W	R/W	R/W	R/W	R/W	R/W	R/W	R/W

Table 23. Description of Timer0/1 T01CON register bits

Bit	Symbol	Description
7	TF1	Timer1 overflow. Set to logic 1 by hardware on a Timer1 overflow. The flag is set to logic 0 by the CPU after 2 machine cycles. The bit IE0_3 of register IE0 (see Table 11 on page 17) has to be set to logic 1 to enable the corresponding CPU interrupt.
6	TR1	Timer1 run control. Set by firmware only. When set to logic 1, Timer1 is enabled.
5	TF0	Timer0 overflow. Set by hardware on a Timer0 overflow. The flag is set to logic 0 by the CPU after 2 machine cycles. The bit IE0_1 of register IE0 (see Table 11 on page 17) has to be set to logic 1 to enable the corresponding CPU interrupt.
4	TR0	Timer0 run control. Set by firmware only. When set to logic 1, Timer0 is enabled.
3	IE1	External Interrupt1 event. Set to logic 1 by hardware when an external interrupt is detected on P33_INT1. The bit IE0_2 of register IE0 (see Table 11 on page 17) has to be set to logic 1 to enable the corresponding CPU interrupt.
2	IT1	External Interrupt1 control. Set by firmware only. When set to logic 1, Interrupt1 triggers on a falling edge of P33_INT1. When set to logic 0, Interrupt1 triggers on a low level of P33_INT1.
1	IE0	External Interrupt0 event. Set to logic 1 by hardware when an external interrupt is detected on P32_INT0. The bit IE0_0 of register IE0 (see Table 11 on page 17) has to be set to logic 1 to enable the corresponding CPU interrupt.
0	IT0	External Interrupt0 control. Set by firmware only. When set to logic 1, Interrupt0 triggered by a falling edge on P32_INT0. When set to logic 0, Interrupt0 triggered by a low level on P32_INT0.

8.1.6.3 T01MOD register

This register is used to configure Timer0/1.

Table 24. Timer 0/1 T01MOD register (SFR address 89h), bit allocation

Bit	7	6	5	4	3	2	1	0
Symbol	GATE1	C/T1	M11	M10	GATE0	C/T0	M01	M00
Reset	0	0	0	0	0	0	0	0
Access	R/W	R/W	R/W	R/W	R/W	R/W	R/W	R/W

Table 25. Description of T01MOD bits

Bit	Symbol	Description
7	GATE1	Timer1 gate control. Set by firmware only. When set to logic 1, Timer1 is enabled only when P33_INT1 is high and bit TR1 of register T01CON is set. When set to logic 0, Timer1 is enabled.
6	C/T1	Timer1 timer/counter selector. Set by firmware only. When set to logic 1, Timer1 is set to counter operation. When set to logic 0, Timer1 is set to timer operation.
5 to 4	M[11:10]	Timer1 mode. Set by firmware only. <ul style="list-style-type: none"> • Mode 0: M11 = 0 and M10 = 0 <ul style="list-style-type: none"> – 8192 counter – T1L serves as a 5-bit prescaler • Mode 1: M11 = 0 and M10 = 1 <ul style="list-style-type: none"> – 16-bit timer/counter – T1H and T1L are cascaded • Mode 2: M11 = 1 and M10 = 0 <ul style="list-style-type: none"> – 8-bit auto-reload timer/counter. – T1H stores value to be reloaded into T1L each time T1L overflows. • Mode 3: M11 = 1 and M10 = 1 <ul style="list-style-type: none"> – Timer1 is stopped (count frozen).

Table 25. Description of T01MOD bits ...continued

Bit	Symbol	Description
3	GATE0	Timer0 gate control. Set by firmware only. When set to logic 1, Timer0 is enabled only when P32_INT0 is high and bit TR0 of register T01CON is set. When set to logic 0, Timer0 is enabled.
2	C/T0	Timer0 timer/counter selector. Set by firmware only. When set to logic 1, Timer0 is set to counter operation. When set to logic 0, Timer0 is set to timer operation.
1 to 0	M[01:00]	Timer0 mode. Set by firmware only. <ul style="list-style-type: none"> • Mode 0: M01 = 0 and M00 = 0 <ul style="list-style-type: none"> – 8192 timer – T0L acts as a 5-bit prescaler. • Mode 1: M01 = 0 and M00 = 1 <ul style="list-style-type: none"> – 16-bit timer/counter – T0H and T0L are cascaded. • Mode 2: M01 = 1 and M00 = 0 <ul style="list-style-type: none"> – 8-bit auto-reload timer/counter – T0H stores value to be reloaded into T0L each time T0L overflows. • Mode 3: M01 = 1 and M00 = 1 <ul style="list-style-type: none"> – Timer0 split into two 8-bit timer/counters T0H and T0L – T0H is controlled by the control bit of Timer1: bit TR1 of register T01CON – T0L is controlled by standard Timer0 control: “{P32_INT0 OR (NOT GATE0)} AND bit TR0”.

8.1.6.4 T0L and T0H registers

These are the actual timer/counter bytes for Timer0: T0L is the lower byte; T0H is the upper byte.

Table 26. Timer0/1 T0L register (SFR address 8Ah), bit allocation

Bit	7	6	5	4	3	2	1	0
Symbol	T0L.7	T0L.6	T0L.5	T0L.4	T0L.3	T0L.2	T0L.1	T0L.0
Reset	0	0	0	0	0	0	0	0
Access	R/W	R/W	R/W	R/W	R/W	R/W	R/W	R/W

Table 27. Description of T0L bits

Bit	Symbol	Description
7:0	T0L.7 to T0L.0	Timer0 timer/counter lower byte

Table 28. Timer0/1 T0H register (SFR address 8Ch), bit allocation

Bit	7	6	5	4	3	2	1	0
Symbol	T0H.7	T0H.6	T0H.5	T0H.4	T0H.3	T0H.2	T0H.1	T0H.0
Reset	0	0	0	0	0	0	0	0
Access	R/W	R/W	R/W	R/W	R/W	R/W	R/W	R/W

Table 29. Description of T0H bits

Bit	Symbol	Description
7 to 0	T0H.7 to T0H.0	Timer0 timer/counter upper byte

8.1.6.5 T1L and T1H registers

These are the actual timer/counter bytes for Timer1. T1L is the lower byte, T1H is the upper byte.

Table 30. Timer0/1 T1L register (SFR address 8Bh), bit allocation

Bit	7	6	5	4	3	2	1	0
Symbol	T1L.7	T1L.6	T1L.5	T1L.4	T1L.3	T1L.2	T1L.1	T1L.0
Reset	0	0	0	0	0	0	0	0
Access	R/W	R/W	R/W	R/W	R/W	R/W	R/W	R/W

Table 31. Description of T1L bits

Bit	Symbol	Description
7 to 0	T1L.7 to T1L.0	Timer1 timer/counter lower byte

Table 32. Timer0/1 T1H register (SFR address 8Dh), bit allocation

Bit	7	6	5	4	3	2	1	0
Symbol	T1H.7	T1H.6	T1H.5	T1H.4	T1H.3	T1H.2	T1H.1	T1H.0
Reset	0	0	0	0	0	0	0	0
Access	R/W	R/W	R/W	R/W	R/W	R/W	R/W	R/W

Table 33. Description of T1H bits

Bit	Symbol	Description
7 to 0	T1H.7 to T1H.0	Timer1 timer/counter upper byte

8.1.6.6 Incrementer

The two 16-bit timer/counters are built around an 8-bit incrementer. The Timer0/1 are incremented in the CPU states S1 to S4; the overflow flags are set in CPU states S2 and S4.

- CPU state S1: TOL is incremented if Timer0 is set to:
 - timer operation
 - counter operation and when a 1-to-0 transition is detected on P34 / SIC_CLK input.
- CPU state S2: TOH is incremented if:
 - TOL overflows. The overflow flag TF0 in register T01CON is updated.
- CPU state S3: T1L is incremented if Timer1 is set to:
 - timer operation or
 - counter operation and when a 1-to-0 transition is detected on P35 input.
- CPU state S4: T1H is incremented if:
 - T1L overflows. The overflow flag TF1 in register T01CON is updated.

8.1.6.7 Overflow detection

For both the upper and lower bytes of the Timer0/1, an overflow is detected by comparing the incremented value of the most significant bit with its previous value. An overflow occurs when this bit changes from logic 1 to logic 0. An overflow event in the lower byte is clocked into a flip-flop and is used in the next state as the increment enable for the upper byte. An overflow event in the upper byte will set the corresponding overflow bit in the T01CON register to logic 1. The upper byte overflow is also clocked into a flip-flop to generate the output signals 't0_ovf' and 't1_ovf'.

The overflow flags TF0 and TF1, found in register T01CON, are loaded during states S2 and S4 respectively. The interrupt controller of the 80C51 scans all requests at state S2. Thus, an overflow of Timer0 or Timer1 is detected one machine cycle after it occurred. When the request is serviced, the interrupt routine sets the overflow flag to logic 0.

Execution of the interrupt routine starts on the fourth machine cycles following the timer overflow. When Timer0/1 receives the acknowledge from the CPU:

- the overflow flag TF0 in register T01CON is set to logic 0
- two machine cycles later, the overflow flag TF1 in register T01CON is set to logic 0

If during the same machine cycle, an overflow flag is set to logic 0 due to a CPU acknowledge and set to logic 1 due to an overflow, the set to logic 1 is the strongest.

8.1.7 Timer2 description

Timer2 supports a subset of the standard Timer2 found in the 8052 microcontroller. Timer2 can be configured into 2 functional modes via the T2CON and T2MOD registers:

- Mode1: Auto-reload up/down counting
- Mode2: Baud rate generation for Debug UART

Timer2 can operate either as a timer or as an event counter.

8.1.7.1 Timer2 registers

Timer2 contains six Special Function Registers (SFRs) which can be accessed by the CPU.

Table 34. Timer2 SFR register List

Name	Size [bytes]	SFR address	Description	Access
T2CON	1	C8h	Timer2 control register	R/W
T2MOD	1	C9h	Timer2 mode register	R/W
RCAP2L	1	CAh	Timer2 reload lower byte	R/W
RCAP2H	1	CBh	Timer2 reload upper byte	R/W
T2L	1	CCh	Timer2 timer/counter lower byte	R/W
T2H	1	CDh	Timer2 timer/counter upper byte	R/W

Timer2 registers can be written to by either hardware or firmware. If both the hardware and firmware attempt to update the registers T2H, T2L, RCAP2H or RCAP2L during the same machine cycle, the firmware write takes precedence. A firmware write occurs in state S6 of the machine cycle.

Each increment or decrement of Timer2 occurs in state S1 except when in baud rate generation mode and configured as a counter. In this mode, Timer2 increments on each clock cycle. When configured as a timer, Timer2 is incremented every machine cycle. Since a machine cycle consists of 6 clock periods, the count rate is 1/6 of the CPU clock frequency.

8.1.7.2 T2CON register

The register is used to control Timer2 and report its status.

Table 35. Timer2 T2CON register (SFR address C8h) bit allocation

Bit	7	6	5	4	3	2	1	0
Symbol	TF2	-	RCLK0	TCLK0	-	TR2	C/T2	-
Reset	0	0	0	0	0	0	0	0
Access	R	R/W	R/W	R/W	R/W	R/W	R/W	R/W

Table 36. Description of T2CON bits

Bit	Symbol	Description
7	TF2	Timer2 overflow Set to logic 1 by a Timer2 overflow. Set to logic 0 by firmware. TF2 is not set when in baud rate generation mode. The bit IE0_5 of register IE0 (see Table 11 on page 17) has to be set to logic 1 to enable the corresponding CPU interrupt.
6	-	Reserved.
5	RCLK0	Timer2 Debug UART Receive Clock selector. Set by firmware only. When set to logic 1, Debug UART uses Timer2 overflow pulses. When set to logic 0, Debug UART uses overflow pulses from another source (e.g. Timer1 in a standard configuration).
4	TCLK0	Timer2 Debug UART Transmit Clock selector. Set by firmware only. When set to logic 1, Debug UART uses Timer2 overflow pulses. When set to logic 0, Debug UART uses overflow pulses from another source (e.g. Timer1 in a standard configuration).
3	-	Reserved.
2	TR2	Timer2 Run control. Set by firmware only. When set to logic 1, Timer2 is started. When set to logic 0, Timer2 is stopped.
1	C/T2	Timer2 Counter/Timer selector. Set by firmware only. When set to logic 1, Timer2 is set to counter operation. When set to logic 0, Timer2 is set to timer operation.
0	-	Reserved. This bit must be set to logic 0 by firmware.

8.1.7.3 T2MOD register

This Special Function Register is used to configure Timer2.

Table 37. Timer2 T2MOD register (SFR address C9h) bit allocation

Bit	7	6	5	4	3	2	1	0
Symbol	-	-	-	-	-	T2RD	-	DCEN
Reset	0	0	0	0	0	0	0	0
Access	R	R	R	R	R	R	R/W	R/W

Table 38. Description of T2MOD bits

Bit	Symbol	Description
7 to 3	-	Reserved.
2	T2RD	<p>Timer2 ReaD flag. Set by hardware and firmware.</p> <p>This bit is set to logic 1 by hardware, if T2H is incremented between reading T2L and reading T2H. This bit is set to logic 0, on the trailing edge of next T2L read.</p> <p>This bit is used to indicate that the 16 bit Timer2 register is not read properly since the T2H part was incremented by hardware before it was read.</p>
1	-	Reserved
0	DCEN	<p>Timer2 Down Count ENable. Set by firmware only.</p> <p>When this bit is set, Timer2 can be configured (in auto_reload mode) as an up-counter.</p> <p>When this bit is reset, Timer2 can be configured (in auto_reload mode) as a down-counter.</p>

8.1.7.4 T2L, T2H registers

These are the actual timer/counter bytes. T2L is the lower byte, T2H the upper byte.

On the fly reading can give a wrong value since T2H can be changed after T2L is read and before T2H is read. This situation is indicated by flag T2RD in T2MOD.

These two 8-bit registers are always combined to operate as one 16-bit timer/counter.

Table 39. Timer2 T2L register (SFR address CCh) bit allocation

Bit	7	6	5	4	3	2	1	0
Symbol	T2L.7	T2L.6	T2L.5	T2L.4	T2L.3	T2L.2	T2L.1	T2L.0
Reset	0	0	0	0	0	0	0	0
Access	R/W	R/W	R/W	R/W	R/W	R/W	R/W	R/W

Table 40. Description of T2L bits

Bit	Symbol	Description
7 to 0	T2L.7 to T2L.0	Timer2 timer/counter lower byte

Table 41. Timer2 T2H register (SFR address CDh) bit allocation

Bit	7	6	5	4	3	2	1	0
Symbol	T2H.7	T2H.6	T2H.5	T2H.4	T2H.3	T2H.2	T2H.1	T2H.0
Reset	0	0	0	0	0	0	0	0
Access	R/W	R/W	R/W	R/W	R/W	R/W	R/W	R/W

Table 42. Description of T2H bits

Bit	Symbol	Description
7 to 0	T2H.7 to T2H.0	Timer2 timer/counter upper byte

8.1.7.5 RCAP2L, RCAP2H registers

These are the reload bytes. In the reload mode the T2H/T2L counters are loaded with the values found in the RCAP2H/RCAP2L registers respectively.

Table 43. Timer2 RCAP2L register (SFR address CAh) bit allocation

Bit	7	6	5	4	3	2	1	0
Symbol	R2L.7	R2L.6	R2L.5	R2L.4	R2L.3	R2L.2	R2L.1	R2L.0
Reset	0	0	0	0	0	0	0	0
Access	R/W	R/W	R/W	R/W	R/W	R/W	R/W	R/W

Table 44. Description of RCAP2L bits

Bit	Symbol	Description
7 to 0	R2L.7 to R2L.0	Timer2 lower reload byte

Table 45. Timer2 RCAP2H register (SFR address CBh) bit allocation

Bit	7	6	5	4	3	2	1	0
Symbol	R2H.7	R2H.6	R2H.5	R2H.4	R2H.3	R2H.2	R2H.1	R2H.0
Reset	0	0	0	0	0	0	0	0
Access	R/W	R/W	R/W	R/W	R/W	R/W	R/W	R/W

Table 46. Description of RCAP2H bits

Bit	Symbol	Description
7 to 0	R2H.7 to R2H.0	Timer2 upper reload byte

8.1.8 Debug UART

The Debug UART is implemented to assist debug using UART_RX and UART_TX pins.

8.1.8.1 Feature list

The Debug UART has the following characteristics:

- Full duplex serial port
- Receive buffer to allow reception of a second byte while the first byte is being read out by the CPU
- Four modes of operation which support 8-bit and 9-bit data transfer at various baud rates
- Supports multi-processor communication
- Baud rate can be controlled through Timer1 or Timer2 baud rate generator

8.1.8.2 Debug UART functional description

The serial port has a receive buffer: a second byte can be stored while the previous one is read out of the buffer by the CPU. However, if the first byte has still not been read by the time reception of the second byte is complete, one of the bytes will be lost.

The receive and transmit data registers of the serial port are both accessed by firmware via the Special Function Register S0BUF. Writing to S0BUF loads the transmit register; reading from S0BUF accesses a physically separate receive register.

The serial port can operate in 4 modes. These modes are selected by programming bits SM0 and SM1 in S0CON:

- Mode 0:
 - Serial data are received and transmitted through UART_RX. UART_TX outputs the shift clock. 8 bits are transmitted/received (LSB first)
Baud rate: fixed at 1/6 of the frequency of the CPU clock
- Mode 1:
 - 10 bits are transmitted through UART_TX or received through UART_RX: a start bit (0), 8 data bits (LSB first), and a stop bit (1)
 - Receive: The received stop bit is stored into bit RB8 of register S0CON
 - Baud rate: variable (depends on overflow of Timer1 or Timer2)
- Mode 2:
 - 11 bits are transmitted through UART_TX or received through UART_RX: start bit (0), 8 data bits (LSB first), a 9th data bit, and a stop bit (1)
 - Transmit: the 9th data bit is taken from bit TB8 of S0CON. For example, the parity bit could be loaded into TB8.
 - Receive: the 9th data bit is stored into RB8 of S0CON, while the stop bit is ignored
 - Baud rate: programmable to either 1/16 or 1/32 the frequency of the CPU clock

- Mode 3:
 - 11 bits are transmitted through UART_TX or received through UART_RX: a start bit (0), 8 data bits (LSB first), a 9th data bit, and a stop bit (1). In fact, mode 3 is the same as mode 2 in all aspects except the baud rate
 - Transmit: as mode 2, the 9th data bit is taken from TB8 of S0CON
 - Receive: as mode 2, the 9th data bit is stored into RB8 of S0CON
 - Baud rate: depends on overflows of Timer1 or Timer2

The Debug UART initiates transmission and/or reception as follows.

- Transmission is initiated, in modes 0, 1, 2, 3, by any instruction that uses S0BUF as destination
- Reception is initiated, in mode 0, if RI and REN in S0CON are set to logic 0 and 1 respectively
- Reception is initiated in modes 1, 2, 3 by the incoming start bit if REN in S0CON is set to a logic 1

The Debug UART contains 2 SFRs:

Table 47. Debug UART SFR register list

Name	Size [bytes]	SFR address	Description	Access
S0CON	1	0098h	Control and status register	R/W
S0BUF	1	0099h	Transmit and receive buffer	R/W

8.1.8.3 S0CON register

The Special Function Register S0CON is the control and status register of the Debug UART. This register contains the mode selection bits (SM2, SM1, SM0), the 9th data bit for transmit and receive (TB8 and RB8), and the serial port interrupt bits (TI and RI).

Table 48. Debug UART S0CON register (SFR: address 98h) bit allocation

Bit	7	6	5	4	3	2	1	0
Symbol	SM0	SM1	SM2	REN	TB8	RB8	TI	RI
Reset	0	0	0	0	0	0	0	0
Access	R/W	R/W	R/W	R/W	R/W	R/W	R/W	R/W

Table 49. Description of S0CON bits

Bit	Symbol	Description
7 to 6	SM (0:1)	Mode selection bit 0 and 1. Set by firmware only. The Debug UART has 4 modes (Table 50 “Debug UART modes” on page 34).
5	SM2	Multi-processor communication enable. Enables the multi-processor communication feature. Set by firmware only. In mode 2 and 3: if SM2 is set to logic 1, then RI will not be activated and RB8 and S0BUF will not be loaded if the 9th data bit received is a logic 0 if SM2 is set to logic 0, it has no influence on the activation of RI and RB8 In mode 1: if SM2 is set to logic 1, then RI will not be activated and RB8 and S0BUF will not be loaded if no valid stop bit was received if SM2 is set to logic 0, it has no influence on the activation of RI and RB8 In mode 0, SM2 has no influence
4	REN	Serial reception enable. Set by firmware only. When set to logic 1, enables reception.
3	TB8	Transmit data bit. Set by firmware only. In modes 2 and 3, the value of TB8 is transmitted as the 9th data bit In modes 0 and 1, the TB8 bit is not used

Table 49. Description of S0CON bits ...continued

Bit	Symbol	Description
2	RB8	<p>Receive data bit. Set by hardware and by firmware.^[1]</p> <p>When set to logic 1:</p> <ul style="list-style-type: none"> In modes 2 or 3, the hardware stores the 9th data bit that was received in RB8 In mode 1, the hardware stores the stop bit that was received in RB8 In mode 0, the hardware does not change RB8.
1	TI	<p>Transmit interrupt flag ^[3]. TI must be set to logic 0 by firmware.</p> <ul style="list-style-type: none"> In modes 2 or 3, when transmitting, the hardware sets to logic 1 the transmit interrupt flag TI at the end of the 9th bit time In modes 0 or 1, when transmitting, the hardware sets to logic 1 the transmit interrupt flag TI at the end of the 8th bit time.
0	RI	<p>Receive interrupt flag ^[3]. RI must be set to logic 0 by firmware.</p> <ul style="list-style-type: none"> In modes 2 or 3, when receiving, the hardware sets to logic 1 the receive interrupt flag 1 clock period after sampling the 9th data bit (if SM2=1 setting RI can be blocked, see bit description of SM2 above) In mode 1, when receiving, the hardware sets to logic 1 the receive interrupt flag 1 clock period after sampling the stop bit ^[2] In mode 0, when receiving, the hardware sets to logic 1 RI at the end of the CPU state 1 of the 9th machine cycle after the machine cycle where the data reception started by a write to S0CON.

[1] If SM2 is set to logic 1, loading RB8 can be blocked, see bit description of SM2 above.

[2] If SM2 is set to logic 1, setting RI can be blocked, see bit description of SM2 above.

[3] The bit IE0_4 of register IE0 (see [Table 13 on page 18](#)) has to be set to logic 1 to enable the corresponding CPU interrupt.

Remark: The S0CON register supports a locking mechanism to prevent firmware read-modify-write instructions to overwrite the contents while hardware is modifying the contents of the register.

Table 50. Debug UART modes

Mode	SM0	SM1	Description	Baud rate
0	0	0	Shift register	$f_{clk}/6$
1	0	1	8 bits Debug UART	Variable
2	1	0	9 bits Debug UART	$f_{clk}/64$ or $f_{clk}/32$
3	1	1	9 bits Debug UART	Variable

8.1.8.4 S0BUF register

This register is implemented twice. Writing to S0BUF writes to the transmit buffer. Reading from S0BUF reads from the receive buffer. Only hardware can read from the transmit buffer and write to the receive buffer.

Table 51. Debug UART S0BUF Register (SFR: address 99h) bit allocation

Bit	7	6	5	4	3	2	1	0
Symbol	S0BUF[7:0]							
Reset	0	0	0	0	0	0	0	0
Access	R/W	R/W	R/W	R/W	R/W	R/W	R/W	R/W

Table 52. Description of S0BUF bits

Bit	Symbol	Description
7 to 0	S0BUF[7:0]	Writing to S0BUF writes to the transmit buffer. Reading from S0BUF reads from the receive buffer.

8.1.8.5 Mode 0 baud rate

In mode 0, the baud rate is derived from the CPU states signals and thus:

Baud rate in mode 0

(1)

$$\frac{clk}{6}$$

The next table lists the baud rates in Debug UART mode 0.

Table 53. Baud rates in mode 0

Conditions	Min	Typ	Max	Unit
f _{CLK}	6.78	13.56	27.12	MHz
Baud rate	1.13	2.26	4.52	Mb/s

8.1.8.6 Mode 2 baud rate

In mode 2, the baud rate depends on the value of bit SMOD from the SFR register PCON.

Baud Rate using mode 2

(2)

$$\frac{2^{SMOD}}{32} \times f_{clk}$$

The next table lists the baud rates in Debug UART mode 2.

Table 54. Baud rates in mode 2

Conditions	Min	Typ	Max	Unit
f _{CLK}	6.78	13.56	27.12	MHz
Baud rate (SMOD=0)	212	424	847.5	kb/s
Baud rate (SMOD=1)	424	847.5	1695	kb/s

8.1.8.7 Mode 1 and 3 baud rates

In modes 1 and 3, the baud rates are determined by the rate of timer1 and timer2 overflow bits: 't1_ovf' and 't2_ovf'. The register bit TCLK0 from the register T2CON selects if 't1_ovf' or 't2_ovf' should be used as a source when transmitting. The register bit RCLK0 from the register T2CON selects if 't1_ovf' or 't2_ovf' should be used as a source when receiving. The timers interrupt should be disabled when used to define the Debug UART baud rates.

The data rate is also dependant on the value of the bit SMOD from the SFR register PCON.

If over1rate is the equivalent 't1_ovf' frequency and over2rate is the equivalent 't2_ovf' frequency then:

Baud rate in mode 1 and 3 when related to timer1 overflow (3)

$$\frac{2^{SMOD}}{32} \cdot over1rate$$

See also [Section 8.1.8.8 "Baud rates using Timer1 \(Debug UART mode 1 and 3\)"](#)

Baud rate in mode 1 and 3 when related to timer2 overflow (4)

$$\frac{1}{16} \cdot over2rate$$

See also [Section 8.1.8.9 "Baud rates using Timer2 \(Debug UART mode 1 and 3\)"](#)

The next table shows the trigger select:

Table 55. Trigger select

RCLK0	TCLK0	SMOD	receive trigger rate	transmit trigger rate
0	-	0	over1rate/32	-
0	-	1	over1rate/16	-
1	-	-	over2rate/16	-
-	0	0	-	over1rate/32
-	0	1	-	over1rate/16
-	1	-	-	over2rate/16

8.1.8.8 Baud rates using Timer1 (Debug UART mode 1 and 3)

The Timer1 interrupt should be disabled in this application. The Timer1 itself can be configured for either 'timer' or 'counter' operation, and in any of its 3 running modes. In the most typical applications, it is configured for 'timer' operation, in the auto-reload mode (Timer1 mode 2: high nibble of T01MOD = 0010b). In that case the baud rate is given by the formula:

Baud rate (5)

$$\frac{2^{SMOD}}{32} \times \frac{f_{clk}}{6 \times (256 - T1H)}$$

When rewriting this formula, the value for the Timer1 reload value T1H is calculated from the desired baud rate as follows:

Timer1 reload value T1H

(6)

$$256 - \frac{2^{SMOD} \times f_{clk}}{32 \times 6 \times Baudrate}$$

One can achieve very low baud rates with Timer1 by leaving the Timer1 interrupt enabled, and configuring the timer to run as a 16-bit timer (high nibble of T01MOD = 0001b), and using the Timer1 interrupt to do a 16-bit firmware reload. Note: the frequency f_{clk} is the internal microcontroller frequency. If there is no clock divider then $f_{clk} = f_{osc}$.

For details on programming Timer1 to function as baud rate generator for the Debug UART see [Section 8.1.6 "Timer0/1 description" on page 21](#).

The next table lists the maximum baud rates for using mode 2 of Timer1.

Table 56. Maximum baud rates using mode 2 of Timer1

Reload value	f_{CLK} divided by	SMOD	Baud rate at f_{CLK}			Unit
			6.78	13.56	27.12	
FF	96	1	70.6	141.2	282.5	kb/s

The next table shows commonly used baud rates using mode 2 of Timer1 and a CLK frequency of 27.12 MHz.

Table 57. Baud rates using mode 2 of Timer1 with $f_{CLK} = 27.12$ MHz

Reload value	f_{CLK} divided by	SMOD	Baud rate at f_{CLK}	Unit
FC	706	0	38.4	kb/s
F9	1412	0	19.2	kb/s
F1	2825	0	9.6	kb/s
E3	5650	0	4.8	kb/s
C5	11300	0	2.4	kb/s
8A	22600	0	1.2	kb/s

8.1.8.9 Baud rates using Timer2 (Debug UART mode 1 and 3)

Timer2 has a programming mode to function as baud rate generator for the Debug UART. In this mode the baud rate is given by formula:

Baud rate using Timer2

(7)

$$\frac{f_{clk}}{16 \times [65536 - (T2RCH, T2RCL)]}$$

When rewriting this formula, the value for the Timer2 reload values T2RCH/L is calculated from the desired baud rate as follows:

Reload value T2RCH/L

(8)

$$65536 - \frac{f_{clk}}{16 \times Baudrate}$$

For details on programming Timer2 to function as baud rate generator for the Debug UART (see [Section 8.1.7 “Timer2 description” on page 27](#)).

Note: the frequency f_{clk} is the internal microcontroller frequency. If there is no clock divider then $f_{clk} = f_{osc}$.

The next table lists the maximum baud rates when using Timer2.

Table 58. Maximum baud rates using Timer2

Reload value T2RCH/L	f _{CLK} divided by	Baud rate			Unit
		6.78	13.56	27.12	
FFFF	16	424	847.5	1695	kb/s

8.2 General purpose IOs configurations

This chapter describes the different configurations for the IO pads:

- P72, alternate function SCK
- P71, alternate function MISO
- P70_IRQ
- P35
- P34, alternate function SIC_CLK
- P33_INT1
- P32_INT0
- P31, alternate function UART_TX
- P30, alternate function UART_RX

Note that in Hard Power Down mode, these ports are disconnected from their supply rail.

For a given port x, there are three configuration registers:

- PxCFGA[n]
- PxCFGB[n]
- Px[n]

where x is 3 or 7 and n is the bit index.

At maximum 4 different controllable modes can be supported. These modes are defined with the following bits:

- PxCFGA[n]=0 and PxCFGB[n]=0: Open drain
- PxCFGA[n]=1 and PxCFGB[n]=0: Quasi Bidirectional (Reset mode)
- PxCFGA[n]=0 and PxCFGB[n]=1: input (High Impedance)
- PxCFGA[n]=1 and PxCFGB[n]=1: Push/pull output

Px[n] is used to write or read the port value.

Here is the list of the registers used for these GPIO configuration

Table 59. Timer0/1 Special Function registers List

Name	Size [bytes]	SFR address	Description	Access
P3CFGA	1	FCh	Port 3 configuration	R/W
P3CFGB	1	FDh	Port 3 configuration	R/W
P3	1	B0h	Port 3 value	R/W
P7CFGA	1	F4h	Port 7 configuration	R/W
P7CFGB	1	F5h	Port 7 configuration	R/W
P7	1	F7h	Port 7 value	R/W

8.2.1 Pad configurations description

8.2.1.1 Open-drain

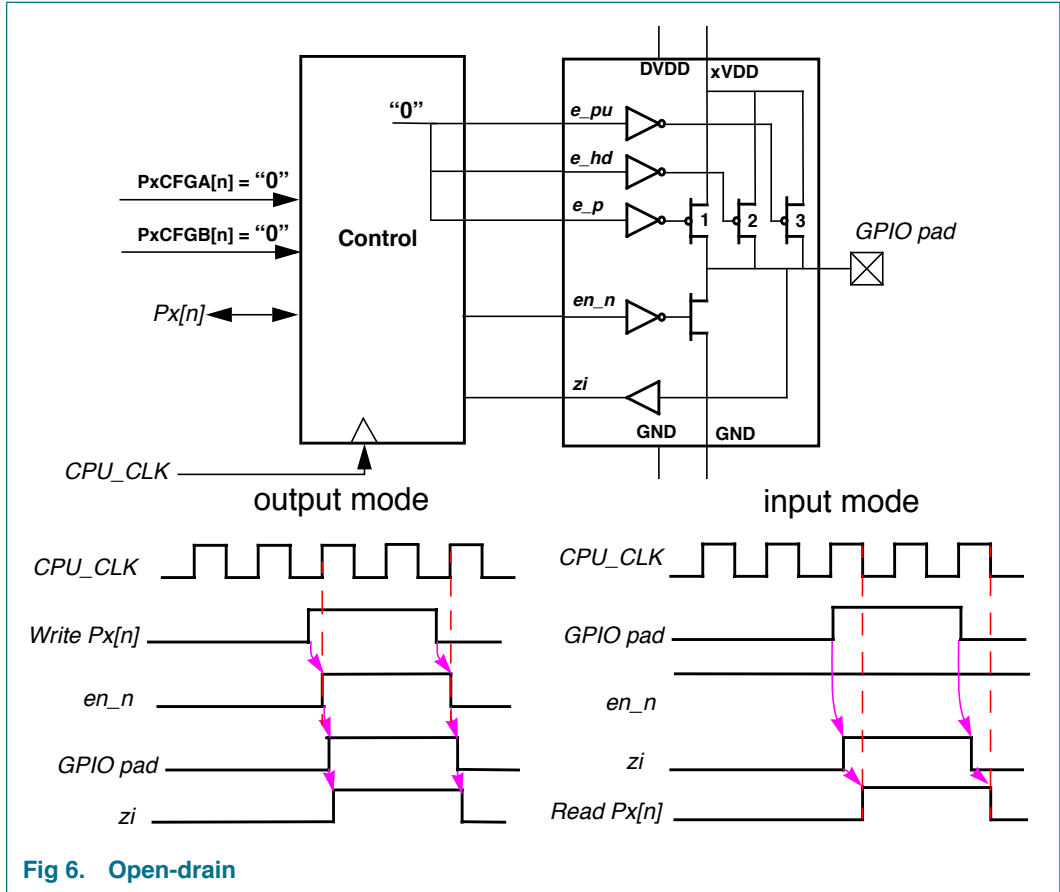

Fig 6. Open-drain

In open drain configuration, an external pull-up resistor is required to output or read a logic 1. When writing polarity $Px[n]$ to logic 0, the GPIO pad is pulled down to logic 0. When writing polarity $Px[n]$ to logic 1 the GPIO pad is in High Impedance.

8.2.1.2 Quasi Bidirectional

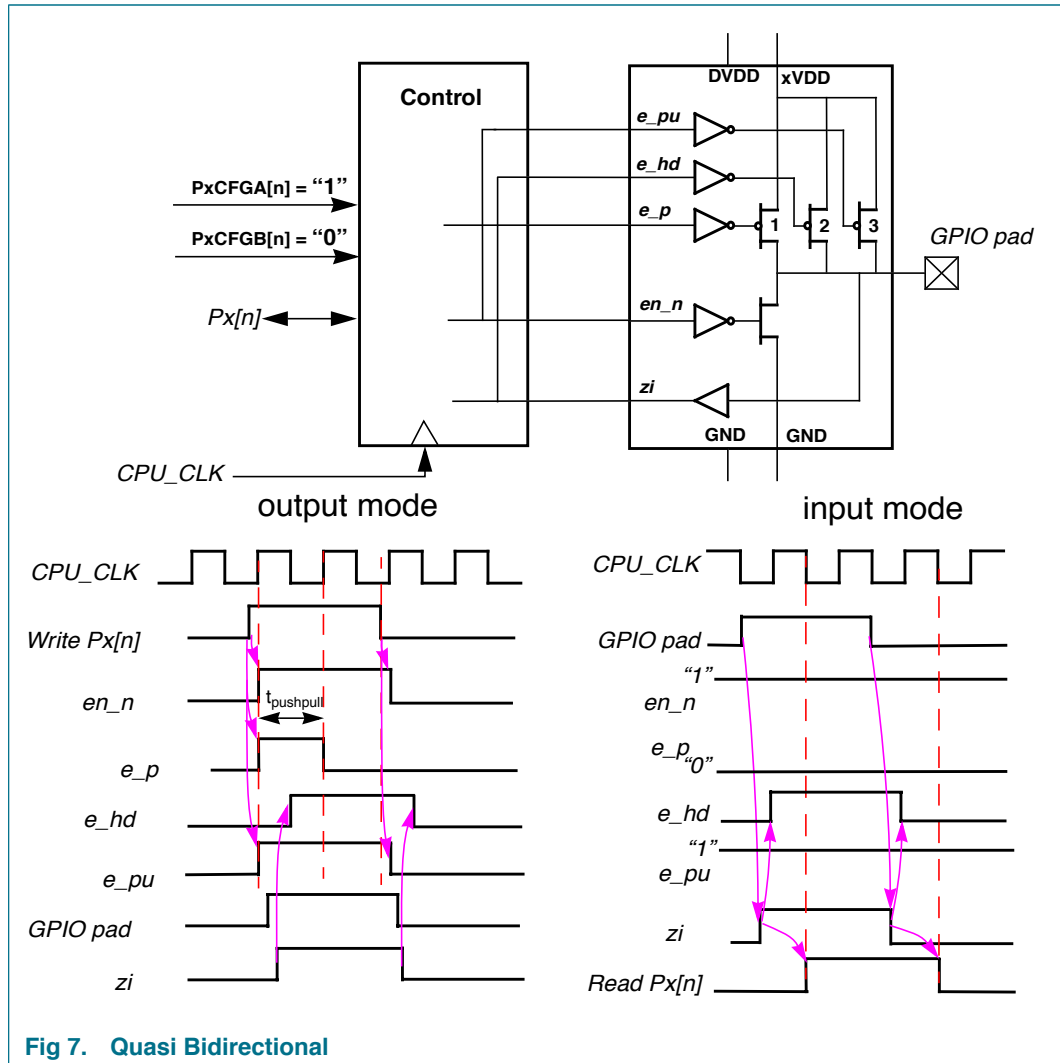

Fig 7. Quasi Bidirectional

In Quasi Bidirectional configuration, e_p is driven to logic 1 for only one CPU_CLK period when writing $Px[n]$. During the $t_{pushpull}$ time the pad drives a strong logic 1 at its output.

While zi (GPIO) is logic 1, the weak hold transistor (e_{hd}) is ON, which implements a latch function. Because of the weaker nature of this hold transistor, the pad cell can now act as an input as well.

A third very weak pull-up transistor (e_{pu}) ensures that an high impedance input is read as logic 1. e_{pu} is clocked and is at logic 1 while $Px[n]$ is at logic 1.

On a transition from logic 0 to logic 1 externally driven on GPIO pad, when the voltage on the pad is at the supply voltage divided by 2, zi goes to logic 1, the pull-up e_{hd} is ON. e_{hd} is an asynchronous signal.

The maximum currents that can be sourced by the e_{pu} transistor is 80 mA and 500 mA by e_{hd} transistor.

8.2.1.3 Input

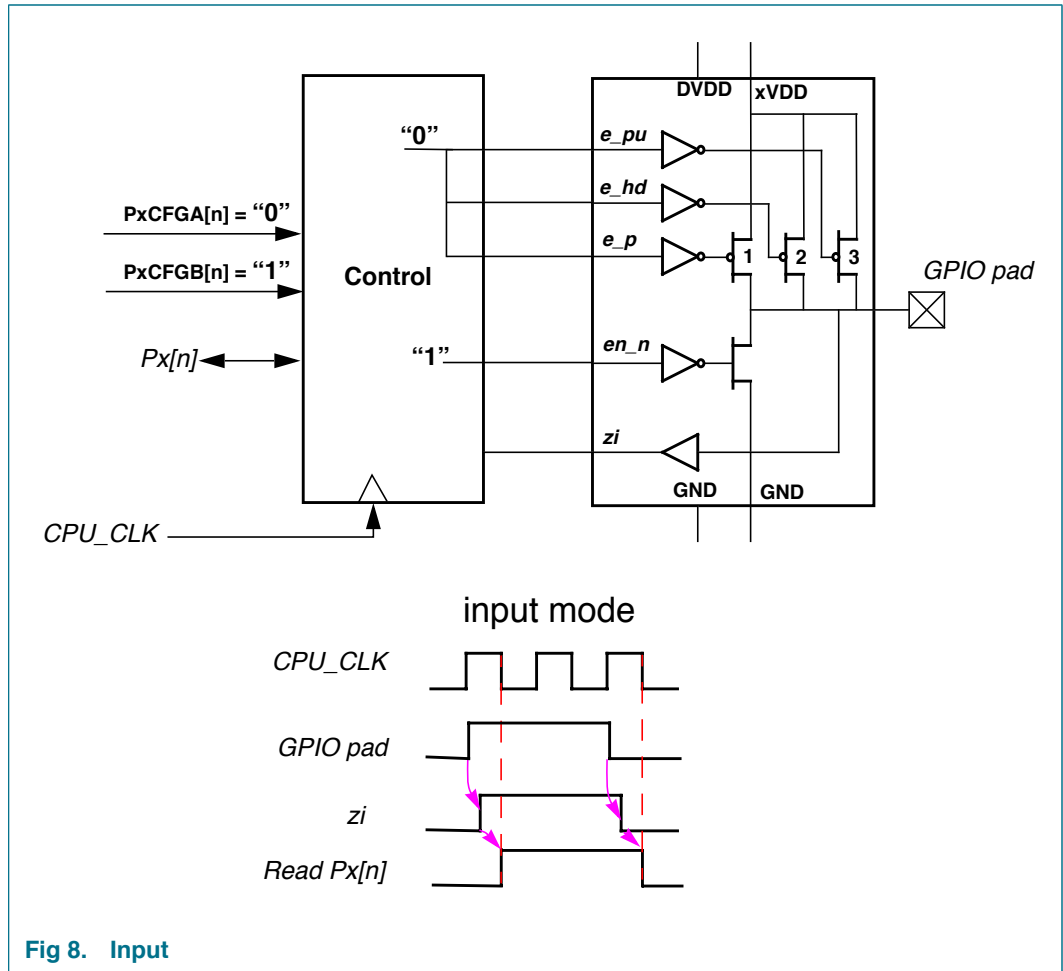

Fig 8. Input

In input configuration, no pull up or hold resistor are internally connected to the pad.

8.2.1.4 Push-pull output

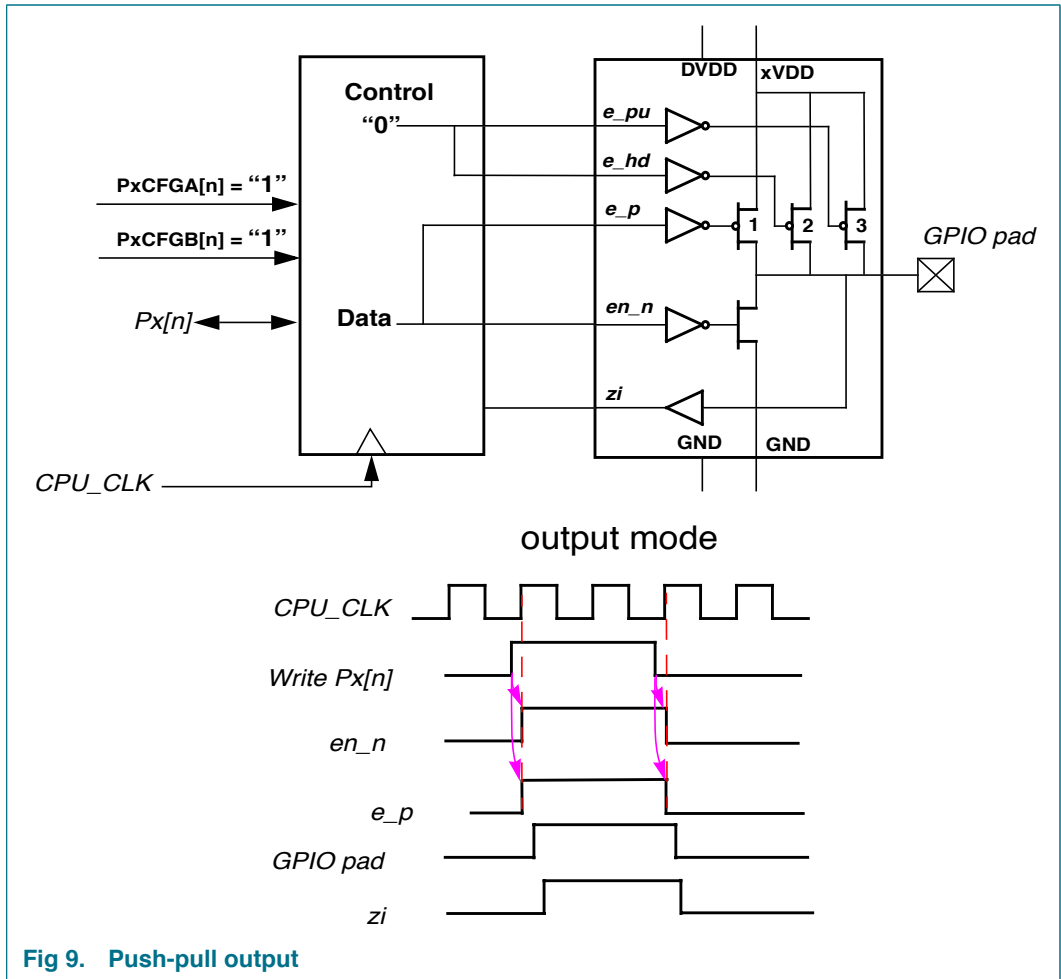

Fig 9. Push-pull output

In push-pull output, the output pin drives a strong logic 0 or a logic 1 continuously. It is possible to read back the pin output value.

8.2.2 GPIO registers description

8.2.2.1 P7CFGA register

Table 60. P7CFGA register (SFR: address F4h) bit allocation

Bit	7	6	5	4	3	2	1	0
Symbol	-	-	-	-	-	P7CFGA[2]	P7CFGA[1]	P7CFGA[0]
Reset	1	1	1	1	1	1	1	1
Access	R	R	R	R	R	R/W	R/W	R/W

Table 61. Description of P7CFGA bits

Bit	Symbol	Description
7 to 3	-	Reserved.
2	P7CFGA[2]	Out of SPI mode, and in conjunction with P7CFGB[2], it configures the functional mode of the P72 pin.
1	P7CFGA[1]	Out of SPI mode, and in conjunction with P7CFGB[1], it configures the functional mode of the P71 pin.
0	P7CFGA[0]	In conjunction with P7CFGB[0], it configures the functional mode of P70_IRQ pin.

Remark: When in Hard power down mode, the P72 to P70_IRQ pins are forced in quasi bidirectional mode. Referring to [Figure 7](#), $en_n = e_{pu} = "1"$, $e_p = "0"$. And $e_{hd} = "1"$ if P7x pin value is "1" and $e_{hd} = "0"$ if P7x pin value is "0".

8.2.2.2 P7CFGB register

Table 62. P7CFGB register (SFR: address F5h) bit allocation

Bit	7	6	5	4	3	2	1	0
Symbol	-	-	-	-	-	P7CFGB[2]	P7CFGB[1]	P7CFGB[0]
Reset	0	0	0	0	0	0	0	0
Access	R	R	R	R	R	R/W	R/W	R/W

Table 63. Description of P7CFGB bits

Bit	Symbol	Description
7 to 3	-	Reserved.
2	P7CFGB[2]	Out of SPI mode, and in conjunction with P7CFGA[2], it configures the functional mode of the P72 pin.
1	P7CFGB[1]	Out of SPI mode, and in conjunction with P7CFGA[1], it configures the functional mode of the P71 pin.
0	P7CFGB[0]	In conjunction with P7CFGA[0], it configures the functional mode of P70_IRQ pin.

Remark: When in Hard power down mode, the P72 to P70_IRQ pins are forced in quasi bidirectional mode. Referring to [Figure 7](#), $en_n = e_{pu} = "1"$, $e_p = "0"$. And $e_{hd} = "1"$ if P7x pin value is "1" and $e_{hd} = "0"$ if P7x pin value is "0".

8.2.2.3 P7 register

Table 64. P7 register (SFR: address F7h) bit allocation

Bit	7	6	5	4	3	2	1	0
Symbol	-	-	-	-	-	P7[2]	P7[1]	P7[0]
Reset	1	1	1	1	1	1	1	1
Access	R	R	R	R	R	R/W	R/W	R/W

Table 65. Description of P7 bits

Bit	Symbol	Description
7 to 3	-	Reserved.
2	P7[2]	Out of SPI mode: Writing to P7[2] writes the corresponding value to the P72 pin according to the configuration mode defined by P7CFGA[2] and P7CFGB[2]. Reading from P7[2] reads the state of P72 pin.
1	P7[1]	Out of SPI mode: Writing to P7[1] writes the corresponding value to the P71 pin according to the configuration mode defined by P7CFGA[1] and P7CFGB[1]. Reading from P7[1] reads the state of P71 pin.
0	P7[0]	Writing to P7[0] writes the corresponding value to the P70_IRQ pin according to the configuration mode defined by P7CFGA[0] and P7CFGB[0]. Reading from P7[0] reads the state of P70_IRQ pin.

8.2.2.4 P3CFGA register

Table 66. P3CFGA register (SFR: address FCh) bit allocation

Bit	7	6	5	4	3	2	1	0
Symbol	-	-	P3CFGA[5]	P3CFGA[4]	P3CFGA[3]	P3CFGA[2]	P3CFGA[1]	P3CFGA[0]
Reset	1	1	1	1	1	1	1	1
Access	R	R	R/W	R/W	R/W	R/W	R/W	R/W

Table 67. Description of P3CFGA bits

Bit	Symbol	Description
7 to 6		Reserved.
5	P3CFGA[5]	In conjunction with P3CFGB[5], it configures the functional mode of P35.
4	P3CFGA[4]	In conjunction with P3CFGB[4], it configures the functional mode of P34.
3	P3CFGA[3]	In conjunction with P3CFGB[3], it configures the functional mode of P33_INT1.
2	P3CFGA[2]	In conjunction with P3CFGB[2], it configures the functional mode of P32_INT0 ^[1]
1	P3CFGA[1]	In conjunction with P3CFGB[1], it configures the functional mode of P31
0	P3CFGA[0]	In conjunction with P3CFGB[0], it configures the functional mode of P30

[1] When CPU_PD is set to logic 1 (see [Table 7 on page 16](#)), for P32_INT0 and referring to [Section 8.2.1](#), e_hd is forced to logic 1.

Remark: When in Hard power down mode, the P35 to P30 pins are forced in quasi bidirectional mode. Referring to [Figure 7](#), en_n = e_pu = “1”, e_p = “0”. And e_hd = “1” if P3x pin value is “1” and e_hd = “0” if P3x pin value is “0”.

8.2.2.5 P3CFGB register

Table 68. P3CFGB register (SFR: address FDh) bit allocation

Bit	7	6	5	4	3	2	1	0
Symbol	-	-	P3CFGB[5]	P3CFGB[4]	P3CFGB[3]	P3CFGB[2]	P3CFGB[1]	P3CFGB[0]
Reset	0	0	0	0	0	0	0	0
Access	R	R	R/W	R/W	R/W	R/W	R/W	R/W

Table 69. Description of P3CFGB bits

Bit	Symbol	Description
7 to 6		Reserved.
5	P3CFGB[5]	In conjunction with P3CFGA[5], it configures the functional mode of P35.
4	P3CFGB[4]	In conjunction with P3CFGA[4], it configures the functional mode of P34.
3	P3CFGB[3]	In conjunction with P3CFGA[3], it configures the functional mode of P33_INT1.
2	P3CFGB[2]	In conjunction with P3CFGA[2], it configures the functional mode of P32_INT0. ^[1]
1	P3CFGB[1]	In conjunction with P3CFGA[1], it configures the functional mode of P31.
0	P3CFGB[0]	In conjunction with P3CFGA[0], it configures the functional mode of P30.

[1] When CPU_PD is set to logic 1 (see [Table 7 on page 16](#)), for P32_INT0 and referring to [Section 8.2.1](#), e_hd is forced to logic 1.

Remark: When in Hard power down mode, the P35 to P30 pins are forced in quasi bidirectional mode. Referring to [Figure 7](#), en_n = e_pu = “1”, e_p = “0”. And e_hd = “1” if P3x pin value is “1” and e_hd = “0” if P3x pin value is “0”.

8.2.2.6 P3 register

Table 70. P3 register (SFR: address B0h) bit allocation

Bit	7	6	5	4	3	2	1	0
Symbol	-	-	P3[5]	P3[4]	P3[3]	P3[2]	P3[1]	P3[0]
Reset	1	1	1	1	1	1	1	1
Access	R	R	R/W	R/W	R/W	R/W	R/W	R/W

Table 71. Description of P3 bits

Bit	Symbol	Description
7 to 6	-	Reserved.
5	P3[5]	Writing to P3[5] writes the corresponding value to P35 pin according to the configuration mode defined by P3CFGA[5] and P3CFGB[5]. Reading from P3[5] reads the state of P35 pin.
4	P3[4]	When P34 alternate function SIC_CLK is not used, writing to P3[4] writes the corresponding value to P34 pin according to the configuration mode defined by P3CFGA[4] and P3CFGB[4]. Reading from P3[4] reads the state of P34 pin.
3	P3[3]	Writing to P3[3] writes the corresponding value to P33_INT1 pin according to the configuration mode defined by P3CFGA[3] and P3CFGB[3]. Reading from P3[3] reads the state of P33_INT1 pin.
2	P3[2]	Writing to P3[2] writes the corresponding value to P32_INT0 pin according to the configuration mode defined by P3CFGA[2] and P3CFGB[2]. Reading from P3[2] reads the state of P32_INT0 pin.
1	P3[1]	When the P31 pin alternate function UART_TX is not used, writing to P3[1] writes the corresponding value to P31 pin according to the configuration mode defined by P3CFGA[1] and P3CFGB[1]. Reading from P3[1] reads the state of P31 pin.
0	P3[0]	When the P30 pin alternate function UART_RX is not used, writing to P3[0] writes the corresponding value to P30 pin according to the configuration mode defined by P3CFGA[0] and P3CFGB[0]. Reading from P3[0] reads the state of P30 pin.

8.3 Host interfaces

PN532 must be able to support different kind of interfaces to communicate with the HOST. All the interfaces that have to be supported are exclusive.

- SPI interface
- I²C interface: Standard and Fast modes
- High Speed UART (HSU): supporting specific high baud rates

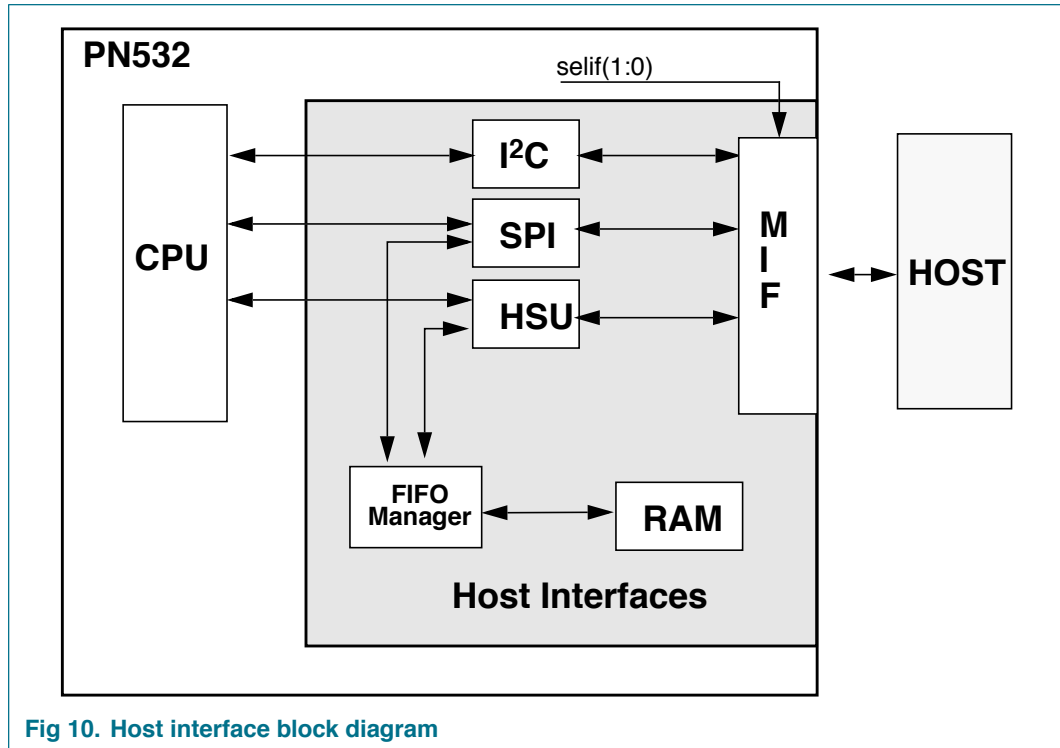

Fig 10. Host interface block diagram

8.3.1 Multi-InterFace (MIF) description

The Multi-InterFace (MIF) manages the configuration of the host interface pins, supplied by PVDD, according to the selected links with the bits selif[1:0] of register Config_I0_I1 (see [Table 74 on page 49](#)):

The firmware must copy the value of the pads I0 and I1 to respectively selif[0] and selif[1].

Table 72. HOST interface selection

Selif [1:0]	00	01	10	11
Host interface selected	HSU	SPI	I ² C	Reserved
Pin number				
27	HSU_RX	NSS	P50_SCL	-
28	HSU_TX	MOSI	SDA	-
29	P71	MISO	P71	-
30	P72	SCK	P72	-

8.3.1.1 MIF register

The Config I0_I1 register is used to select the host interface. It manages also the polarity of P33_INT1.

Table 73. Config I0_I1 register (address 6103h) bit allocation

Bit	7	6	5	4	3	2	1	0
Symbol	int1_pol	-	pad_I1	-	pad_I0	enselif	Selif[1:0]	
Reset	0	0	X	0	X	0	0	0
Access	R/W	R	R/W	R	R/W	R/W	R/W	R/W

Table 74. Description of Config I0_I1 bits

Bit	Symbol	Description
7	int1_pol	When set to logic 1, the value of the P33_INT1 pin is inverted.
6	-	Reserved.
5	pad_I1	When read this bit gives the state of the I1 pin.
4	-	Reserved.
3	pad_I0	When read this bit gives the state of the I0 pin.
2	enselif	When set to logic 1, this bit indicates that the selif bits are valid and that the selected interface on the MIF can drive the pins. The firmware must copy the value of the pads I0 and I1 to respectively selif[0] and selif[1] When set to logic 0, the MIF cannot drive the IO lines.
1:0	Selif[1:0]	These bits are used by the firmware to select the host interface communication link, see Table 72 on page 48 .

8.3.1.2 Configuration modes of the host interface pins.

In I²C mode, P50_SCL and SDA are configured in Open Drain mode.

In HSU mode, HSU_RX is in input mode and HSU_TX is in push-pull mode.

In SPI mode, NSS, MOSI and SCK are in inputs mode. MISO is in push-pull mode.

8.3.2 I²C interface

It is recommended to refer the I²C standard for more information.

The I²C interface implements a Master/Slave I²C bus interface with integrated shift register, shift timing generation and Slave address recognition. I²C Standard mode (100 kHz SCLK) and Fast mode (400 kHz SCLK) are supported.

General Call +W is supported, not hardware General Call (GC +R).

The mains characteristics of the I²C module are:

- Support Master/Slave I²C bus
- Standard and Fast mode supported
- Wake-up of the PN532 on its own address
- Wake-up on General Call +W (GC +W)

The I²C module is control through 5 registers:

Table 75. I²C register list

Name	Size [bytes]	Address	Description	Access
I ² C CON	1	D8h (SFR)	Control register	R/W
I ² C STA	1	D9h (SFR)	Status register	R/W
I ² C DAT	1	DAh (SFR)	Data register	R/W
I ² C ADR	1	DBh (SFR)	Slave Address register	R/W
i ² c_wu_control	1	610Ah	Control register for the I ² C wake-up conditions	R/W

8.3.2.1 I²C functional description

The I²C interface may operate in any of the following four modes:

- Master Transmitter
- Master Receiver
- Slave Receiver
- Slave Transmitter

Two types of data transfers are possible on the I²C bus:

- Data transfer from a Master transmitter to a Slave receiver. The first byte transmitted by the Master is the Slave address. Next follows a number of data bytes. The Slave returns an acknowledge bit after each received byte.
- Data transfer from a Slave transmitter to a Master receiver. The first byte (the Slave address) is transmitted by the Master. The Slave then returns an acknowledge bit. Next follows the data bytes transmitted by the Slave to the Master. The Master returns an acknowledge bit after each received byte except the last byte. At the end of the last received byte, a “not acknowledge” is returned.

In a given application, the I²C interface may operate as a Master or as a Slave.

In the PN532, the I²C is typically configured as a Slave, because the host is Master.

In the Slave mode, the I²C interface hardware looks for its own Slave address and the general call address. If one of these addresses is detected, an interrupt is requested. When the PN532 microcontroller wishes to become the bus Master, the hardware waits until the bus is free before the Master mode is entered so that a possible Slave action is not interrupted. If bus arbitration is lost in the Master mode, the I²C interface switches to the Slave mode immediately and can detect its own Slave address in the same serial transfer.

8.3.2.2 Master transmitter mode

As a Master, the I²C logic will generate all of the serial clock pulses and the START and STOP conditions. A transfer is ended with a STOP condition or with a repeated START condition. Since a repeated START condition is also the beginning of the next serial transfer, the I²C bus will not be released.

I²C data are output through SDA while P50_SCL outputs the serial clock. The first byte transmitted contains the Slave address of the receiving device (7-bit SLA) and the data direction bit. In this case the data direction bit (R/W) will be a logic '0' (W). I²C data are transmitted 8 bits at a time. After each byte is transmitted, an acknowledge bit is received. START and STOP conditions are output to indicate the beginning and the end of a serial transfer.

In the Master transmitter mode, a number of data bytes can be transmitted to the Slave receiver. Before the Master transmitter mode can be entered, I²CCON must be initialized with the ENS1 bit set to logic 1 and the STA, STO and SI bits set to logic 0. ENS1 must be set to logic 1 to enable the I²C interface. If the AA bit is set to logic 0, the I²C interface will not acknowledge its own Slave address or the general call address if they are present on the bus. This will prevent the I²C interface from entering a Slave mode.

The Master transmitter mode may now be entered by setting the STA bit. The I²C interface logic will then test the I²C bus and generate a start condition as soon as the bus becomes free. When a START condition is transmitted, the serial interrupt flag (SI) is set to logic 1, and the status code in the status register (I²CSTA) will be 08h. This status code must be used to vector to an interrupt service routine that loads I²CDAT with the Slave address and the data direction bit (SLA+W). The SI bit in I²CCON must then be set to logic 0 before the serial transfer can continue.

When the Slave address and the direction bit have been transmitted and an acknowledgment bit has been received, the serial interrupt flag (SI) is set to logic 1 again, and a number of status codes in I²CSTA are possible. The appropriate action to be taken for any of the status codes is detailed in [Table 80 on page 58](#). After a repeated start condition (state 10h), the I²C interface may switch to the Master receiver mode by loading I²CDAT with SLA+R.

8.3.2.3 Master receiver mode

As a Master, the I²C logic will generate all of the serial clock pulses and the START and STOP conditions. A transfer is ended with a STOP condition or with a repeated START condition. Since a repeated START condition is also the beginning of the next serial transfer, the I²C bus will not be released.

The first byte transmitted contains the Slave address of the transmitting device (7-bit SLA) and the data direction bit. In this case the data direction bit (R/W) will be logic 1 (R). I²C data are received via SDA while P50_SCL outputs the serial clock. I²C data are received 8 bits at a time. After each byte is received, an acknowledge bit is transmitted. START and STOP conditions are output to indicate the beginning and end of a serial transfer.

In the Master receiver mode, a number of data bytes are received from a Slave transmitter. The transfer is initialized as in the Master transmitter mode. When the START condition has been transmitted, the interrupt service routine must load I²CDAT with the 7-bit Slave address and the data direction bit (SLA+R). The SI bit in I²CCON must then be set to logic 0 before the serial transfer can continue.

When the Slave address and the data direction bit have been transmitted and an acknowledgment bit has been received, the serial interrupt flag (SI) is set to logic 1 again, and a number of status codes are possible in I²CSTA. The appropriate action to be taken for each of the status codes is detailed in [Table 81 on page 59](#). After a repeated start condition (state 10h), the I²C interface may switch to the Master transmitter mode by loading I²CDAT with SLA+W.

8.3.2.4 Slave receiver mode

I²C data and the serial clock are received through SDA and P50_SCL. After each byte is received, an acknowledge bit is transmitted. START and STOP conditions are recognized as the beginning and end of a serial transfer. Address recognition is performed by hardware after reception of the Slave address and direction bit.

In the Slave receiver mode, a number of data bytes are received from a Master transmitter. To initiate the Slave receiver mode, I²CADR must be loaded with the 7-bit Slave address to which the I²C interface will respond when addressed by a Master. Also the least significant bit of I²CADR should be set to logic 1 if the interface should respond to the general call address (00h). The control register, I²CCON, should be initialized with ENS1 and AA set to logic 1 and STA, STO, and SI set to logic 0 in order to enter the Slave receiver mode. Setting the AA bit will enable the logic to acknowledge its own Slave address or the general call address and ENS1 will enable the interface.

When I²CADR and I²CCON have been initialized, the I²C interface waits until it is addressed by its own Slave address followed by the data direction bit which must be '0' (W) for the I²C interface to operate in the Slave receiver mode. After its own Slave address and the W bit have been received, the serial interrupt flag (SI) is set to logic 1 and a valid status code can be read from I²CDAT. This status code should be used to vector to an interrupt service routine, and the appropriate action to be taken for each of the status codes is detailed in [Table 82 on page 60](#). The Slave receiver mode may also be entered if arbitration is lost while the I²C interface is in the Master mode.

If the AA bit is set to logic 0 during a transfer, the I²C interface will return a not acknowledge (logic 1) to SDA after the next received data byte. While AA is set to logic 0, the I²C interface does not respond to its own Slave address or a general call address. However, the I²C bus is still monitored and address recognition may be resumed at any time by setting AA. This means that the AA bit may be used to temporarily isolate the I²C interface from the I²C bus.

8.3.2.5 Slave transmitter mode

The first byte is received and handled as in the Slave receiver mode. However, in this mode, the direction bit will indicate that the transfer direction is reversed. I²C data are transmitted via SDA while the serial clock is input through P50_SCL. START and STOP conditions are recognized as the beginning and end of a serial transfer.

In the Slave transmitter mode, a number of data bytes are transmitted to a Master receiver. Data transfer is initialized as in the Slave receiver mode. When I²CADR and I²C CON have been initialized, the I²C interface waits until it is addressed by its own Slave address followed by the data direction bit which must be '1' (R) for the I²C interface to operate in the Slave transmitter mode. After its own Slave address and the R bit have been received, the serial interrupt flag (SI) is set to logic 1 and a valid status code can be read from I²CSTA. This status code is used to vector to an interrupt service routine, and the appropriate action to be taken for each of these status codes is detailed in [Table 83 on page 61](#). The Slave transmitter mode may also be entered if arbitration is lost while the I²C interface is in the Master mode.

If the AA bit is set to logic 0 during a transfer, the I²C interface will transmit the last byte of the transfer and enter state C0h or C8h. the I²C interface is switched to the not addressed Slave mode and will ignore the Master receiver if it continues the transfer. Thus the Master receiver receives all '1's as I²C data. While AA is set to logic 0, the I²C interface does not respond to its own Slave address or a general call address. However, the I²C bus is still monitored, and address recognition may be resumed at any time by setting AA. This means that the AA bit may be used to temporarily isolate the I²C interface from the I²C bus.

8.3.2.6 I²C wake-up mode

The wake up block can only be used when I²C is configured as a Slave.

It is a dedicated circuitry, separated from the main I²C peripheral which functionality is to wake-up the PN532 from Soft-Power-Down mode.

Before entering the Soft-Power-Down mode, the following actions must be taken:

- Enable the block and select the wake-up conditions (see [Table 90 on page 64](#)).
- Enable the I²C wake-up event in the PCR (see [Table 143 on page 96](#))

Once in Soft-Power-Down mode, the wake up block will monitor the I²C bus. If it recognizes its own address and the command type is valid (read only, write only, or both depending of settings in register i²c_wu_control, see [Table 90 on page 64](#)), the wake up block will generate an acknowledge, stretch P50_SCL, configure the I²C interface in Slave Transmitter or Slave Receiver mode depending on the command. Finally, i²c_on is set to logic 1, which initiates the wake-up sequence (see [Section 8.5 "Power clock and reset controller" on page 89](#)).

When the microcontroller has been woken up, the firmware must identify the wake up source and must disable the wake up block (see [Table 90 on page 64](#)) to use I²C. It is now the I²C peripheral which stretches P50_SCL.

To enable wake up on GC +W, the LSB bit of I²CADR should be set to logic 1 (see [Table 88 on page 64](#)). The wake-up block and the wake-up on a write command should be enabled before entering in Soft-Power-Down mode. When the wake up on GC +W condition is recognized, the behavior is the same as described above.

8.3.2.7 I²CCON register

The CPU can read from and write to this 8-bit SFR. Two bits are affected by the Serial IO (the I²C interface) hardware: the SI bit is set to logic 1 when a serial interrupt is requested, and the STO bit is set to logic 0 when a STOP condition is present on the I²C bus. The STO bit is also set to logic 0 when ENS1 = '0'.

Table 76. I²CCON register (SFR: address D8h) bit allocation

Bit	7	6	5	4	3	2	1	0
Symbol	CR[2]	ENS1	STA	STO	SI	AA	CR[1:0]	
Reset	0	0	0	0	0	0	0	0
Access	R/W	R/W	R/W	R/W	R/W	R/W	R/W	R/W

Table 77. Description of I²CCON bits

Bit	Symbol	Description
7	CR[2]	Serial clock frequency selection in Master mode. Together with CR[1:0], this bit determines the clock rate (serial clock frequency) when the I ² C interface is in a Master mode. Special attention has to be made on the I ² C bit frequency in case of dynamic switching of the CPU clock frequency.
6	ENS1	Serial IO enable. When ENS1 bit is to logic 0, SDA and P50_SCL are in high impedance. The state of SDA and P50_SCL is ignored, the I ² C interface is in the “not addressed” Slave state, and the STO bit in I ² CCON is forced to logic 0. No other bits are affected. When ENS1 is logic 1, the I ² C interface is enabled, assuming selif[1:0] bits are 10b (see Table 72 on page 48). ENS1 should not be used to temporarily release the I ² C interface from the I ² C bus since, when ENS1 is set to logic 0, the I ² C bus status is lost. The AA flag should be used instead.
5	STA	START control. When the STA bit is set to logic 1 to enter Master mode, the I ² C interface hardware checks the status of the I ² C bus and generates a START condition if the bus is free. If the bus is not free, then the I ² C interface waits for a STOP condition (which will free the bus) and generates a START condition after a delay of a half clock period of the internal serial clock generator. If STA is set to logic 1, while the I ² C interface is already in a Master mode and one or more bytes are transmitted or received, the I ² C interface transmits a repeated START condition. STA may be set to logic 1 at any time. This includes the case when the I ² C interface is the addressed Slave. When the STA bit is set to logic 0, no START condition or repeated START condition will be generated.

Table 77. Description of I²C CON bits ...continued

Bit	Symbol	Description
4	STO	<p>STOP control. When the STO bit is set to logic 1, while the I²C interface is in Master mode, a STOP condition is transmitted to the I²C bus. When the STOP condition is detected on the bus, the I²C interface hardware automatically sets STO to logic 0.</p> <p>In Slave mode, STO may be set to logic 1 to recover from an error condition. In this case, no STOP condition is transmitted to the I²C bus. However, the I²C interface hardware behaves as if a STOP condition has been received and switches to the defined “not addressed” Slave Receiver mode.</p> <p>If the STA and STO bits are both set to logic 1, the STOP condition is transmitted to the I²C bus if the I²C interface is in Master mode (in Slave mode, the I²C interface generates an internal STOP condition which is not transmitted). The I²C interface then transmits a START condition.</p> <p>When the STO bit is set to logic 0, no STOP condition will be generated.</p>
3	SI	<p>Serial interrupt flag. When SI is set to logic 1, then if the serial interrupt from the I²C interface port is enabled, the CPU will receive an interrupt. SI is set by hardware when any one of 25 of the possible 26 states of the I²C interface are entered. The only state that does not cause SI to be set to logic 1 is state F8h, which indicates that no relevant state information is available.</p> <p>While SI is set by hardware to logic 1, P50_SCL is held in logic 0 when the SCL line is logic 0, and P50_SCL is held in high impedance when the SCL line is logic 1.</p> <p>SI must be set to logic 0 by firmware.</p> <p>When the SI flag is set to logic 0, no serial interrupt is requested, and there is no stretching of the SCL line via P50_SCL.</p> <p>The bit IE1_4 of register IE1 (see Table 13 on page 18) has also to be set to logic 1 to enable the corresponding I²C interrupt to the CPU.</p>
2	AA	<p>Assert Acknowledge flag. If AA is set to logic 1, an acknowledge (low level to SDA) will be returned during the acknowledge clock pulse on the P50_SCL line when:</p> <ul style="list-style-type: none"> • The “own Slave address” has been received. • The general call address has been received while the general call bit (GC) in I²CADR is set. • A data byte has been received while the I²C interface is in Master Receiver mode. • A data byte has been received while the I²C interface is in the addressed Slave Receiver mode. <p>When the I²C interface is in the addressed Slave Transmitter mode, state C8h will be entered after the last serial bit is transmitted. When SI is set to logic 0, the I²C interface leaves state C8h, enters the Not-addressed Slave Receiver mode, and the SDA line remains at logic 1. In state C8h, AA can be set to logic 1 again for future address recognition.</p> <p>When the I²C interface is in the Not-addressed Slave mode, its own Slave address and the general call address are ignored. Consequently, no acknowledge is returned, and a serial interrupt is not requested. Thus, the I²C interface can be temporarily released from the I²C bus while the bus status is monitored. While the I²C interface is released from the bus, START and STOP conditions are detected, and I²C data are shifted in. Address recognition can be resumed at any time by setting AA to logic 1.</p> <p>If AA is set to logic 1 when the I²C own Slave address or the general call address has been partly received, the address will be recognized at the end of the byte transmission.</p>

Table 77. Description of I²C CON bits ...continued

Bit	Symbol	Description
1 to 0	CR[1:0]	Serial clock frequency selection in Master mode.
		CR2 CR1 CR0 CPU_CLK division factor I²C bit frequency
		0 0 0 10 CPU_CLK/10
		0 0 1 20 CPU_CLK/20
		0 1 0 30 CPU_CLK/30
		0 1 1 40 CPU_CLK/40
		1 0 0 80 CPU_CLK/80
		1 0 1 120 CPU_CLK/120
		1 1 0 160 CPU_CLK/160
		1 1 1 (256-T1 reload value)*12 24...3072 CPU_CLK/3072...CPU_CLK/24

8.3.2.8 I²CSTA register

I²CSTA is an 8-bit read-only special function register. The three least significant bits are always at logic 0. The five most significant bits contain the status code. There are 26 possible status codes. When I²CSTA contains F8h, no relevant state information is available and no serial interrupt is requested. Reset initializes I²CSTA to F8h. All other I²CSTA values correspond to defined I²C interface states. When each of these states is entered, a serial interrupt is requested (SI = '1'), this can happen in any CPU cycle, and a valid status code will be present in I²CSTA. This status code will remain present in I²CSTA until SI is set to logic 0 by firmware.

Note that I²CSTA changes one CPU_CLK clock cycle after SI changes, so the new status can be visible in the same machine cycle SI changes or possibly (in one out of six CPU states) the machine cycle after that. This should not be a problem since you should not read I²CSTA before either polling SI or entry of the interrupt handler (which in itself takes several machine cycles).

Table 78. I²CSTA register (SFR: address D9h) bit allocation

Bit	7	6	5	4	3	2	1	0
Symbol	ST[7:0]							
Reset	1	1	1	1	1	0	0	0
Access	R	R	R	R	R	R	R	R

Table 79. Description of I²CSTA bits

Bit	Symbol	Description
7 to 0	ST[7:0]	Encoded status bit for the different functional mode. Several Status codes are returned in a certain mode (Master Transmitter, Master Receiver, Slave Transmitter, Slave Receiver) plus some miscellaneous status codes that can be returned at any time.

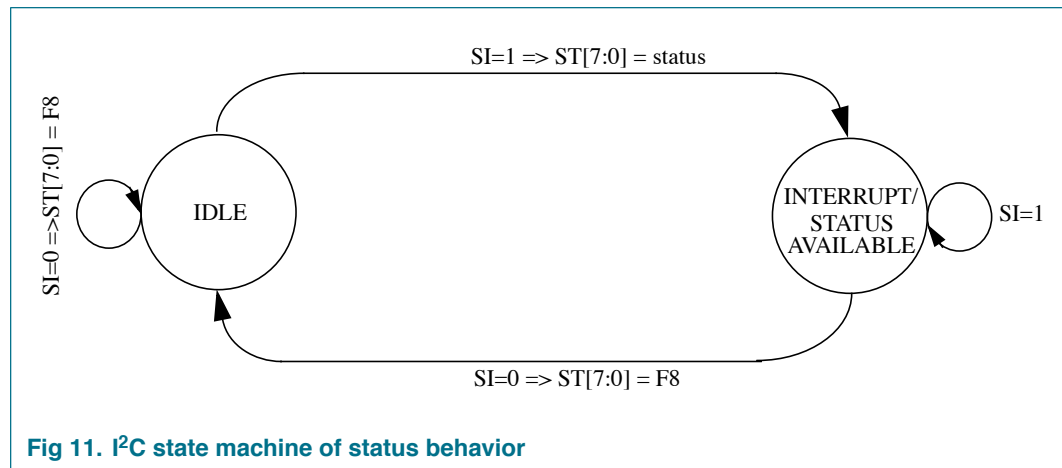

Fig 11. I²C state machine of status behavior

Table 80. I²C Master Transmitter Mode status code

Status Code ST[7:0]	Status of the I ² C Bus and of the I ² C interface Hardware	Application firmware Response					Next Action Taken By the I ² C interface Hardware
		To/from I ² CDAT	TO I ² CCON				
			STA	STO	SI	AA	
08h	A START condition has been transmitted	Load SLA+W	X	0	0	X	SLA+W will be transmitted ACK will be received
10h	A repeated START condition has been transmitted	Load SLA+W	X	0	0	X	As above
		Load SLA+R	X	0	0	X	SLA+W will be transmitted; the I ² C interface will be switched to MST/(TRX or REC) mode
18h	SLA+W has been transmitted; ACK has been received	Load data byte	0	0	0	X	Data byte will be transmitted; ACK bit will be received
		No I ² CDAT action	1	0	0	X	Repeated START will be transmitted
		No I ² CDAT action	0	1	0	X	STOP condition will be transmitted STO flag will be set to logic 0
		No I ² CDAT action	1	1	0	X	STOP condition followed by a START condition will be transmitted STO flag will be set to logic 0
20h	SLA+W has been transmitted; NOT ACK has been received	Load data byte	0	0	0	X	Data byte will be transmitted ACK bit will be received
		No I ² CDAT action	1	0	0	X	Repeated START will be transmitted
		No I ² CDAT action	0	1	0	X	STOP condition will be transmitted STO flag will be set to logic 0
		No I ² CDAT action	1	1	0	X	STOP condition followed by a START condition will be transmitted STO flag will be set to logic 0
28h	Write data byte in I ² CDAT has been transmitted; ACK has been received	Load data byte	0	0	0	X	Data byte will be transmitted; ACK bit will be received
		No I ² CDAT action	1	0	0	X	Repeated START will be transmitted
		No I ² CDAT action	0	1	0	X	STOP condition will be transmitted STO flag will be set to logic 0
		No I ² CDAT action	1	1	0	X	STOP condition followed by a START condition will be transmitted STO flag will be set to logic 0
30h	Write data byte in I ² CDAT has been transmitted; NOT ACK has been received	Load data byte	0	0	0	X	Data byte will be transmitted; ACK bit will be received
		No I ² CDAT action	1	0	0	X	Repeated START will be transmitted
		No I ² CDAT action	0	1	0	X	STOP condition will be transmitted STO flag will be set to logic 0
		No I ² CDAT action	1	1	0	X	STOP condition followed by a START condition will be transmitted STO flag will be set to logic 0
38h	Arbitration lost in SLA+R/W or Data bytes	No I ² CDAT action	0	0	0	X	I ² C bus will be released; a Slave mode will be entered
		No I ² CDAT action	1	0	0	X	A START condition will be transmitted when the bus becomes free

Table 81. I²C Master Receiver Mode status codes

Status Code ST[7:0]	Status of the I ² C Bus and the I ² C interface Hardware	Application firmware Response					Next Action Taken By the I ² C interface Hardware
		To /from I ² CDAT	TO I ² CCON				
			STA	STO	SI	AA	
08h	A START condition has been transmitted	Load SLA+W	X	0	0	X	SLA+W will be transmitted, ACK will be received
10h	A repeated START condition has been transmitted	Load SLA+W	X	0	0	X	As above
		Load SL+R	X	0	0	X	SLA+W will be transmitted; the I ² C interface will be switched to MST/(TRX or REC) mode
38h	Arbitration lost in SLA+R/W or Data bytes	No I ² CDAT action	0	0	0	X	I ² C bus will be released; a Slave mode will be entered
		No I ² CDAT action	1	0	0	X	A START condition will be transmitted when the bus becomes free
40h	SLA+R has been transmitted; ACK has been received	No I ² CDAT action	0	0	0	0	Data byte will be received; NOT ACK bit will be returned
		No I ² CDAT action	0	0	0	1	Data byte will be received; ACK bit will be returned
48h	SLA+R has been transmitted; NOT ACK has been received	No I ² CDAT action	1	0	0	X	Repeated START condition will be transmitted
		No I ² CDAT action	0	1	0	X	STOP condition will be transmitted; STO flag will be set to logic 0
		No I ² CDAT action	1	1	0	X	STOP condition followed by a START condition will be transmitted; STO flag will be set to logic 0
50h	Read data byte has been received; ACK has been returned	Read data byte or	0	0	0	0	Data byte will be received; NOT ACK bit will be returned
		Read data byte	0	0	0	1	Data byte will be received; ACK bit will be returned
58h	Read data byte has been received; NOT ACK has been returned	Read data byte	1	0	0	X	Repeated START condition will be transmitted
		Read data byte	0	1	0	X	STOP condition will be transmitted; STO flag will be set to logic 0
		Read data byte	1	1	0	X	STOP condition followed by a START condition will be transmitted; STO flag will be set to logic 0

Table 82. I²C Slave Receiver Mode status codes

Status Code ST[7:0]	Status of the I ² C Bus and the I ² C interface Hardware	Application firmware Response					Next Action Taken By the I ² C interface Hardware
		To /from I ² CDAT	TO I ² CCON				
			STA	STO	SI	AA	
60h	Own SLA+W has been received; ACK has been returned	No I ² CDAT action	X	0	0	0	Data byte will be received an NOT ACK will be returned
		No I ² CDAT action	X	0	0	1	Data byte will be received and ACK will be returned
68h	Arbitration lost in SLA+R/W as Master; Own SLA+W has been received, ACK returned	No I ² CDAT action	X	0	0	0	Data byte will be received an NOT ACK will be returned
		No I ² CDAT action	x	0	0	1	Data byte will be received and ACK will be returned
70h	General call address (00h) has been received; ACK has been returned	No I ² CDAT action	X	0	0	0	Data byte will be received and NOT ACK will be returned
		No I ² CDAT action	X	0	0	1	Data byte will be received and ACK will be returned
78h	Arbitration lost in SLA+R/W as Master; General call address has been received, ACK has been returned	No I ² CDAT action	X	0	0	0	Data byte will be received an NOT ACK will be returned
		No I ² CDAT action	X	0	0	1	Data byte will be received and ACK will be returned
80h	Previously addressed with own SLA; Write data byte has been received; ACK has been returned	Read data byte	X	0	0	0	Data byte will be received an NOT ACK will be returned
		Read data byte	X	0	0	1	Data byte will be received and ACK will be returned
88h	Previously addressed with own SLA; Write data byte has been received; NOT ACK has been returned	Read data byte	0	0	0	0	Switched to not addressed SLV mode; No recognition of own SLA or General call address
		Read data byte	0	0	0	1	Switched to not addressed SLV mode; Own SLA will be recognized; General call address will be recognized if I ² CADR[0] is set to logic 1.
		Read data byte	1	0	0	0	Switched to not addressed SLV mode; No recognition of own SLA or General call address. A START condition will be transmitted when the bus becomes free
		Read data byte	1	0	0	1	Switched to not addressed SLV mode; Own SLA will be recognized; General call address will be recognized if I ² CADR[0] is set to logic 1. A START condition will be transmitted when the bus becomes free
90h	Previously addressed with General Call; Write data byte has been received; ACK has been returned	Read data byte	X	0	0	0	Data byte will be received and NOT ACK will be returned
		Read data byte	X	0	0	1	Data byte will be received and ACK will be returned

Table 82. I²C Slave Receiver Mode status codes ...continued

Status Code ST[7:0]	Status of the I ² C Bus and the I ² C interface Hardware	Application firmware Response					Next Action Taken By the I ² C interface Hardware
		To /from I ² CDAT	TO I ² CCON				
			STA	STO	SI	AA	
98h	Previously addressed with General Call; Write data byte has been received; NOT ACK has been returned	Read data byte	0	0	0	0	Switched to not addressed SLV mode; no recognition of own SLA or General call address
		Read data byte	0	0	0	1	Switched to not addressed SLV mode; own SLA will be recognized; General call address will be recognized if I ² CADR[0] is set to logic 1.
		Read data byte	1	0	0	0	Switched to not addressed SLV mode; no recognition of own SLA or General call address. A START condition will be transmitted when the bus becomes free
		Read data byte	1	0	0	1	Switched to not addressed SLV mode; Own SLA will be recognized; General call address will be recognized if I ² CADR[0] is set to logic 1. A START condition will be transmitted when the bus becomes free
A0h	A STOP condition or repeated START condition has been received while still addressed as SLV/(REC or TRX)	Read data byte	0	0	0	0	Switched to not addressed SLV mode; no recognition of own SLA or General call address
		Read data byte	0	0	0	1	Switched to not addressed SLV mode; Own SLA will be recognized; General call address will be recognized if I ² CADR[0] is set to logic 1.
		Read data byte	1	0	0	0	Switched to not addressed SLV mode; No recognition of own SLA or General call address. A START condition will be transmitted when the bus becomes free
		Read data byte	1	0	0	1	Switched to not addressed SLV mode; Own SLA will be recognized; General call address will be recognized if I ² CADR[0] is set to logic 1. A START condition will be transmitted when the bus becomes free

Table 83. I²C Slave Transmitter Mode status codes

Status Code ST[7:0]	Status of the I ² C Bus and the I ² C interface Hardware	Application firmware Response					Next Action Taken By the I ² C interface Hardware
		To /from I ² CDAT	TO I ² CCON				
			STA	STO	SI	AA	
A8h	Own SLA+R has been received; ACK has been returned	Load data byte	X	0	0	0	Last data byte will be transmitted and ACK bit will be received
		Load data byte	X	0	0	1	Data byte will be transmitted; ACK will be received
B0h	Arbitration lost in SLA+R/W as Master; Own SLA+R has been received. ACK has been returned	Load data byte	X	0	0	0	Last data byte will be transmitted and ACK bit will be received
		Load data byte	X	0	0	1	Data byte will be transmitted; ACK will be received

Table 83. I²C Slave Transmitter Mode status codes ...continued

Status Code ST[7:0]	Status of the I ² C Bus and the I ² C interface Hardware	Application firmware Response						Next Action Taken By the I ² C interface Hardware
		To /from I ² CDAT	TO I ² CCON					
			STA	STO	SI	AA		
B8h	Read data byte in I ² CDAT has been transmitted; ACK has been received	Load data byte	X	0	0	0	Last data byte will be transmitted and ACK bit will be received	
		Load data byte	X	0	0	1	Data byte will be transmitted; ACK will be received	
C0h	Read data byte in I ² CDAT has been transmitted; NOT ACK has been received	No I ² CDAT action	0	0	0	0	Switched to not addressed SLV mode; no recognition of own SLA or General call address	
		No I ² CDAT action	0	0	0	1	Switched to not addressed SLV mode; Own SLA will be recognized; General call address will be recognized if I ² CADR[0] is set to logic 1.	
		No I ² CDAT action	1	0	0	0	Switched to not addressed SLV mode; no recognition of own SLA or General call address. A START condition will be transmitted when the bus becomes free	
		No I ² CDAT action	1	0	0	1	Switched to not addressed SLV mode; Own SLA will be recognized; General call address will be recognized if I ² CADR[0] is set to logic 1. A START condition will be transmitted when the bus becomes free	
C8h	Last read data byte in I ² CDAT has been transmitted (AA is set to logic 0); ACK has been received	No I ² CDAT action	0	0	0	0	Switched to not addressed SLV mode; no recognition of own SLA or General call address	
		No I ² CDAT action	0	0	0	1	Switched to not addressed SLV mode; Own SLA will be recognized; General call address will be recognized if I ² CADR[0] is set to logic 1.	
		No I ² CDAT action	1	0	0	0	Switched to not addressed SLV mode; no recognition of own SLA or General call address. A START condition will be transmitted when the bus becomes free	
		No I ² CDAT action	1	0	0	1	Switched to not addressed SLV mode; Own SLA will be recognized; General call address will be recognized if I ² CADR[0] is set to logic 1. A START condition will be transmitted when the bus becomes free	

Table 84. I²C Miscellaneous status codes

Status Code I ² CSTA	Status of the I ² C Bus and the I ² C interface Hardware	Application firmware Response						Next Action Taken By the I ² C interface Hardware
		To /from I ² CDAT	TO I ² CCON					
			STA	STO	SI	AA		
00h	Bus error	No I ² CDAT action	X	1	0	X	Hardware will enter the “not addressed” Slave mode	
F8h	No information available	No I ² CDAT action	--	--	--	--	--	

8.3.2.9 I²CDAT register

I²CDAT contains a byte of I²C data to be transmitted or a byte which has just been received. The CPU can read from and write to this 8-bit SFR while it is not in the process of shifting a byte. This occurs when the I²C interface is in a defined state and the serial interrupt flag SI is set to logic 1. Data in I²CDAT remains stable as long as SI is set to logic 1. The first bit to be transmitted is the MSB (bit 7), and, after a byte has been received, the first bit of received data is located at the MSB of I²CDAT. While data is being shifted out, data on the bus is simultaneously being shifted in; I²CDAT always contains the last data byte present on the bus. Thus, in the event of lost arbitration, the transition from Master Transmitter to Slave Receiver is made with the correct data in I²CDAT.

Table 85. I²CDAT register (SFR: address DAh) bit allocation

Bit	7	6	5	4	3	2	1	0
Symbol	I ² CDAT[7:0]							
Reset	0	0	0	0	0	0	0	0
Access	R/W	R/W	R/W	R/W	R/W	R/W	R/W	R/W

Table 86. Description of I²CDAT bits

Bit	Symbol	Description
7 to 0	I ² CDAT[7:0]	I²C data. Eight bits to be transmitted or just received. A logic 1 in I ² CDAT corresponds to a logic 1 on the I ² C bus, and a logic 0 corresponds to a logic 0 on the bus. I ² C data shift through I ² CDAT from right to left.

I²CDAT[7:0] and the ACK flag form a 9-bit shift register which shifts in or shifts out an 8-bit byte, followed by an acknowledge bit. The ACK flag is controlled by the I²C interface hardware and cannot be accessed by the CPU. I²C data are shifted through the ACK flag into I²CDAT on the rising edges of clock pulses on P50_SCL. When a byte has been shifted into I²CDAT, the I²C data are available in I²CDAT, and the acknowledge bit is returned by the control logic during the ninth clock pulse. I²C data are shifted out from I²CDAT via a buffer on the falling edges of clock pulses on P50_SCL.

When the CPU writes to I²CDAT, the buffer is loaded with the contents of I²CDAT[7] which is the first bit to be transmitted to the SDA line. After nine serial clock pulses, the eight bits in I²CDAT will have been transmitted to the SDA line, and the acknowledge bit will be present in ACK. Note that the eight transmitted bits are shifted back into I²CDAT.

8.3.2.10 I²CADR register

The CPU can read from and write to this 8-bit SFR. I²CADR is not affected by the I²C interface hardware. The content of this register is irrelevant when the I²C interface is in a Master mode. In the Slave modes, the seven most significant bits must be loaded with the microcontroller's own Slave address, and, if the least significant bit is set to logic 1, the general call address (00h) is recognized; otherwise it is ignored.

Table 87. I²CADR register (SFR: address DBh) bit allocation

Bit	7	6	5	4	3	2	1	0
Symbol	SA[6:0]							GC
Reset	0	0	0	0	0	0	0	0
Access	R/W	R/W	R/W	R/W	R/W	R/W	R/W	R/W

Table 88. Description of I²CADR bits

Bit	Symbol	Description
7 to 1	SA[6:0]	Slave address. These bits correspond to the 7-bit Slave address which will be recognized on the incoming data stream from the I ² C bus. When the Slave address is detected and the interface is enabled, a serial interrupt SI will be generated to the CPU.
0	GC	General call. When set to logic 1, will cause the I ² C logic to watch for the general call address to be transmitted on the I ² C bus. If a general call address is detected and this bit is set to logic 1, SI will be set to logic 1.

8.3.2.11 I²C_wu_control register

The wake up block has to be enabled before the whole chip enters in Soft-Power-Down mode. The choice of the wake-up conditions is made within the register I²C_wu_control. Read and Write conditions can be set together.

Table 89. I²C_wu_control register (address 610Ah) bit allocation

Bit	7	6	5	4	3	2	1	0
Symbol	-	-	-	-	-	i ² c_wu_en_wr	i ² c_wu_en_rd	i ² c_wu_en
Reset	0	0	0	0	0	0	0	0
Access	R	R	R	R	R	R/W	R/W	R/W

Table 90. Description of I²C_wu_control bits

Bit	Symbol	Description
7 to 3	-	Reserved.
2	i ² c_wu_en_wr	When set to logic 1, the wake-up is valid for write commands
1	i ² c_wu_en_rd	When set to logic 1, the wake-up is valid for read commands
0	i ² c_wu_en	When set to logic 1, enable the I ² C wake-up conditions. The bit i ² c_wu_en of register PCR Wakeupen (see Table 144 on page 96) has also to be set to logic 1 to enable the corresponding PN532 wake-up.

8.3.3 FIFO manager

This block is designed to manage a RAM as a FIFO in order to optimize the data exchange between the CPU and the HOST.

8.3.3.1 FIFO manager functional description

The RAM used for the FIFO is shared between the SPI and HSU interfaces. Indeed, these interfaces cannot be used simultaneously. The selection of the interface used is done by firmware. The FIFO manager block is the common part between the SPI and the HSU interfaces. It consists of a Data register, a Status register and also some registers to define the characteristics of the FIFO. These registers are addressed by the CPU as SFRs.

The RAM used as a FIFO is divided into two part: a receive part and a transmit part.

This block also manages the possible conflicts existing around the FIFO between the CPU and the interfaces. Indeed, a request coming from the interface (TR_req or RCV_req) can be simultaneous with a request to access to the data register coming from the CPU.

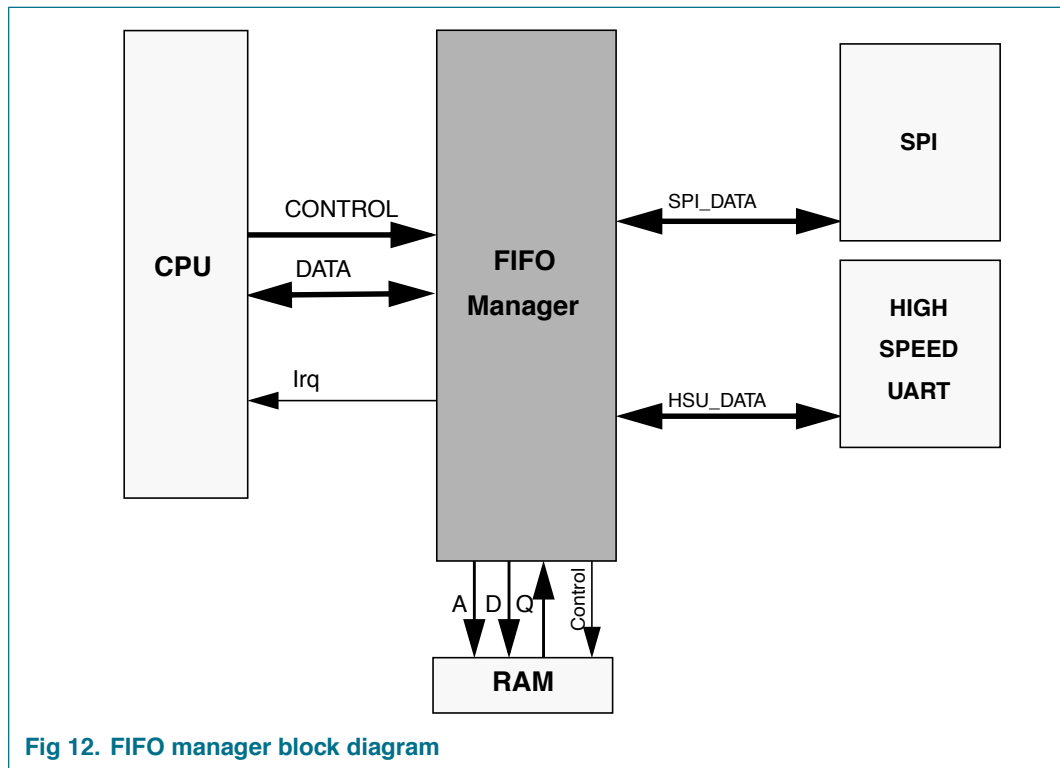

Fig 12. FIFO manager block diagram

9 SFR registers are needed to manage the FIFO manager.

Table 91. Fifo manager SFR register list

Name	Size [bytes]	SFR Address	Description	Access
RWL	1	9Ah	FIFO Receive Waterlevel: Controls the threshold of the FIFO in reception	R/W
TWL	1	9Bh	FIFO Transmit Waterlevel: Controls the threshold of the FIFO in transmission	R/W
FIFOFS	1	9Ch	FIFO Transmit FreeSpace: Status of the number of characters which can still be loaded in the FIFO	R/W
FIFOFF	1	9Dh	FIFO Receive Fullness: Status of the number of received characters in the FIFO	R/W
SFF	1	9Eh	Global Status/Error messages	R
FIT	1	9Fh	Interrupt Source	R/W
FITEN	1	A1h	Interrupt Enable and Reset FIFO	R
FDATA	1	A2h	Data reception/transmission buffer	R/W
FSIZE	1	A3h	Control the size of the FIFO in Reception	R/W

8.3.3.2 RWL register

This register defines the warning level of the Receive FIFO for the CPU. It implies a FIFO buffer overflow.

Table 92. RWL register (SFR: address 9Ah) bit allocation

Bit	7	6	5	4	3	2	1	0
Symbol	RWaterlevel[7:0]							
Reset	0	0	0	0	0	0	0	0
Access	R/W	R/W	R/W	R/W	R/W	R/W	R/W	R/W

Table 93. Description of RWL bits

Bit	Symbol	Description
7 to 0	RWaterlevel[7:0]	Overflow threshold of the Receive FIFO to set a warning

8.3.3.3 TWL register

This register defines the warning level of the Transmit FIFO for the CPU. It implies a FIFO buffer underflow.

Table 94. TWL register (SFR: address 9Bh) bit allocation

Bit	7	6	5	4	3	2	1	0
Symbol	TWaterlevel[7:0]							
Reset	0	0	0	0	0	0	0	0
Access	R/W	R/W	R/W	R/W	R/W	R/W	R/W	R/W

Table 95. Description of TWL bits

Bit	Symbol	Description
7 to 0	TWaterlevel[7:0]	Underflow threshold of the Transmit FIFO to set a warning

8.3.3.4 FIFOFS register

This register indicates the number of bytes that the CPU can still load into the FIFO until the Transmit FIFO is full.

Table 96. FIFOFS register (SFR: address 9Ch) bit allocation

Bit	7	6	5	4	3	2	1	0
Symbol	TransmitFreespace[7:0]							
Reset	0	0	0	0	0	0	0	0
Access	R/W	R/W	R/W	R/W	R/W	R/W	R/W	R/W

Table 97. Description of FIFOFS register bits

Bit	Symbol	Description
7 to 0	TransmitFreespace[7:0]	Freespace into the FIFO

8.3.3.5 FIFOFF register

This register indicates the number of bytes already received and loaded into the Receive FIFO.

Table 98. FIFOFF register (SFR: address 9Dh) bit allocation

Bit	7	6	5	4	3	2	1	0
Symbol	ReceiveFullness[7:0]							
Reset	0	0	0	0	0	0	0	0
Access	R/W	R/W	R/W	R/W	R/W	R/W	R/W	R/W

Table 99. Description of FIFOFF bits

Bit	Symbol	Description
7 to 0	ReceiveFullness[7:0]	Number of bytes received in the FIFO

8.3.3.6 SFF register

The register bits are used to allow the CPU to monitor the status of the FIFO. The primary purpose is to detect completion of data transfers.

Table 100. SFF register (SFR: address 9Eh) bit allocation

Bit	7	6	5	4	3	2	1	0
Symbol	FIFO_EN	-	TWLL	TFF	TFE	RWLH	RFF	RFE
Reset	0	0	1	0	1	0	0	1
Access	R/W	R	R	R	R	R	R	R

Table 101. Description of SFF bits

Bit	Symbol	Description
7	FIFO_EN	Fifo Enable: Set to logic 1 this bit enables the FIFO manager clock (CPU_CLK). Set to logic 0 the clock remains low.
6	-	Reserved.
5	TWLL	Transmit WaterLevelLow: This bit is set to logic 1 when the number of bytes stored into the Transmit FIFO is equal or smaller than the threshold TWaterlevel.
4	TFF	Transmit FIFO Full: This is set to logic 1 if the transmit part of the FIFO is full. It is set to logic 0 when a transfer is completed.
3	TFE	Transmit FIFO Empty: This bit indicates when the transmit part of the FIFO is empty. It is set to logic 0 when the CPU writes a character in the data register.
2	RWLH	Receive WaterLevel High: This bit is set to logic 1 when the number of bytes stored into the Receive FIFO is greater or equal to the threshold RWaterlevel.
1	RFF	Receive FIFO Full: This bit is set to logic 1 if the receive part of the FIFO is full. It is set to logic 0 by reading the FDATA register.
0	RFE	Receive FIFO Empty: This bit indicates when the receive part of the FIFO is empty. Set to logic 1, when the Receive FIFO is empty. Set to logic 0, when the Receive FIFO contains at least 1 byte.

8.3.3.7 FIT register

The FIT register contains 6 read-write bits which are logically OR-ed to generate an interrupt going to the CPU.

Table 102. FIT register (SFR: address 9Fh) bit allocation

Bit	7	6	5	4	3	2	1	0
Symbol	Reset	-	WCOL_ IRQ	TWLL_ IRQ	TFF_ IRQ	RWLH_ IRQ	ROVR_ IRQ	RFF_ IRQ
Reset	0	0	0	0	0	0	0	0
Access	W	R	R/W	R/W	R/W	R/W	R/W	R/W

Table 103. Description of FIT bits

Bit	Symbol	Description
7	Reset	Reset: Set to logic 1, Reset defines that the bits set to logic 1 in the write command are set to logic 0 in the register.
6	-	Reserved
5	WCOL_IRQ	Write COLLision IRQ: This bit is set to logic 1 when the transmitted part of the FIFO is already full (TFF is set to logic 1) and a new character is written by the CPU in the data register.
4	TWLL_IRQ	Transmit WaterLevelLow IRQ: This bit is set to logic 1 when the number of bytes stored into the Transmit FIFO is equal or smaller than the threshold TWaterlevel.
3	TFF_IRQ	Transmit FIFO Full IRQ: This is set to logic 1 if the transmitted part of the FIFO is full.
2	RWLH_IRQ	Receive WaterLevel High IRQ: This bit is set to logic 1 when the number of bytes stored into the Receive FIFO is greater or equal to the threshold RWaterlevel.
1	ROVR_IRQ	Read OVerrun IRQ: This bit indicates that a read overrun has occurred. It occurs when the receiver part of the FIFO is full and a new data transfer is completed. Then the new received data is lost and ROVR_IRQ is set.
0	RFF_IRQ	Receive FIFO Full IRQ: This bit is set to logic 1 if the received part of the FIFO is full.

8.3.3.8 FITEN register

The FITEN register enables or disables the interrupt requests to the CPU. It is also used to reset the content of the Receive and Transmit FIFO.

Table 104. FITEN register (SFR: address A1h) bit allocation

Bit	7	6	5	4	3	2	1	0
Symbol	TFLUSH	RFLUSH	EN_WCOL_IRQ	EN_TWLL_IRQ	EN_TFF_IRQ	EN_RWLH_IRQ	EN_ROVR_IRQ	EN_RFF_IRQ
Reset	0	0	0	0	0	0	0	0
Access	R/W	R/W	R/W	R/W	R/W	R/W	R/W	R/W

Table 105. Description of FITEN bits

Bit	Symbol	Description
7	TFLUSH	When set to logic level 1, the pointer of the Transmit FIFO is reset. This bit and RFLUSH must not be set at the same time.
6	RFLUSH	When set to logic level 1, the pointer of the Receive FIFO is reset. This bit and TFLUSH must not be set at the same time but one after the other.
5	EN_WCOL_IRQ	ENable Write COLlision IRQ: When set to logic 1, the WCOL_IRQ is enabled. The bit IE1_5 of register IE1 (see Table 13 on page 18) has also to be set to logic 1 to enable the corresponding CPU interrupt.
4	EN_TWLL_IRQ	ENable Transmit WaterLevelLow IRQ: When set to logic 1, the TWLL_IRQ is enabled. The bit IE1_5 of register IE1 (see Table 13 on page 18) has also to be set to logic 1 to enable the corresponding CPU interrupt.
3	EN_TFF_IRQ	ENable Transmit FIFO Full IRQ: When set to logic level 1, the TFF_IRQ is enabled. The bit IE1_5 of register IE1 (see Table 13 on page 18) has also to be set to logic 1 to enable the corresponding CPU interrupt.
2	EN_RWLH_IRQ	ENable Receive WaterLevel High IRQ: When set to logic 1, the RWLH_IRQ is enabled. The bit IE1_5 of register IE1 (see Table 13 on page 18) has also to be set to logic 1 to enable the corresponding CPU interrupt.
1	EN_ROVR_IRQ	ENable Read OVerrun IRQ: When set to logic 1, the ROVR_IRQ is enabled. The bit IE1_5 of register IE1 (see Table 13 on page 18) has also to be set to logic 1 to enable the corresponding CPU interrupt.
0	EN_RFF_IRQ	ENable Receive FIFO Full IRQ: When set to logic 1, the RFF_IRQ is enabled. The bit IE1_5 of register IE1 (see Table 13 on page 18) has also to be set to logic 1 to enable the corresponding CPU interrupt.

8.3.3.9 FDATA register

The FDATA register is used to provide the transmitted and received data bytes. Each data written in the data register is pushed into the Transmit FIFO. Each data read from the data register is popped from the Receive FIFO.

Table 106. FDATA register (SFR: address A2h) bit allocation

Bit	7	6	5	4	3	2	1	0
Symbol	FDATA[7:0]							
Reset	0	0	0	0	0	0	0	0
Access	R/W	R/W	R/W	R/W	R/W	R/W	R/W	R/W

Table 107. Description of FDATA bits

Bit	Symbol	Description
7 to 0	FDATA[7:0]	Writing to FDATA writes to the transmit buffer. Reading from FDATA reads from the receive buffer.

8.3.3.10 FSIZE register

This register defines the size of the Receive FIFO. The maximum size is 182 bytes. The free space not used by the Receive FIFO in the RAM will be allocated to Transmit FIFO.

Table 108. FSIZE register (SFR: address A3h) bit allocation

Bit	7	6	5	4	3	2	1	0
Symbol	ReceiveSize[7:0]							
Reset	0	0	0	0	0	0	0	0
Access	R/W	R/W	R/W	R/W	R/W	R/W	R/W	R/W

Table 109. Description of FSIZE bits

Bit	Symbol	Description
7 to 0	ReceiveSize[7:0]	Size of the Receive FIFO

8.3.4 HIGH SPEED UART (HSU)

The High Speed UART (HSU) provides a high speed link to the host (up to 1.288 Mbit/s).

The HSU is a full duplex serial port. The serial port has a Receive-buffer: in conjunction with the FIFO manager, the reception of several bytes can be performed without strong CPU real time constraints. However, if the Receive FIFO still has not been read by the CPU, and the number of receive bytes is greater than the Receive FIFO size then the new incoming bytes will be lost.

The HSU receive and transmit data registers are both accessed by firmware in the FIFO manager FDATA register. Writing to FDATA loads the transmit register, reading from FDATA accesses the separate receive register.

The characteristics of the UART are the following:

- Full duplex serial port
- Receive buffer to allow reception of byte while the previous bytes are stored into the FIFO manager
- 8-bit data transfers
- Programmable baud rate generator using prescaler for transmission and reception
- Based on 27.12 MHz clock frequency
- Dedicated protocol preamble filter
- Wake-up generator

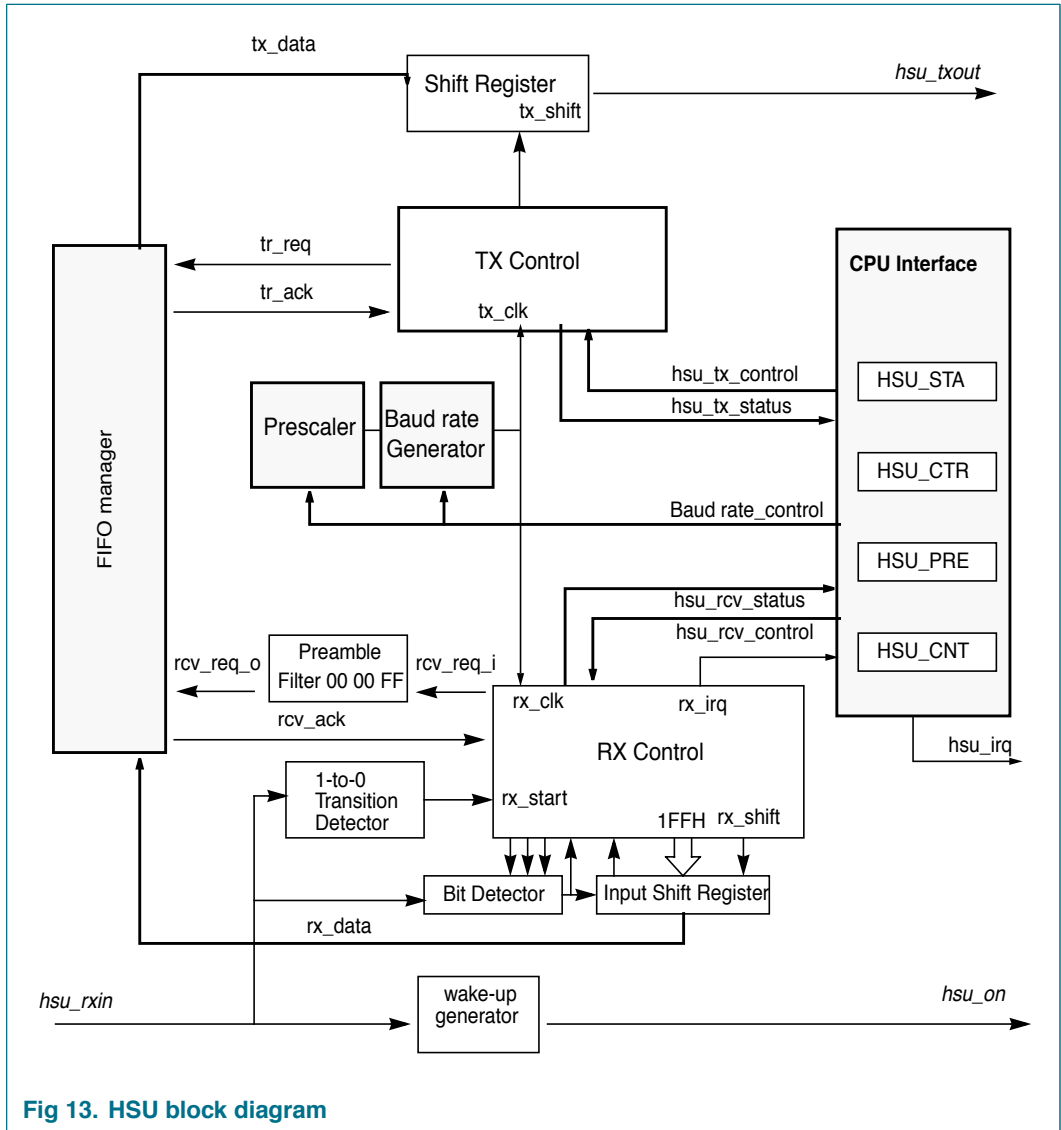

Fig 13. HSU block diagram

The HSU contains 4 SFRs:

Table 110. HSU SFR register list

Name	Size [bytes]	SFR Address	Description	Access
HSU_STA	1	ABh	HSU STAtus register	R/W
HSU_CTR	1	ACh	HSU ConTRol register	R/W
HSU_PRE	1	ADh	HSU PREscaler for baud rate generator	R/W
HSU_CNT	1	A Eh	HSU CouNter for baud rate generator	R/W

8.3.4.1 Mode of operation

The HSU supports only one operational mode, which has the following characteristics:

- Start bit:
 - Start bit is detected when a logic 0 is asserted on the HSU_RX line.
- 8 data bits:
 - The data bits are sent or received LSB first.
- Stop bit:
 - During reception, the Stop bit(s) is detected when all the data bits are received and when Stop bit(s) is sampled to logic 1. The number of Stop bits is programmable. It can be 1 or 2.
 - During Transmission, after the complete data bit transmission, a variable number of Stop bit(s) is transmitted. This number is programmable from 1 to 4.

8.3.4.2 HSU Baud rate generator

To reach the high speed transfer rate, the HSU has its own baud rate generator. The baud rate generator comprises a prescaler and a counter. The prescaler is located before the counter. The purpose of the prescaler is to divide the frequency of the count signal to enlarge the range of the counter (at the cost of a lower resolution). The division factor of the prescaler is equal to $2^{\text{HSU_PRE}[8:0]}$ ([Table 113 on page 76](#)), resulting in division factors ranging from 1 (20) to 256 (28). The combination of these 2 blocks defines the bit duration and the bit sampling.

8.3.4.3 HSU preamble filter

Received characters are sent to the FIFO manager after three consecutive characters have been received: 00 00 FF. When the frame is finished, and before a new frame arrives, firmware shall write a logic 1 in the start_frame bit of the HSU_CTR register to re-activate the preamble filter. If firmware does not write a logic 1 then all characters of the frame are sent to the FIFO manager (including the preamble).

8.3.4.4 HSU wake-up generator

The wake-up generator is a 3-bit counter which counts on every rising edge of the HSU_RX pin. When the counter reaches 5, the hsu_on signal is set to logic 1 in order to wake up the PN532. This block is useful in Soft-Power-Down mode. The firmware shall reset this counter just before going in Soft-Power-Down by writing a logic 1 in the hsu_wu_en bit into the HSU_CTR register.

8.3.4.5 HSU_STA register

The SFR HSU_STA is the status register of the HSU.

Table 111. HSU_STA register (SFR: address ABh) bit allocation

Bit	7	6	5	4	3	2	1	0
Symbol	set_bit	-	-	disable_preamb	irq_rx_over_en	irq_rx_fer_en	irq_rx_over	irq_rx_fer
Reset	0	0	0	0	0	0	0	0
Access	R/W	R	R	R/W	R/W	R/W	R/W	R/W

Table 112. Description of HSU_STA bits

Bit	Symbol	Description
7	set_bit	When set to logic 0 during write operation, the bits set to logic 1 in the write command are written to logic 0 in the register. When set to logic 1 during write operation, the bits set to logic 1 in the write command are written to logic 1 in the register.
6 to 5	-	Reserved
4	disable_preamb	Preamble filter disable. When set to logic 1, this bit disables the preamble filtering, it means that HSU_RX line transmit any received bytes to the FIFO manager.
3	irq_rx_over_en	FIFO overflow interrupt enable. When set to logic 1, this bit enables the interrupt generation when the bit irq_rx_over is set to logic 1. The bit IE1_5 of register IE1 (see Table 13 on page 18) has also to be set to logic 1 to enable the corresponding CPU interrupt.
2	irq_rx_fer_en	Framing error interrupt enable. When set to logic 1, this bit enables the interrupt generation when the bit irq_rx_fer is set to logic 1. The bit IE1_5 of register IE1 (see Table 13 on page 18) has also to be set to logic 1 to enable the corresponding CPU interrupt.
1	irq_rx_over	Receive FIFO overflow interrupt. Set to logic 1 when the FIFO manager is full (rcv_ack is set to logic 0) and when HSU shift register is ready to send another byte to the FIFO manager.
0	irq_rx_fer	Framing error interrupt. Set to logic 1 when a framing error has been detected. Framing error detection is based on Stop bit sampling. When Stop bit is expected at logic 1 but is sampled at logic 0, this bit is set to logic 1.

8.3.4.6 HSU_CTR register

This register controls the configuration of the HSU.

Table 113. HSU_CTR register (SFR: address ACh) bit allocation

Bit	7	6	5	4	3	2	1	0
Symbol	hsu_wu_en	start_frame	tx_stopbit[1:0]		rx_stopbit	tx_en	rx_en	soft_reset_n
Reset	0	0	0	0	0	0	0	1
Access	R/W	R/W	R/W	R/W	R/W	R/W	R/W	R/W

Table 114. Description of HSU_CTR bits

Bit	Symbol	Description
7	hsu_wu_en	HSU wake-up enable. When set to logic 1 this bit re-activates the NSS / SCL / HSU_RX rising-edge counter. When the counter is 5 then a signal hsu_on is activated. This signal is one of the possible wake-up events from Soft-Power-Down mode in the PCR block. The firmware shall set this bit to logic 1 just before requesting a Soft-Power-Down mode. The bit HSU_on_en of register PCR Wakeupen (see Table 144 on page 96) has also to be set to logic 1 to enable the corresponding PN532 wake-up.
6	start_frame	Enables the preamble filter for next frame. When set to logic 1 this bit indicates that a new frame is coming. This re-activates the preamble filter (when enabled), meaning that the first "00 00 FF" characters will not be sent to the FIFO manager.
5:4	tx_stopbit[1:0]	Defines the number of stop bit during transmission. These 2 bits define the number of Stop bit(s) inserted at the end of the transmitted frame. The number of Stop bit(s) transmitted is equal to tx_stopbit + 1.
3	rx_stopbit	Defines the number of stop bit during reception. This bit defines the number of Stop bit(s) inserted at the end of the received frame. The number of Stop bit(s) expected in reception is equal to rx_stopbit + 1.
2	tx_en	Enables the transmission of HSU. When set to logic 1 this bit enables the transmission of characters. When set to logic 0, the transmission is disabled only after the completion of the current transmission.
1	rx_en	Enables the reception of the HSU. When set to logic 1 this bit enables the reception of characters. When set to logic 0, the reception is disabled only after the completion of the current reception.
0	soft_reset_n	HSU Reset. When set to logic 0, this bit disables the clock of the HSU_RX control, HSU_TX control and baud rate generator modules.

8.3.4.7 HSU_PRE register

This register is used to configure the baud rate generator prescaler. The prescaler enlarges the range of the counter (at the cost of a lower resolution). The division factor of the prescaler ranges from 1 (20) to 256 (28).

Table 115. HSU_PRE register (SFR: address ADh) bit allocation

Bit	7	6	5	4	3	2	1	0
Symbol	hsu_prescaler[7:0]							
Reset	0	0	0	1	1	0	0	0
Access	R/W	R/W	R/W	R/W	R/W	R/W	R/W	R/W

Table 116. Description of HSU_PRE bits

Bit	Symbol	Description
7 to 0	hsu_prescaler[7:0]	In conjunction with HSU_CNT, defines the HSU baud rate. Baud rate = $f_{clk} / ((hsu_prescaler + 1) * hsu_counter)$

8.3.4.8 HSU_CNT register

This register is used to configure the baud rate generator counter.

Table 117. HSU_CNT register (SFR: address AEh) bit allocation

Bit	7	6	5	4	3	2	1	0
Symbol	hsu_counter[7:0]							
Reset	0	1	1	1	0	0	0	0
Access	R/W	R/W	R/W	R/W	R/W	R/W	R/W	R/W

Table 118. Description of HSU_CNT bits

Bit	Symbol	Description
7 to 0	hsu_counter[7:0]	In conjunction with HSU_PRE, defines the HSU baud rate. Baud rate = $f_{clk} / ((hsu_prescaler + 1) * hsu_counter)$

Here is a table of recommendation for some data rates:

Table 119. Recommendation for HSU data rates

Targeted data rate	HSU_CNT value	HSU_PRE value	Real HSU freq	Min recommended Host HSU freq	Max recommended Host HSU freq
9 600	0x71	0x18	9 516	9 326	9 706
19 200	0x9D	0x08	19 193	18 810	19 576
38 400	0x65	0x06	38 359	37 592	39 126
57 600	0x9D	0x02	57 579	56 428	58 730
115 200	0xEB	0x00	115 404	113 096	117 712
230 400	0x76	0x00	229 831	225 234	234 427
460 800	0x3B	0x00	459 661	450 467	468 854
921 600	0x1D	0x00	935 172	916 468	953 875
1 288 000	0x15	0x00	1 291 429	1 265 600	1 317 257

8.3.5 Serial Parallel Interface (SPI)

The SPI has the following features:

- Compliant with Motorola de-facto Serial Peripheral Interface (SPI) standard
- Synchronous, Serial, Half-Duplex communication, 5 MHz max
- Slave configuration
- 8 bits bus interface

Through the SPI interface, the host can either access the FIFO manager (acting as data buffer) or the SPI status register. This selection is made through the hereafter described protocol.

The SPI interface is managed by 2 SFRs.

Table 120. SPI SFR register list

Name	Size [bytes]	SFR address	Description	R/W
SPIcontrol	1	A9h	SPI control bits	R/W
SPIstatus	1	AAh	SPI Status/Error bits	R

8.3.5.1 Shift register pointer

A shift register is used to address the SPI interface. The value loaded in this register is either the first byte of the FIFO manager or the SPI status register.

The first byte received from the host will contain the address of the register to access (SPI status or FIFO manager FDATA) and also whether it is a SPI write or read. This character is managed by hardware.

The bits used to define these operations are the 2 LSBs of the first byte.

Table 121. SPI operation

Bit 1	Bit 0	Operation
0	0	No effect
0	1	FIFO manager write access
1	0	SPI Status register read access
1	1	FIFO manager read access

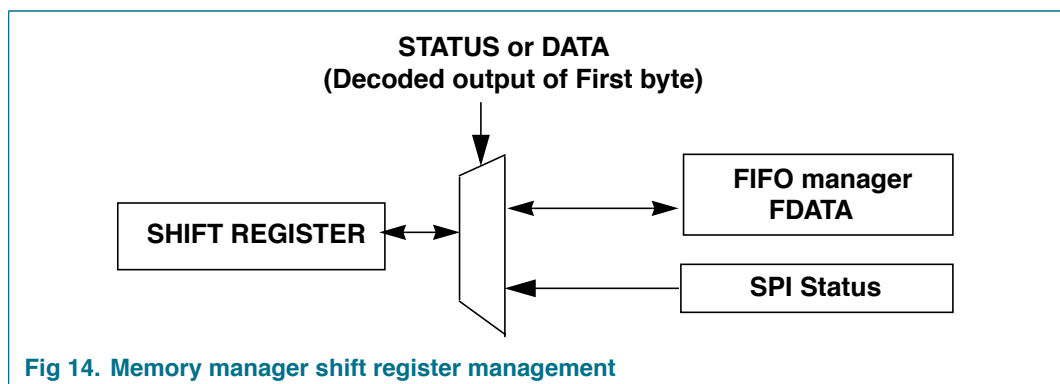

Fig 14. Memory manager shift register management

8.3.5.2 Protocol

Once the FIFO is full enough (see FIFO manager thresholds in [Table 91 on page 66](#)), the CPU sets bit READY in the SPI Status register to logic 1. Polling the SPI Status register, the host is informed of the READY flag and can start the data transfer.

The protocol used is based on:

- ADDRESS / DATA protocol for status data exchanges
- ADDRESS / DATA / DATA / DATA... for data transfers

An exchange starts on the falling edge of NSS and follows the diagram described below.

8.3.5.3 SPI status register read

There is in that case no read request going to the FIFO manager. The content of the status register is loaded in the SPI shift register.

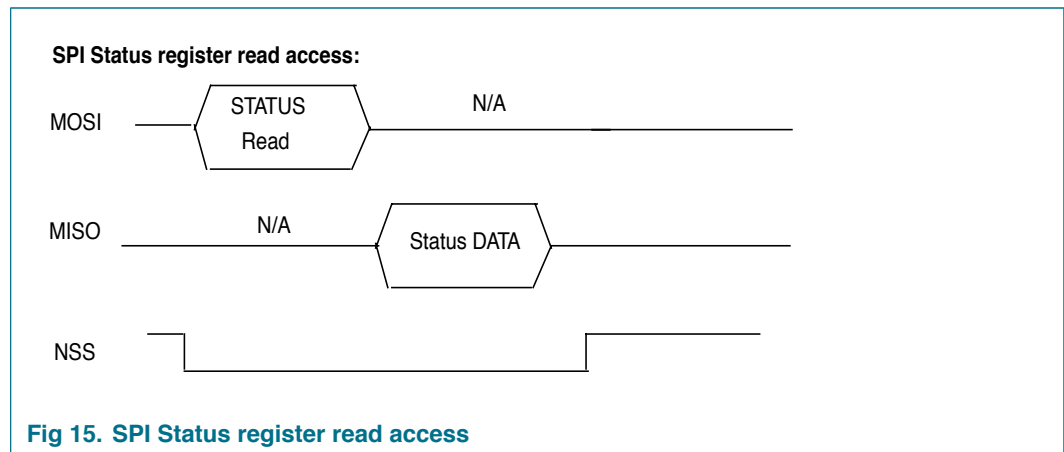

Fig 15. SPI Status register read access

8.3.5.4 FIFO manager read access

Bytes are loaded from the FIFO manager into the SPI shift register and sent back to the host.

Remark: for proper operation, the firmware should write an additional byte in the FIFO manager (FDATA). This byte will not be transmitted.

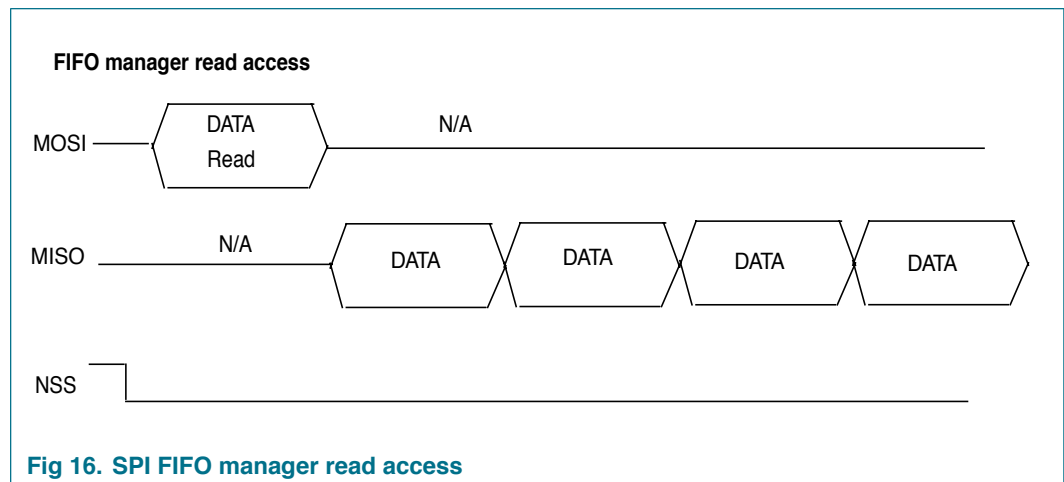

Fig 16. SPI FIFO manager read access

8.3.5.5 FIFO manager write access

MISO is maintained at logic 0. Once a byte is received, a write request is sent to the FIFO manager and the byte is loaded from SPI shift register into Receive FIFO of the FIFO manager.

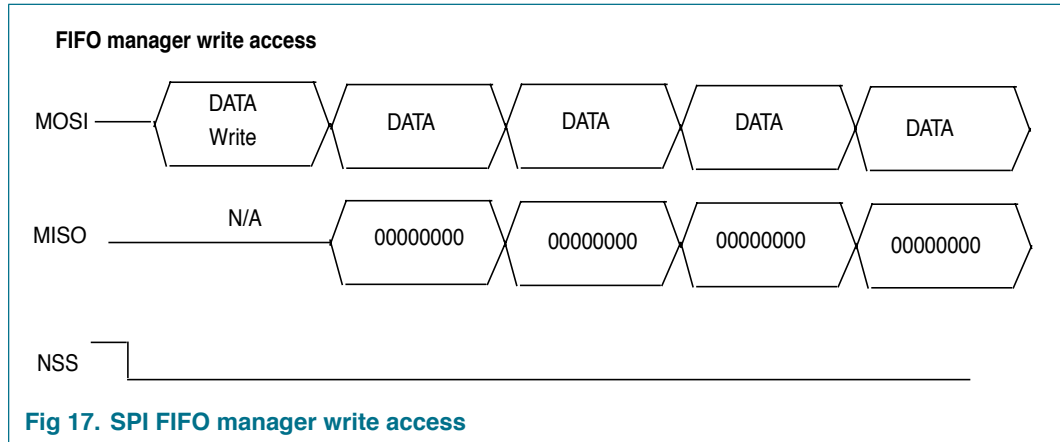

Fig 17. SPI FIFO manager write access

8.3.5.6 SPIControl register

SPIControl register contains programmable bits used to control the function of the SPI block. This register has to be set prior to any data transfer.

Table 122. SPIControl register (SFR: address A9h) bit allocation

Bit	7	6	5	4	3	2	1	0
Symbol	-	-	Enable	-	CPHA	CPOL	IE1	IE0
Reset	0	0	0	0	0	0	0	0
Access	R	R	R/W	R	R/W	R/W	R/W	R/W

Table 123. Description of SPIControl bits

Bit	Symbol	Description
7 to 6	-	Reserved.
5	Enable	SPI enable: When set to logic 1, enables the SPI interface assuming that selif[1:0] are set to 01b.
4	-	Reserved.
3	CPHA	Clock PHase: This bit controls the relationship between the data and the clock on SPI transfers. When set to logic 0: Data is always sampled on the first clock edge of SCK. When set to logic 1: Data is always sampled on the second clock edge of SCK.
2	CPOL	Clock POLarity: This bit controls the polarity of SCK clock. When set to logic 1, SCK starts from logic 0 else starts from logic 1.
1	IE1	Interrupt Enable 1: When set to logic 1, the hardware interrupt generated by TR_FE in SPIstatus register is enabled. The bit IE1_5 of register IE1 (see Table 13 on page 18) has also to be set to logic 1 to enable the corresponding CPU interrupt.
0	IE0	Interrupt Enable 0: When set to logic 1, the hardware interrupt generated by RCV_OVR in SPIstatus register is enabled. The bit IE1_5 of register IE1 (see Table 13 on page 18) has also to be set to logic 1 to enable the corresponding CPU interrupt.

Remark: The following figure explains how bits CPOL and CPHA can be used.

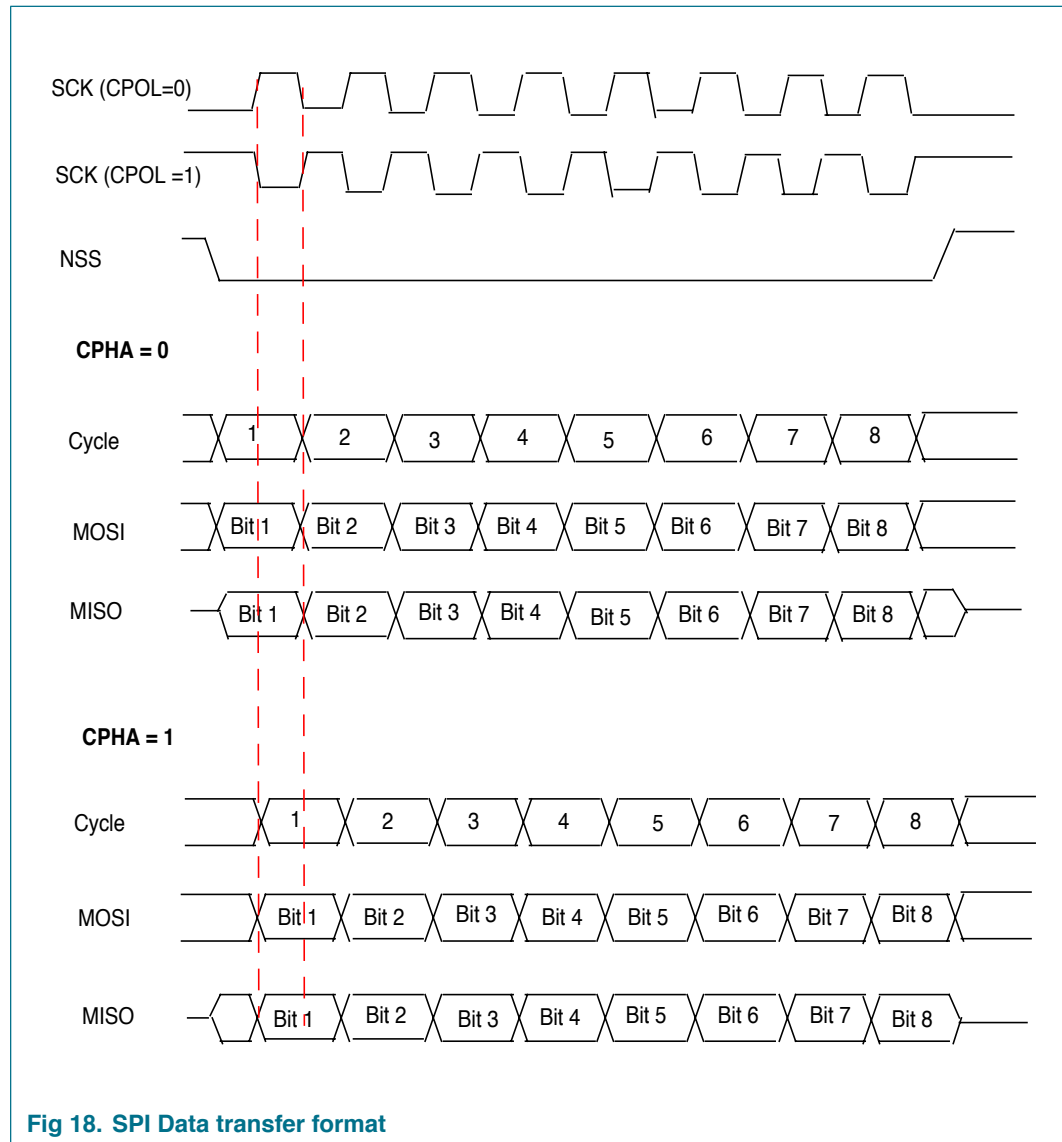

Fig 18. SPI Data transfer format

8.3.5.7 SPIstatus register

The SPIstatus register is byte addressable. It contains bits which are used to monitor the status of the SPI interface, including normal functions, and exception conditions. The primary purpose of this register is to detect completion of a data transfer. The remaining bits in this register are exception condition indicators.

Table 124. SPIstatus register (SFR: address AAh) bit allocation

Bit	7	6	5	4	3	2	1	0
Symbol	-	-	-	-	TR_FE	RCV_OVR	-	READY
Reset	0	0	0	0	0	0	0	0
Access	R	R	R	R	R/W	R/W	R/W	R/W

Table 125. Description of SPIstatus bits

Bit	Symbol	Description
7 to 4	-	Reserved.
3	TR_FE	Transmit FIFO Empty: Set to logic 1 when the host attempts to read a new byte and FIFO manager is empty. An interrupt can be generated if enabled (see IE1 bit in register SPIcontrol). It is set to logic 0 by firmware.
2	RCV_OVR	Receive Overrun: Set to logic 1 when the host attempts to write a new byte and FIFO manager is full, or has not yet processed the previous byte. An interrupt can be generated if enabled (see IE0 bit in register SPIcontrol). It is set to logic 0 by firmware.
1	-	Reserved. This bit must be set to logic 0.
0	READY	Ready flag. The firmware set READY to logic 1 to inform the host when PN532 is ready to send data.

8.4 Power management

Figure 19 “Power management scheme” depicts the internal and external power distribution management. Power is supplied to the PN532 via pins VBAT and PVDD. VBAT is driven by the battery and is used to supply the all blocks excluding the host interface. PVDD is connected to the host’s power supply and powers the PN532’s host interface. No specific sequencing is required between the two supply rails: VBAT can be present without PVDD and vice versa.

An internal low drop-out (LDO) voltage regulator generates DVDD and SVDD, which are used to supply the internal digital logic and the secure IC respectively. DVDD is also routed externally to supply AVDD (analog power) and TVDD (transmit power). DVDD, AVDD and TVDD must be separately decoupled.

When another host interface than SPI is used, the PN532 can be used with reduced functionalities; all functionalities, except those related to the PVDD supplied pins (like host interfaces) when:

- PVDD < 0.4V
- 5.5V > VBAT > 2.7V
- 3.6V > RSTPD_N > VBAT * 0.65

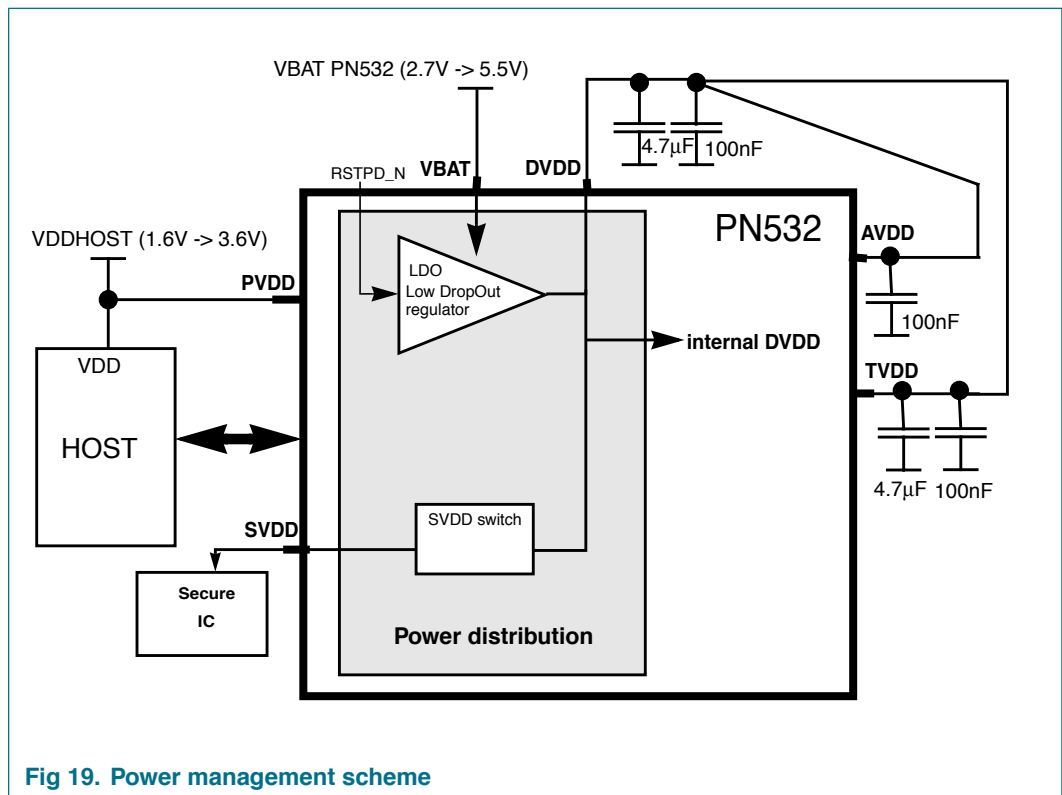

Fig 19. Power management scheme

8.4.1 Low drop-out voltage regulator

8.4.1.1 LDO block diagram

The regulator is used to reduce the VBAT voltage to the typical voltage rating of the PN532. It acts as a 3.0 V linear regulator with resistive feed-back, as long as the VBAT voltage is above 3.4 V. It is designed to cope with a maximum fluctuation of 400 mV on the VBAT line (due to voltage bursts exhibited by the battery).

If VBAT falls below 3.4 V, the output of the regulator tracks VBAT with a variable delta. It continues to reject any noise on the VBAT line via the use of an internal band-gap reference.

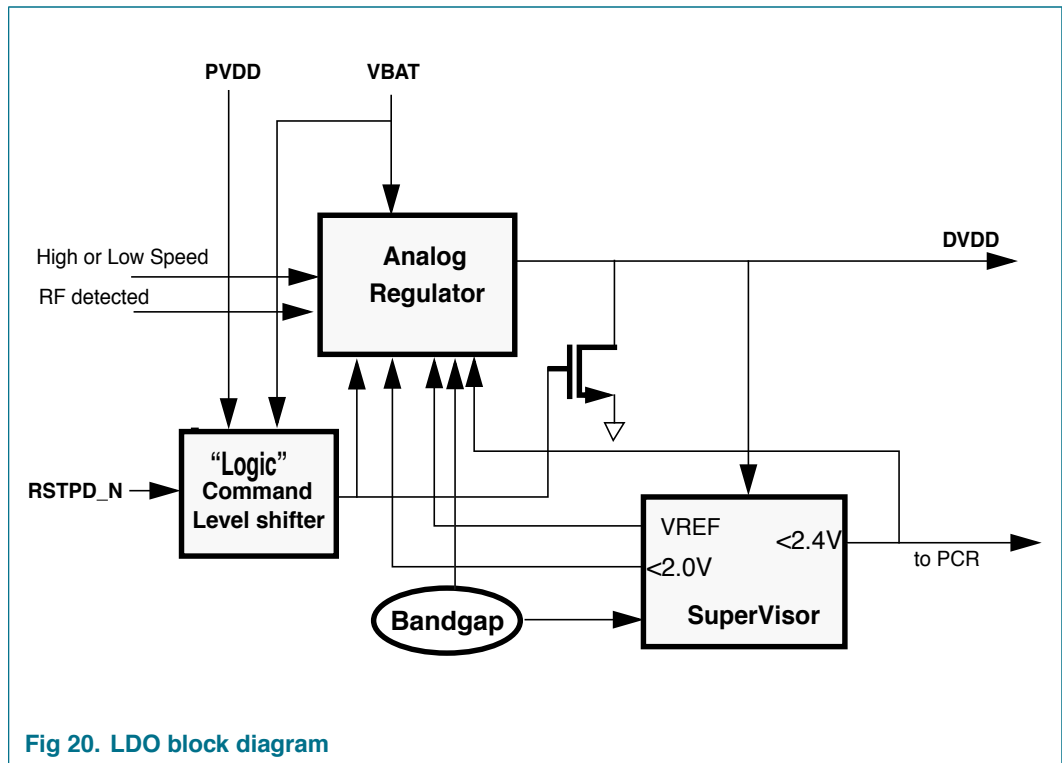

Fig 20. LDO block diagram

8.4.1.2 LDO with offset

The LDO generates DVDD. When RSTPD_N is high, and PVDD is above 1.6 V, this voltage is defined by:

- $V_{BAT} > 3.4V$: DVDD is fixed at 3V and bursts on VBAT up to 400 mV are suppressed.
- $3.4V > V_{BAT} > 2.5V$: DVDD follows VBAT with an offset, which decreases with VBAT from 400mV at 3.4V to 0mV at 2.5V.
- $2.5V > V_{BAT} > 2.35V$: DVDD=VBAT.
- $2.35V > V_{BAT}$: DVDD=VBAT and the PN532 is in reset.

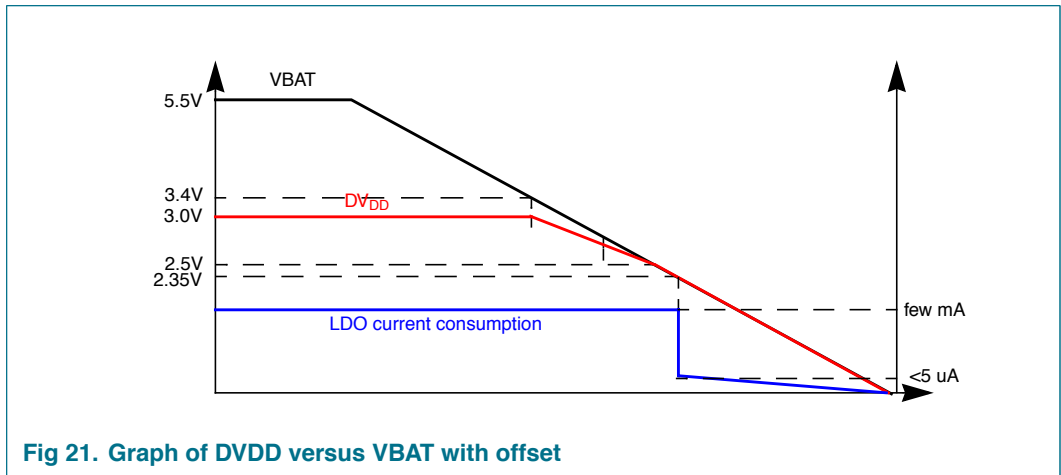

Fig 21. Graph of DVDD versus VBAT with offset

When the PN532 is in Soft-Power-Down mode, bursts rejection is no longer present and the behavior then becomes:

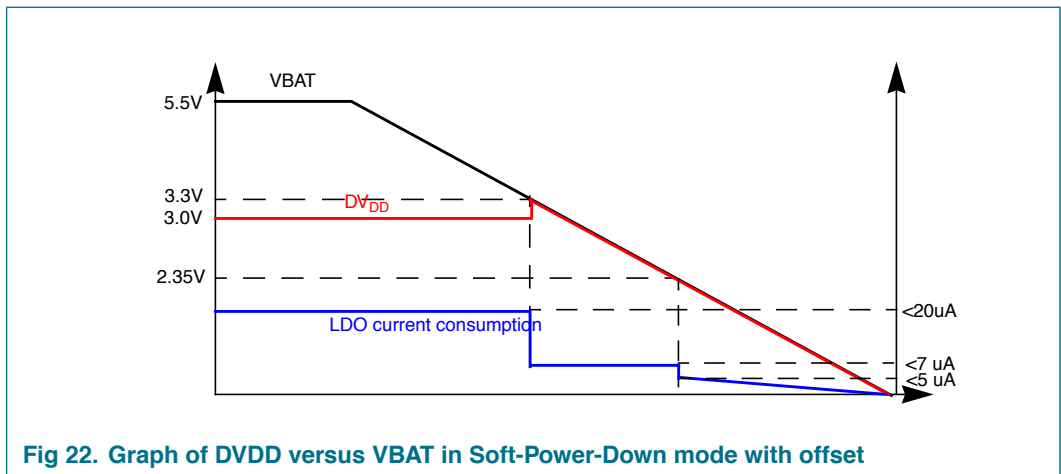

Fig 22. Graph of DVDD versus VBAT in Soft-Power-Down mode with offset

8.4.1.3 LDO without offset

The LDO generates DVDD but any voltage fluctuation on VBAT is not compensated for. When RSTPD_N is high and PVDD is above 1.6 V, this voltage is defined by:

- $V_{BAT} > 3.0V$: $DVDD = 3 V$.
- $3.0V > V_{BAT} > 2.35V$: $DVDD = V_{BAT}$.
- $2.35V > V_{BAT}$: $DVDD = V_{BAT}$ and the PN532 is in reset.

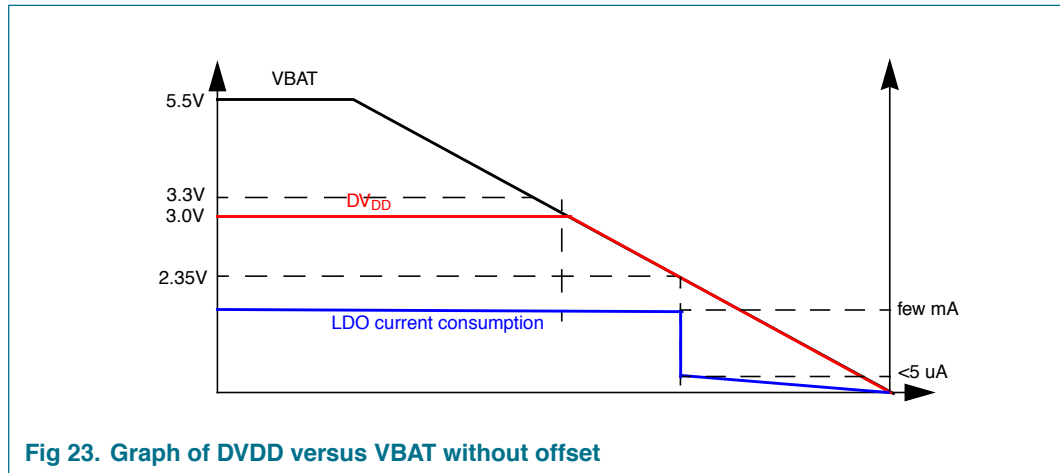

Fig 23. Graph of DVDD versus VBAT without offset

When in Soft-Power-Down mode, the behavior is the same as that with offset. See [Figure 22 on page 85](#).

8.4.1.4 LDO overcurrent detection

The LDO integrates an overcurrent detector. When the current on VBAT exceeds a programmable threshold, an error bit is set. See [Table 126 on page 87](#). If IE1_0 is set to logic 1 (see [Table 13 on page 18](#)), an 80C51 interrupt will be asserted when an overcurrent is detected.

8.4.1.5 LDO register

Table 126. LDO register- (address 6109h) bit allocation

Bit	7	6	5	4	3	2	1	0
Symbol	-	-	overcurrent_status	sel_overcurrent[1:0]	-	enoffset	soft_highspeedreg	control_highspeedreg
Reset	0	0	0	0	0	1	0	0
Access	R	R	R	R/W	R/W	R/W	R/W	R/W

Table 127. Description of LDO bits

Bit	Symbol	Description
7 to 6	-	Reserved
5	overcurrent_status	Set to logic 1 by PN532 when overcurrent is detected. The bit IE1_0 of register IE1 (see Table 13 on page 18) has also to be set to logic 1 to enable the corresponding CPU interrupt.
4 to 3	sel_overcurrent[1:0]	Select overcurrent threshold. 00: 300 mA 01: 210 mA 10: 180 mA 11: 150 mA
2	enoffset	Enable of the LDO offset. When set to logic 1, offset is present.
1	soft_highspeedreg	Control the LDO regulation speed. When set to logic 0, the bandwidth of LDO is reduced to filter bursts on VBAT. When set to logic 1, the bandwidth is increased to establish DVDD supply quickly.
0	control_highspeedreg	Select the control source of the LDO regulation speed. When set to logic 1, LDO bandwidth controlled by soft_highspeedreg. When set to logic 0, LDO bandwidth controlled by output of RF level detector. When RF is detected, bandwidth is reduced.

8.4.2 SVDD switch

The SVDD switch is used to control power to the secure IC. The switch is controlled by register `Control_switch_rng` (address 6106h). The switch is enabled with bit `sic_switch_en`. When disabled, the SVDD pin is tied to ground. A current limiter is incorporated into the switch. Current consumption exceeding 40 mA triggers the limiter and the status bit `sic_switch_overload` is set.

Register `Control_switch_rng` also controls the random generator within the Contactless Interface Unit (CIU).

Table 128. Control_switch_rng register (address 6106h) bit allocation

Bit	7	6	5	4	3	2	1	0
Symbol	-	hide_svdd_sig	sic_switch_overload	sic_switch_en	-	cpu_need_rng	random_dataready	-
Reset	0	1	0	0	0	0	0	1
Access	R	R/W	R	R/W	R	R/W	R/W	R

Table 129. Description of Control_switch_rng bits

Bit	Symbol	Description
7	-	Reserved.
6	hide_svdd_sig	Configures internal state of input signals SIGIN and P34 when idle. This bit can be used to avoid spikes on SIGIN and P34 when the SVDD switch is enabled or disabled. When set to logic 0, internal state of SIGIN and P34 are driven by pads SIGIN and P34 respectively. When set to logic 1, internal state of SIGIN is set to logic 0 and internal state of P34 is set to logic 1.
5	sic_switch_overload	Indicates state of SVDD switch current limiter. When set to logic 0, indicates that current consumption through SVDD switch does not exceed limit (40mA). When set to logic 1, the SVDD switch current limiter is activated.
4	sic_switch_en	Enables or disables power to SVDD switch. When set to logic 0, SVDD switch is disabled and SVDD output is tied to the ground. When set to logic 1, the SVDD switch is enabled and the SVDD output delivers power to secure IC and internal pads (SIGIN, SIGOUT and P34).
3	-	Reserved.
2	cpu_need_rng	Forces random number generator into running mode. When set to logic 0, random number generator is under control of Contactless Interface Unit. When set to logic 1, random number generator is forced to run.
1	random_dataready	Indicates availability of random number. When set to logic 1, a new random number is available. Automatically set to logic 0 when register <code>data_rng</code> (address 6105h) is read.
0	-	Reserved.

8.5 Power clock and reset controller

The PCR controller is responsible for the clock generation, power management and reset mechanism within the PN532.

8.5.1 PCR block diagram

The block diagram shows the relationship between the PCR, other embedded blocks and external signals.

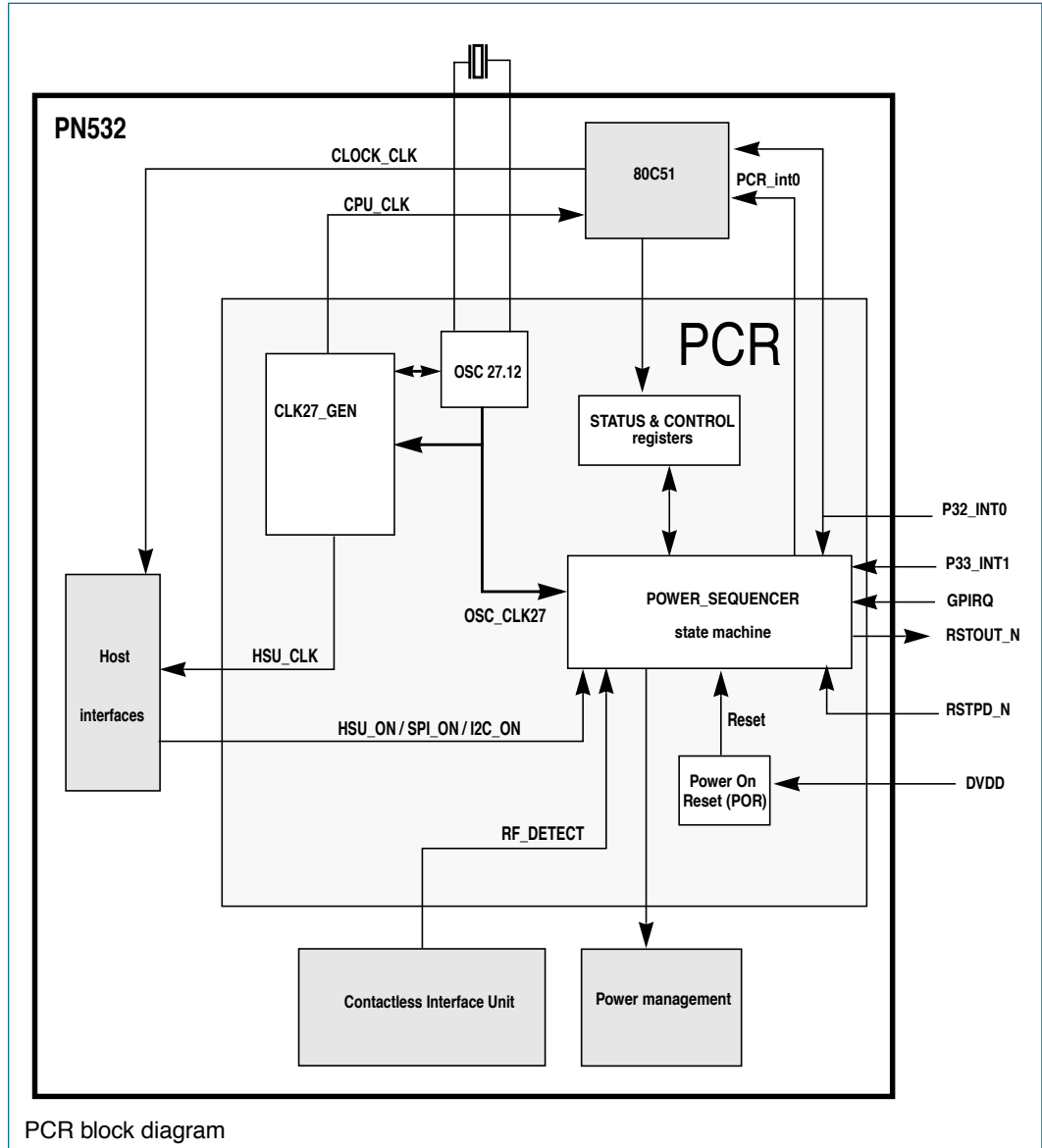

Table 130. PN532 clock source characteristics

Clock name	Frequency MHz	Tolerance	Clock source	Comments
OSC_CLK27	27.12	± 14 kHz	OSC 27.12	Output of OSC 27
CPU_CLK	27.12/13.56/6.78	± 500 ppm	OSC 27.12	Default is 6.78 MHz
HSU_CLK	27.12	± 14 kHz	OSC 27.12	

8.5.2 27.12 MHz crystal oscillator

The 27.12 MHz clock applied to the PN532 is the time reference for the embedded microcontroller. Therefore stability of the clock frequency is an important factor for reliable operation. It is recommended to adopt the circuit shown in [Figure 24](#).

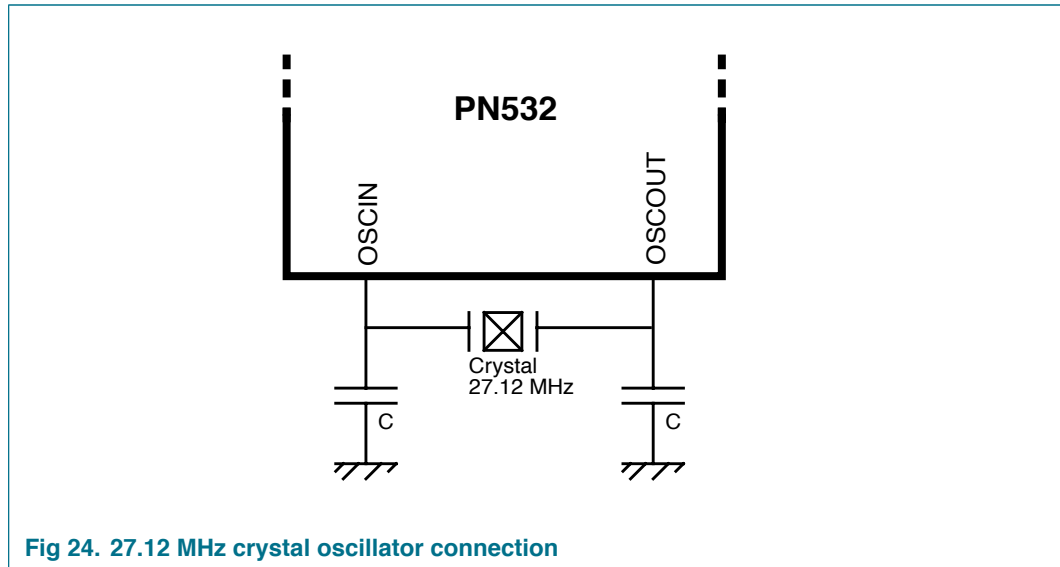

Fig 24. 27.12 MHz crystal oscillator connection

8.5.3 Reset modes

The possible reset mechanisms are listed below:

- Supply rail variation

When DVDD falls below 2.4 V, the POR (Power-On-Reset) asserts an internal reset signal. The Power Sequencer disables all clocks. When DVDD rises above 2.4V, the POR deasserts the internal reset signal and the Power Sequencer starts the power-up sequence. Once the PN532 is out of reset, the RSTOUT_N pin is driven high.

- Glitch on DVDD

When DVDD falls below 2.35 V for more than 1 ms, the POR asserts an internal reset signal. The power sequencer starts the Power-down sequence. The PN532 goes into reset and the RSTOUT_N signal is driven low.

- Hard Power Down mode (HPD)

When RSTPD_N is set to logic 0, the PN532 goes into Hard Power Down (HPD) mode. The PN532 goes into reset and the RSTOUT_N signal is driven low. The power consumption is at the minimum. DVDD is tied to ground and ports are disconnected from their supply rails.

When in Hard Power Down mode, the GPIO pins are forced in quasi bidirectional mode. Referring to [Figure 7 on page 41](#), $e_n = e_{pu} = "1"$, $e_p = "0"$. $e_{hd} = "1"$ if GPIO pin value is "1" and $e_{hd} = "0"$ if GPIO pin value is "0".

8.5.4 Soft-Power-Down mode (SPD)

In order to initiate the Soft-Power-Down mode with minimal power consumption, the firmware should:

- Configure I/Os to minimize power consumption. Be careful that for P32_INT0, referring to [Section 8.2.1 “Pad configurations description” on page 40](#), e_hd is forced to logic 1.
- Shut down unused functions
 - Contactless Interface Unit with bit Power-down of SFR register D1h, see [Table 179 on page 145](#).
 - Disable the SVDD switch, see [Table 129 on page 88](#)
 - Power down the RF level detector if RF wake up is not enabled, see [Table 287 on page 187](#).
- Enable relevant wake-up sources
- Disable unwanted interrupts
- Assert bit CPU_PD in register PCON, see [Table 7 on page 16](#)

When bit CPU_PD is set, all clocks are stopped and the LDO is put into Soft-Power-Down mode. Finally, the Power Sequencer goes into Stopped state.

8.5.5 Low power modes

There are 2 different low power modes.

- Hard-Power-Down mode (HPD): controlled by the pin RSTPD_N. The PN532 goes into reset and power consumption is at a minimum, see [Section 8.5.3 “Reset modes”](#).
- Soft-Power-Down mode (SPD): controlled by firmware. See [Section 8.5.4 “Soft-Power-Down mode \(SPD\)”](#) to optimize the power consumption in this mode.

Table 131. Current consumption in low power modes

Mode	Conditions	Maximum current consumption
Hard-Power-Down	RSTPD_N is set to logic 0	2 μ A
Soft-Power-Down with no RF detector	Sequence of Section 8.5.4 is applied	40 μ A
Soft-Power-Down with RF detector active	Sequence of Section 8.5.4 is applied	45 μ A

8.5.6 Remote wake-up from SPD

The PN532 can be woken up from a Soft-Power-Down mode when an event occurs on one of the wake up sources, which has been enabled. There are eight wake-up sources:

- P32_INT0
- P33_INT1
- RF field detected (RF_DETECT)
- HSU wake-up (HSU_ON)
- I²C wake-up (I²C_ON)
- SPI wake-up (SPI_ON)
- NFC_WI counters
- GPIRQ: P34, P35, P50_SCL, P71.

When one of these signals is asserted, if its corresponding enable bit is set (see [Table 144 on page 96](#)), the Power Sequencer starts the wake-up sequence. The wake up event can only be serviced if the Power Sequencer is in the Stopped state, which means the PN532 is fully entered in Soft-Power-Down mode.

[Figure 25](#) illustrates the wake-up mechanism, using an event on P33_INT1 as an example. CPU_CLK is active T1 after the falling edge of P33_INT1 and the PN532 is ready. T1 depends on the choice of crystal oscillator and its layout. For devices such as TAS-3225A, TAS-7 or KSS2F, T1 is a maximum of 2ms. Exit from the Power-down mode is signaled by CPU_PD going low one clock cycle later.

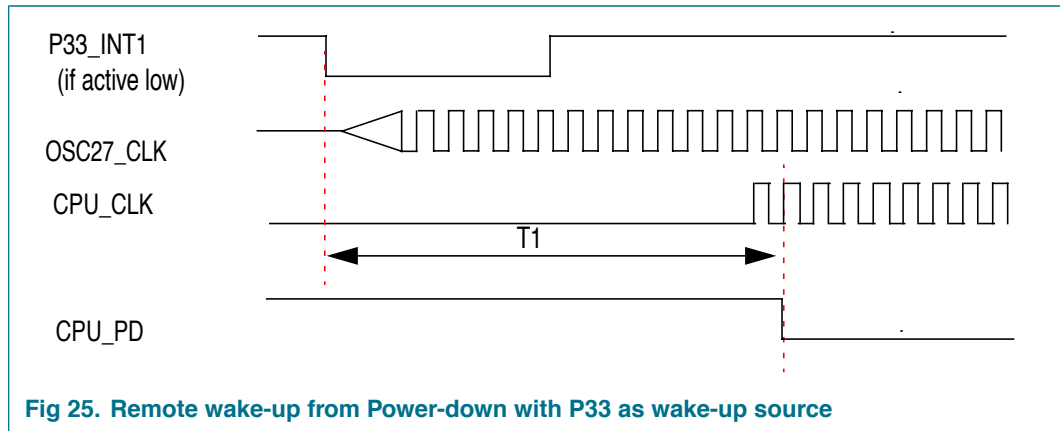

8.5.7 PCR extension registers

The PCR is controlled via several registers given in [Table 132](#):

Table 132. PCR registers

Name	Size [bytes]	Address offset	Description	Reset	R/W
CFR	1	6200h	Clock Frequency Register	02	R/W
CER	1	6201h	Clock Enable Register	0E	R/W
ILR	1	6202h	Interrupt Level Register	40	R/W
Control	1	6203h	Control	C0	R/W
Status	1	6204h	Status	00	R
Wakeupen	1	6205h	Wake-up Enable	00	R/W

8.5.8 PCR register description

8.5.8.1 CFR register

The Clock Frequency Register is used to select the frequency of the CPU and its associated peripherals. The clock frequency can be changed dynamically by writing to this register at any time.

Table 133. PCR CFR register- (address 6200h) bit allocation

Bit	7	6	5	4	3	2	1	0
Symbol	-	-	-	-	-	-	cpu_freq[1:0]	
Reset	0	0	0	0	0	0	1	0
Access	R	R	R	R	R	R	R/W	R/W

Table 134. Description of PCR CFR bits

Bit	Symbol	Description
7 to 2	-	Reserved
1 to 0	cpu_frq[1:0]	Select CPU clock frequency.
	cpu_frq[1:0]	CPU clock frequency
	00	27.12 MHz
	01	13.56 MHz
	10	6.78 MHz
	11	27.12 MHz

8.5.8.2 CER register

The Clock Enable Register is used to enable or disable the clock of the HSU (frequency is fixed at 27.12 MHz). The clock can be switched on or off at any time.

Table 135. PCR CER register (address 6201h) bit allocation

Bit	7	6	5	4	3	2	1	0
Symbol	-	-	-	-	hsu_enable	-	-	-
Reset	0	0	0	0	1	1	1	0
Access	R	R	R	R	R/W	R	R	R

Table 136. Description of PCR CER bits

Bit	Symbol	Description
7 to 4	-	Reserved.
3	hsu_enable	Enable HSU clock. When 1, HSU is enabled. When 0, HSU is disabled.
2 to 0	-	Reserved.

8.5.8.3 ILR register

The Interrupt Level Register is used to program the level of the external interrupts. Firmware can write to this register at any time.

Table 137. PCR ILR register (address 6202h) bit allocation

Bit	7	6	5	4	3	2	1	0
Symbol	-	porpulse_latched	-	enable_pdselif	-	gpirq_level	int1_level	int0_level
Reset	0	1	0	0	0	0	0	0
Access	R	R/W	R	R/W	R	R/W	R/W	R/W

Table 138. Description of PCR ILR bits

Bit	Symbol	Description												
7	-	Reserved												
6	porpulse_latched	Indicates that a reset has been generated. When set to logic 1, indicates that the system has been reset. The firmware can write a “0” during the firmware reset sequence.												
5	-	Reserved												
4	enable_pdselif	Indicates that a reset has been generated. When set to logic 1, P33_INT1 directly controls state of host interface pins: <ul style="list-style-type: none"> If P33_INT1 is set to logic 1, host interface output pins are driven according to selected interface protocol If P33_INT1 is set to logic 0, host interface output pins are set into high-impedance state When set to logic 0, P33_INT1 does not control host interface pins. Their state is determined by selected interface protocol. <table border="1" style="margin-left: 20px;"> <thead> <tr> <th>enable_pdselif</th> <th>P33_INT1</th> <th>State of host interface pins</th> </tr> </thead> <tbody> <tr> <td>0</td> <td>x</td> <td>Active</td> </tr> <tr> <td>1</td> <td>0</td> <td>High Impedance</td> </tr> <tr> <td>1</td> <td>1</td> <td>Active</td> </tr> </tbody> </table>	enable_pdselif	P33_INT1	State of host interface pins	0	x	Active	1	0	High Impedance	1	1	Active
enable_pdselif	P33_INT1	State of host interface pins												
0	x	Active												
1	0	High Impedance												
1	1	Active												
3	-	Reserved.												
2	gpirq_level	Selects gpirq interrupt level. When set to logic 1, wake-up condition is true when gpirq is high. When set to logic 0, wake-up condition is true when gpirq is low.												
1	int1_level	Selects P33_INT1 interrupt level. When set to logic 1, wake-up condition is true when P33_INT1 is low. When set to logic 0, wake-up condition is true when P33_INT1 is high.												
0	int0_level	Selects P32_INT0 interrupt level. When set to logic 1, wake-up condition is true when P32_INT0 is high. When set to logic 0, wake-up condition is true when P32_INT0 is low.												

8.5.8.4 PCR Control register

The Control register is used to perform a firmware reset and clear wake-up conditions in the Status register.

Table 139. PCR Control register (address 6203h) bit allocation

Bit	7	6	5	4	3	2	1	0
Symbol	-	-	-	-	-	-	clear_wakeup_cond	soft_reset
Reset	1	1	0	0	0	0	0	0
Access	R	R	R	R	R	R	R/W	R/W

Table 140. Description of PCR Control bits

Bit	Symbol	Description
7 to 2	-	Reserved.
1	clear_wakeup_cond	Clears value of wakeupcond in Status register. When set to logic 1, wake-up conditions stored in PCR Status register are set to logic 0. Bit is set to logic 0 automatically by hardware.
0	soft_reset	Initiates a firmware reset. When set to logic 1, system goes into firmware reset mode. Bit is set to logic 0 automatically by hardware after performing firmware reset sequence.

8.5.8.5 PCR Status register

The PCR Status register stores the state of the 8 wake-up events, reported within 7 flags.

Remark: The following status bits are not masked by the corresponding enable bit of the PCR Wakeupen register (see [Table 143](#)). But if not enabled, the event does not wake-up the PN532.

Remark: Be careful when handling the status register, not all the status events are latched. Therefore it be possible that the status register does not indicate any wake-up event when reading this register after wake-up.

Remark: There is no priority management. More than one wake-up event may be signalled in the register. Therefore it may not be possible to detect the source of the wake-up event by reading this register.

Table 141. PCR Status register (address 6204h) bit allocation

Bit	7	6	5	4	3	2	1	0
Symbol	i ² c_wu	gpirq_wu	SPI_wu	HSU_wu	CIU_wu	-	int1_wu	int0_wu
Reset	0	0	0	0	0	0	0	0
Access	R	R	R	R	R	R	R	R

An event on a given wake-up condition is flagged by a logic 1 in the associated bit field.

Table 142. Description of PCR Status bits

Bit	Symbol	Description
7	i ² c_wu	I²C wake-up event (on its own address). Set to logic 1, when PN532 woke up due to recognition of its own I ² C address appearing on I ² C interface ^[1] .
6	gpirq_wu	gpirq wake-up event (or function of P34, P35, P50_SCL and P71 signals when enabled and level-controlled). Set to logic 1, when PN532 woke up from a GIRQ event (GPIRQ at logic 0) ^[2] .
5	SPI_wu	SPI wake-up event (spi_on signal). Set to logic 1, when PN532 woke up from a SPI event (NSS at logic 0) ^[2] .
4	HSU_wu	HSU wake-up event (hsu_on signal). Set to logic 1, when PN532 woke up from a HSU event (5 rising edges on HSU_RX) ^[1] .
3	CIU_wu	Contactless wake-up event. RF detected signal ^[2] or NFC-WI event ^[1] . Set to logic 1, when PN532 woke up from a Contactless interrupt.
-	-	Reserved.
1	int1_wu	P33_INT1 wake-up event. Set to logic 1, when the system woke up from a P33_INT1 interrupt ^[2] .
0	int0_wu	P32_INT0 wake-up event. Set to logic 1, when the system woke up from a P32_INT0 interrupt. ^[2]

[1] This wake-up event is latched. The firmware must set the status byte to logic 0 after reading it (by writing a logic 1 to bit clear_wakeup_cond in register PCR Control)

[2] If this wake-up event does not last up to the CPU clock is available, it will not be available within the status register; it is not latched when no CPU clock is available and it directly reflects the state of the event.

8.5.8.6 PCR Wakeupen register

Register Wakeupen allows the selection of different wake-up events.

Table 143. PCR Wakeupen register (address 6205h) bit allocation

Bit	7	6	5	4	3	2	1	0
Symbol	i ² c_wu_en	GPIRQ_wu_en	SPI_on_en	HSU_on_en	CIU_wu_en	-	int1_en	int0_en
Reset	0	0	0	0	0	0	0	0
Access	R/W	R/W	R/W	R/W	R/W	R	R/W	R/W

Table 144. Description of PCR Wakeupen bits

Bit	Symbol	Description
7	i ² c_wu_en	I²C wake-up source enable. When set to logic 1, I ² C event (recognition of its own address) can wake up PN532. See Table 90 on page 64 to enable the corresponding event.
6	GPIRQ_wu_en	General Purpose IRQ wake-up source enable. When set to logic 1, a GPIRQ event can wake up PN532.
5	SPI_on_en	SPI wake-up source enable. When set to logic 1, a SPI event can wake up PN532.
4	HSU_on_en	HSU wake-up source enable. When set to logic 1, an HSU event can wake up PN532. See Table 114 on page 76 to enable the corresponding event.
3	CIU_wu_en	Contactless Interface Unit wake-up source enable. When set to logic 1, a CIU event (RF detected or NFC-WI event) can wake up PN532.

Table 144. Description of PCR Wakeupen bits ...continued

Bit	Symbol	Description
2	-	Reserved.
1	int1_en	P33_INT1 wake-up source enable. When set to logic 1, a P33_INT1 event can wake up PN532.
0	int0_en	P32_INT0 wake-up source enable. When set to logic 1, a P32_INT0 event can wake up PN532.

8.6 Contactless Interface Unit (CIU)

The PN532 CIU is a modem for contactless communication at 13.56 MHz. It supports 6 different operating modes

- ISO/IEC 14443A/MIFARE Reader/Writer.
- FeliCa Reader/Writer.
- ISO/IEC 14443B Reader/Writer
- ISO/IEC 14443A/MIFARE Card 1 KB or MIFARE 4 KB emulation
- FeliCa Card emulation
- ISO/IEC 18092, ECMA 340 NFCIP-1 Peer-to-Peer

The CIU implements a demodulator and decoder for signals from ISO/IEC 14443A/MIFARE compatible cards and transponders. The CIU handles the complete ISO/IEC 14443A framing and error detection (Parity & CRC).

The CIU supports MIFARE 1 KB or MIFARE 4 KB emulation (e.g. MIFARE 1 KB or MIFARE 4 KB emulation) products. The CIU supports contactless communication using MIFARE Higher transfer speeds up to 424 kbit/s in both directions.

The CIU can demodulate and decode FeliCa coded signals. The CIU digital part handles the FeliCa framing and error detection. The CIU supports contactless communication using FeliCa Higher transfer speeds up to 424 kbit/s in both directions.

The CIU supports layers 2 and 3 of the ISO/IEC 14443 B Reader/Writer communication scheme, except anticollision which must be implemented in firmware as well as upper layers.

In card emulation mode, the CIU is able to answer to a Reader/Writer command either according to the FeliCa or ISO/IEC 14443A/MIFARE card interface scheme. The CIU generates the load modulation signals, either from its transmitter or from the LOADMOD pin driving an external active circuit. A complete secure card functionality is only possible in combination with a secure IC using the NFC-WI/S²C interface.

Compliant to ECMA 340 and ISO/IEC 18092 NFCIP-1 Passive and Active communication modes, the CIU offers the possibility to communicate to another NFCIP-1 compliant device, at transfer speeds up to 424 kbit/s. The CIU handles the complete NFCIP-1 framing and error detection.

The CIU transceiver can be connected to an external antenna for Reader/Writer or Card/PICC modes, without any additional active component.

8.6.1 Feature list

- Frequently accessed registers placed in SFR space
- Highly integrated analog circuitry to demodulate and decode received data
- Buffered transmitter drivers to minimize external components to connect an antenna.
- Integrated RF level detector
- Integrated data mode detector
- Typical operating distance of 50 mm in ISO/IEC 14443A/MIFARE or FeliCa in Reader/Writer mode depending on the antenna size, tuning and power supply
- Typical operating distance of 50 mm in NFCIP-1 mode depending on the antenna size, tuning and power supply
- Typical operating distance in ISO/IEC 14443A/MIFARE card or FeliCa card operation mode of about 100 mm depending on the antenna size, tuning and the external field strength
- Supports MIFARE 1 KB or MIFARE 4 KB emulation encryption in Reader/Writer mode
- Supports MIFARE higher data rate at 212 kbit/s and 424 kbit/s
- Supports contactless communication according to the FeliCa scheme at 212 kbit/s and 424 kbit/s
- Support of the NFC-WI/S²C interface
- 64 byte send and receive FIFO-buffer
- Programmable timer
- CRC Co-processor
- Internal self test and antenna presence detector
- 2 interrupt sources
- Adjustable parameters to optimize the transceiver performance according to the antenna characteristics

8.6.2 Simplified block diagram

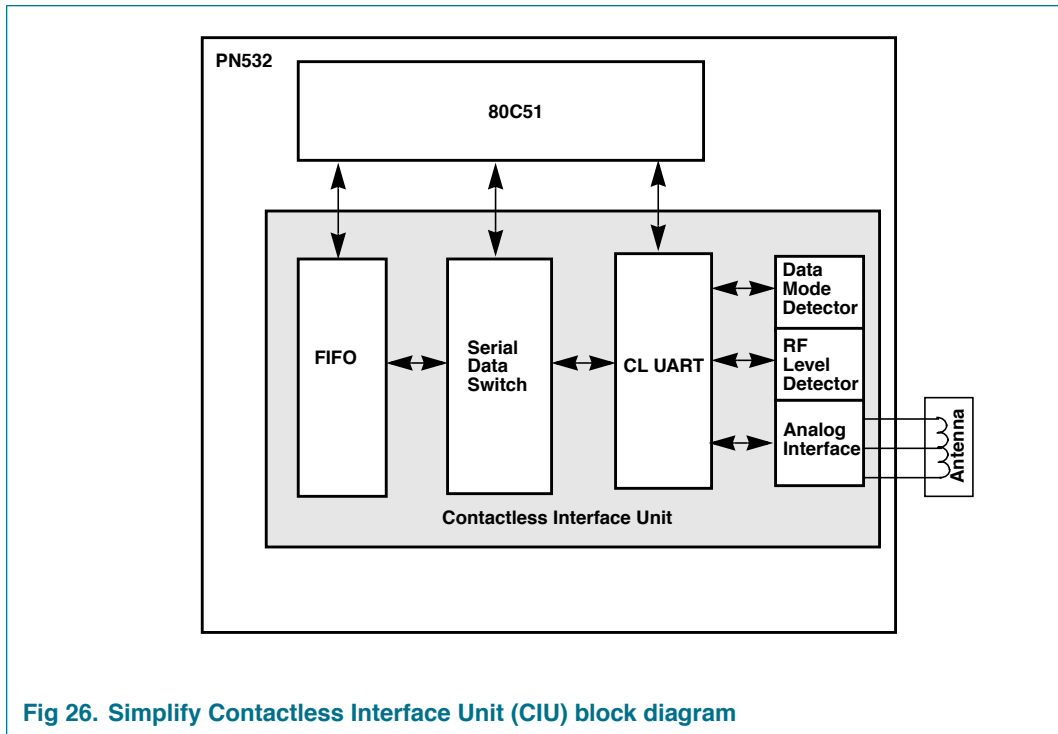

Fig 26. Simplify Contactless Interface Unit (CIU) block diagram

The Analog Interface handles the modulation and demodulation of the analog signals according to the Card emulation mode, Reader/Writer mode and NFCIP-1 mode communication scheme.

The RF level detector detects the presence of an external RF-field delivered by the antenna to the RX pin.

The data mode detector detects a ISO/IEC 14443-A MIFARE, FeliCa or NFCIP-1 mode in order to prepare the internal receiver to demodulate signals, which are sent to the PN532.

The NFC-WI/S²C interface supports communication to secure IC. It also supports digital signals for transfer speeds above 424 kbit/s.

The CL UART handles the protocol requirements for the communication schemes in co-operation with the appropriate firmware. The FIFO buffer allows a convenient data transfer from the 80C51 to the CIU and vice versa.

8.6.3 Reader/Writer modes

All indicated modulation indices and modes in this chapter are system parameters. This means that beside the IC settings a suitable antenna tuning is required to achieve the optimal performance.

8.6.3.1 ISO/IEC 14443A Reader/Writer

The following diagram describes the communication on a physical level, the communication overview in the [Table 145](#) describes the physical parameters.

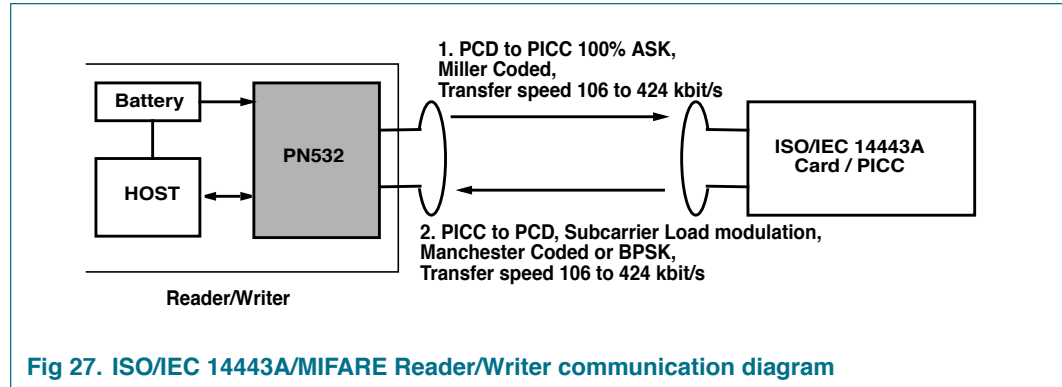

Fig 27. ISO/IEC 14443A/MIFARE Reader/Writer communication diagram

Table 145. Communication overview for ISO/IEC 14443A/MIFARE Reader/Writer

Communication scheme		ISO/IEC 14443A MIFARE	MIFARE Higher Baud Rate	
Baud rate		106 kbit/s	212 kbit/s	424 kbit/s
Bit length		$\frac{128}{13.56MHz} \approx 9.44\mu s$	$\frac{64}{13.56MHz} \approx 4.72\mu s$	$\frac{32}{13.56MHz} \approx 2.36\mu s$
PN532 to PICC/Card	Modulation	100% ASK	100% ASK	100% ASK
	Bit coding	Modified Miller coding	Modified Miller coding	Modified Miller coding
PICC/Card to PN532	Modulation	Subcarrier load modulation	Subcarrier load modulation	Subcarrier load modulation
	Subcarrier frequency	$13.56 MHz/_{16}$	$13.56 MHz/_{16}$	$13.56 MHz/_{16}$
	Bit coding	Manchester coding	BPSK	BPSK

The internal CRC co-processor calculates the CRC value according the data coding and framing defined in the ISO/IEC 14443A part 3, and handles parity generation internally according to the transfer speed.

With appropriate firmware, the PN532 can handle the complete ISO/IEC 14443A/MIFARE protocol.

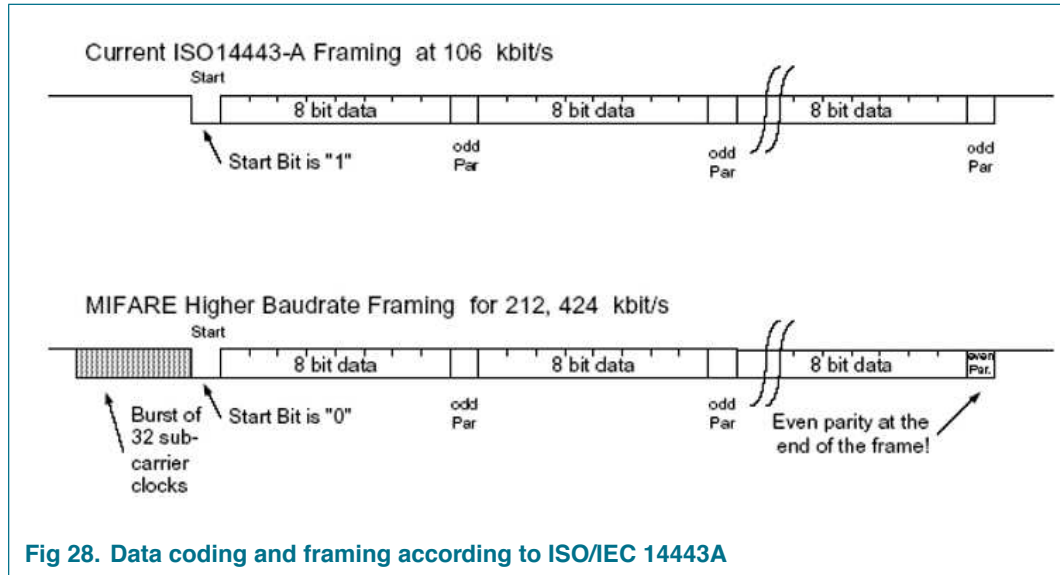

Fig 28. Data coding and framing according to ISO/IEC 14443A

8.6.3.2 FeliCa Reader/Writer

The following diagram describes the communication at the physical level. [Table 146](#) describes the physical parameters.

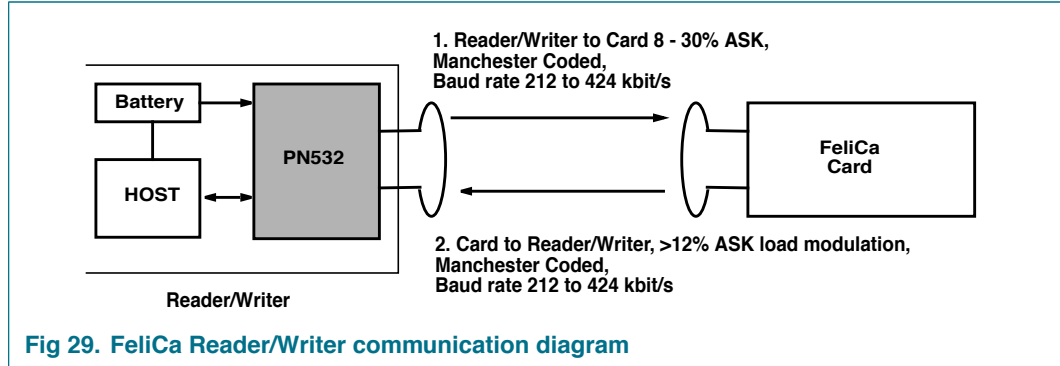

Table 146. Communication overview for FeliCa Reader/Writer

Communication scheme		FeliCa	FeliCa higher baud rate
Baud rate		212 kbit/s	424 kbit/s
Bit length		$\frac{64}{13.56MHz} \approx 4.72\mu s$	$\frac{32}{13.56MHz} \approx 2.36\mu s$
PN532 to PICC/Card	Modulation	8 - 30% ASK	8 - 30% ASK
	Bit coding	Manchester coding	Manchester coding
PICC/Card to PN532	Modulation	>12% ASK	>12% ASK
	Bit coding	Manchester coding	Manchester coding

With appropriate firmware, the PN532 can handle the FeliCa protocol.

The FeliCa Framing and coding must comply with the following table:

Table 147. FeliCa Framing and Coding

Preamble						SYNC		LEN	n-Data				CRC	
00h	00h	00h	00h	00h	00h	B2h	4Dh							

To enable the FeliCa communication a 6-byte preamble (00h, 00h, 00h, 00h, 00h, 00h) and 2-byte SYNC bytes (B2h, 4Dh) are sent to synchronize the receiver.

The following LEN byte indicates the length of the sent data bytes plus the LEN byte itself. The CRC calculation is done according to the FeliCa definitions with the MSB first.

To transmit data on the RF interface, the 80C51 has to send the LEN and data bytes to the CIU. The Preamble and SYNC bytes are generated by the CIU automatically and must not be written to the FIFO. The CIU performs internally the CRC calculation and adds the result to the frame.

The starting value for the CRC Polynomial is 2 null bytes: (00h), (00h)

Example of frame:

Table 148. FeliCa framing and coding

Preamble						SYNC		LEN	2 Data Bytes		CRC	
00	00	00	00	00	00	B2	4D	03	AB	CD	90	35

8.6.3.3 ISO/IEC 14443B Reader/Writer

The CIU supports layers 2 and 3 of the ISO/IEC 14443 B Reader/Writer communication scheme, except anticollision which must be implemented in firmware as well as upper layers.

The following diagram describes the communication at the physical level. [Table 149](#) describes the physical parameters.

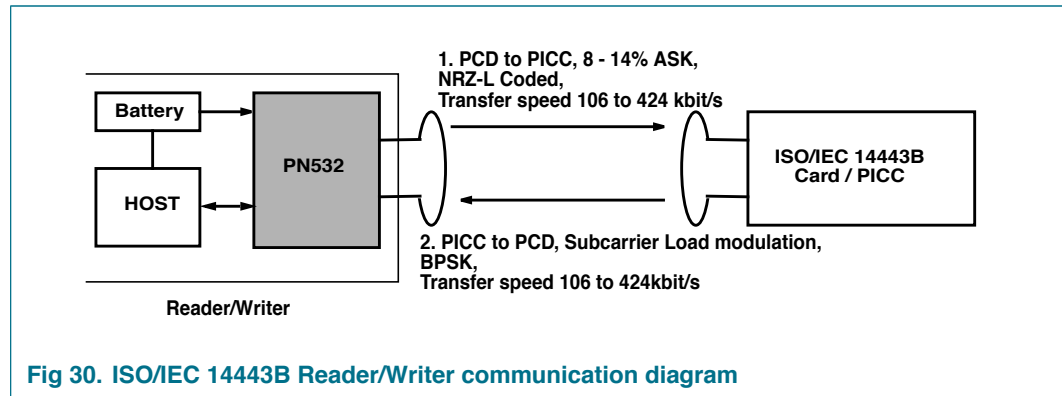

Fig 30. ISO/IEC 14443B Reader/Writer communication diagram

With appropriate firmware, the PN532 can handle the ISO/IEC 14443B protocol.

Table 149. Communication overview for ISO/IEC 14443B Reader/Writer

Communication scheme		ISO/IEC 14443B	Type B higher baud rate	
Baud rate		106 kbit/s	212 kbit/s	424 kbit/s
Bit length		$\frac{128}{13.56MHz} \approx 9.44\mu.s$	$\frac{64}{13.56MHz} \approx 4.72\mu.s$	$\frac{32}{13.56MHz} \approx 2.36\mu.s$
PN532 to PICC/Card	Modulation	8 -14% ASK	8 -14% ASK	8 -14% ASK
	Bit coding	NRZ-L	NRZ-L	NRZ-L
PICC/Card to PN532	Modulation	Subcarrier load modulation	Subcarrier load modulation	Subcarrier load modulation
	Subcarrier frequency	13.56 MHz ₁₆	13.56 MHz ₁₆	13.56 MHz ₁₆
	Bit coding	BPSK	BPSK	BPSK

8.6.4 ISO/IEC 18092, ECMA 340 NFCIP-1 operating mode

A NFCIP-1 communication takes place between 2 devices:

- Initiator: generates RF field at 13.56 MHz and starts the NFCIP-1 communication.
- Target: responds to initiator command either in a load modulation scheme in Passive Communication mode or using a self generated and self modulated RF field for Active Communication mode.

The NFCIP-1 communication differentiates between Active and Passive communication modes.

- Active Communication mode means both the initiator and the target are using their own RF field to transmit data
- Passive Communication mode means that the Target answers to an Initiator command in a load modulation scheme. The Initiator is active in terms of generating the RF field.

In order to fully support the NFCIP-1 standard the PN532 supports the Active and Passive Communications mode at the transfer speeds 106 kbit/s, 212 kbit/s and 424 kbit/s as defined in the NFCIP-1 standard

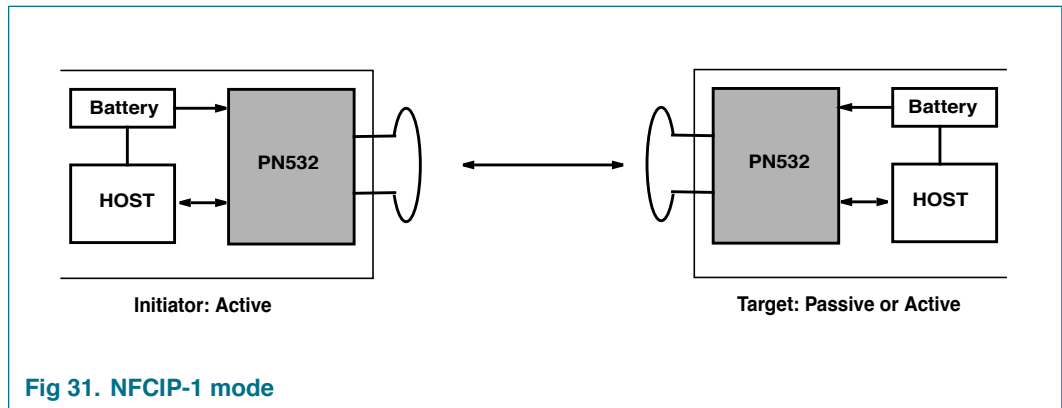
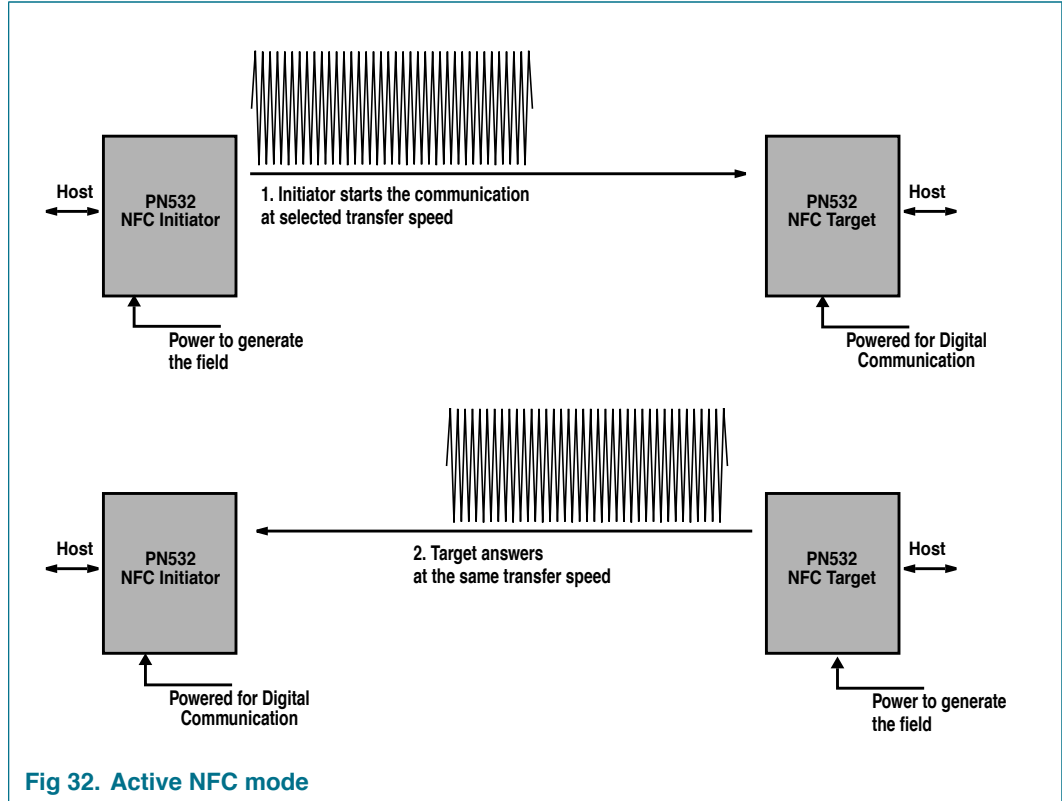

Fig 31. NFCIP-1 mode

With appropriate firmware, the PN532 can handle the NFCIP-1 protocol, for all communication modes and data rates, for both Initiator and Target.

8.6.4.1 ACTIVE Communication mode

Active Communication Mode means both the Initiator and the Target are using their own RF field to transmit data.



The following table gives an overview of the active communication modes:

Table 150. Communication overview for NFC Active Communication mode

Communication scheme		ISO/IEC 18092, ECMA 340, NFCIP-1		
Baud rate		106 kbit/s	212 kbit/s	424 kbit/s
Bit length		$\frac{128}{13.56MHz} \approx 9.44\mu s$	$\frac{64}{13.56MHz} \approx 4.72\mu s$	$\frac{32}{13.56MHz} \approx 2.36\mu s$
Initiator to Target	Modulation	100% ASK	8-30%ASK	8-30%ASK
	Bit coding	Miller Coded	Manchester Coded	Manchester Coded
Target to Initiator	Modulation	100% ASK	8-30%ASK	8-30%ASK
	Bit coding	Miller Coded	Manchester Coded	Manchester Coded

8.6.4.2 PASSIVE Communication mode

Passive Communication Mode means that the target answers to an Initiator command in a load modulation scheme.

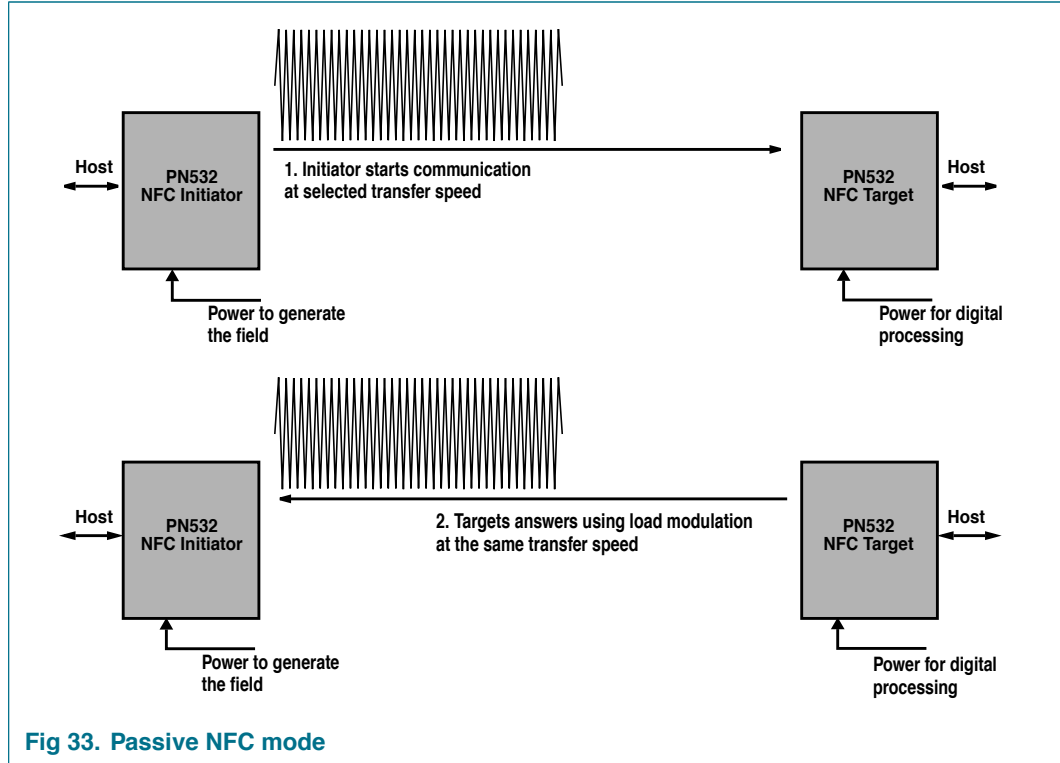

Fig 33. Passive NFC mode

The following table gives an overview of the active communication modes:

Table 151. Communication overview for NFC Passive Communication mode

Communication scheme		ISO/IEC 18092, ECMA 340, NFCIP-1		
Baud rate		106 kbit/s	212 kbit/s	424 kbit/s
Bit length		$\frac{128}{13.56\text{MHz}} \approx 9.44\mu\text{s}$	$\frac{64}{13.56\text{MHz}} \approx 4.72\mu\text{s}$	$\frac{32}{13.56\text{MHz}} \approx 2.36\mu\text{s}$
PN532 to PICC/Card	Modulation	100% ASK	100% ASK	100% ASK
	Bit coding	Modified Miller coding	Modified Miller coding	Modified Miller coding
PICC/Card to PN532	Modulation	Subcarrier load modulation	>12% ASK	>12% ASK
	Subcarrier frequency	13.56 MHz ₁₆	No subcarrier	No subcarrier
	Bit coding	Manchester coding	Manchester coding	Manchester coding

8.6.4.3 NFCIP-1 framing and coding

The NFCIP-1 framing and coding in Active and Passive communication modes are defined in the NFCIP-1 standard: ISO/IEC 18092 or ECMA 340.

8.6.4.4 NFCIP-1 protocol support

The NFCIP-1 protocol is not completely described in this document. For detailed explanation of the protocol refer to the ISO/IEC 18092 / ECMA340 NFCIP-1 standard. However the datalink layer is according to the following policy:

- Transaction includes initialization, anticollision methods and data transfer. This sequence must not be interrupted by another transaction.
- Speed should not be changed during a data transfer

In order not to disturb current infrastructure based on 13.56 MHz general rules to start NFC communication are defined in the following way:

- Per default NFCIP-1 device is in target mode, meaning its RF field is switched off.
- The RF level detector is active.
- Only if application requires the NFCIP-1 device shall switch to Initiator mode.
- Initiator shall only switch on its RF field if no external RF field is detected by RF Level detector during a time of TIDT.
- The initiator performs initialization according to the selected mode.

8.6.5 Card operating modes

The PN532 can be addressed like a FeliCa or ISO/IEC 14443A/MIFARE card. This means that the PN532 can generate an answer in a load modulation scheme according to the ISO/IEC 14443A/MIFARE or FeliCa interface description.

Remark: The PN532 does not support a secure storage of data. This has to be handled by a dedicated secure IC or a host. The secure IC is optional.

Remark: The PN532 can not be powered by the field in this mode and needs a power supply.

8.6.5.1 ISO/IEC 14443A/MIFARE card operating mode

With appropriate firmware, the PN532 can handle the ISO/IEC 14443A including the level 4, and the MIFARE protocols.

The following diagram describes the communication at the physical level. [Table 152](#) describes the physical parameters.

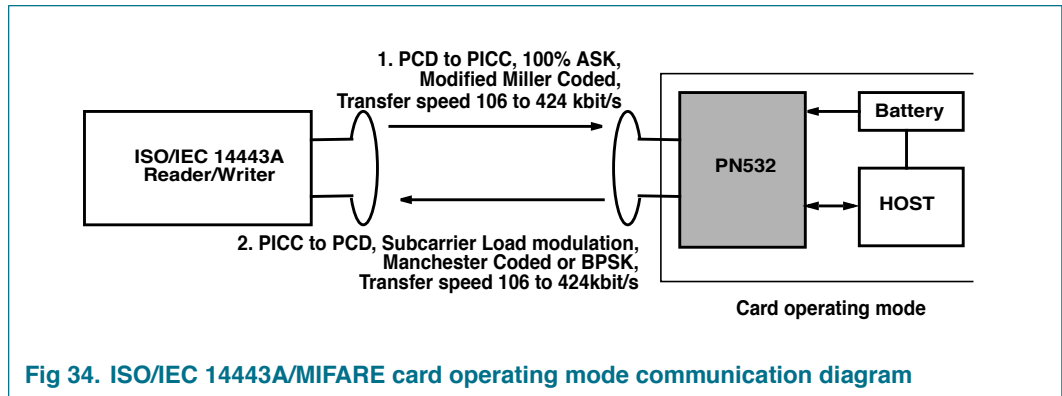

Fig 34. ISO/IEC 14443A/MIFARE card operating mode communication diagram

Table 152. Communication overview for ISO/IEC 14443A/MIFARE Card operating mode

Communication scheme		ISO/IEC 14443A MIFARE	MIFARE higher baud rate	
Baud rate		106 kbit/s	212 kbit/s	424 kbit/s
Bit length		$\frac{128}{13.56MHz} \approx 9.44\mu s$	$\frac{64}{13.56MHz} \approx 4.72\mu s$	$\frac{32}{13.56MHz} \approx 2.36\mu s$
Reader/Writer to PN532	Modulation	100% ASK	100% ASK	100% ASK
	Bit coding	Modified Miller coding	Modified Miller coding	Modified Miller coding
PN532 to Reader/Writer	Modulation	Subcarrier load modulation	Subcarrier load modulation	Subcarrier load modulation
	Subcarrier frequency	13.56 MHz _{/16}	13.56 MHz _{/16}	13.56 MHz _{/16}
	Bit coding	Manchester coding	BPSK	BPSK

8.6.5.2 FeliCa Card operating mode

With appropriate firmware, the PN532 can handle the FeliCa protocol.

The following diagram describes the communication at the physical level. [Table 153](#) describes the physical parameters.

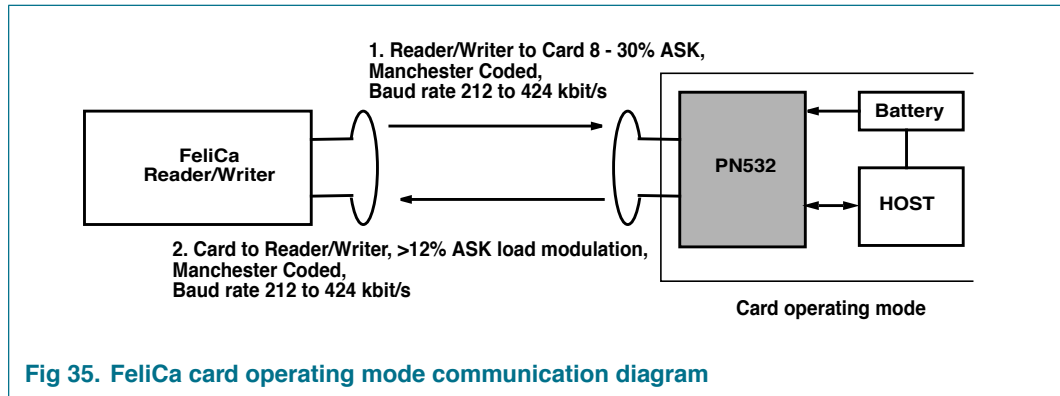

Fig 35. FeliCa card operating mode communication diagram

Table 153. Communication overview for FeliCa Card operating mode

Communication scheme		FeliCa	FeliCa higher baud rate
Baud rate		212 kbit/s	424 kbit/s
Bit length		$\frac{64}{13.56MHz} \approx 4.72\mu s$	$\frac{32}{13.56MHz} \approx 2.36\mu s$
Reader/Writer to PN532	Modulation	8 - 30% ASK	8 - 30% ASK
	Bit coding	Manchester coding	Manchester coding
PN532 to Reader/Writer	Modulation	>12% ASK	>12% ASK
	Bit coding	Manchester coding	Manchester coding

8.6.6 Overall CIU block diagram

The PN532 supports different contactless communication modes. The CIU supports the internal 80C51 for the different selected communication schemes such as Card Operation mode, Reader/Writer Operating mode or NFCIP-1 mode up to 424 kbit/s. The CIU generates bit- and byte-oriented framing and handles error detection according to these different contactless protocols.

Higher transfer speeds up to 3.39 Mbit/s can be handled by the digital part of the CIU. To modulate and demodulate the data an external circuit has to be connected to the communication interface pins SIGIN/SIGOUT.

Remark: The size and tuning of the antenna have an important impact on the achievable operating distance.

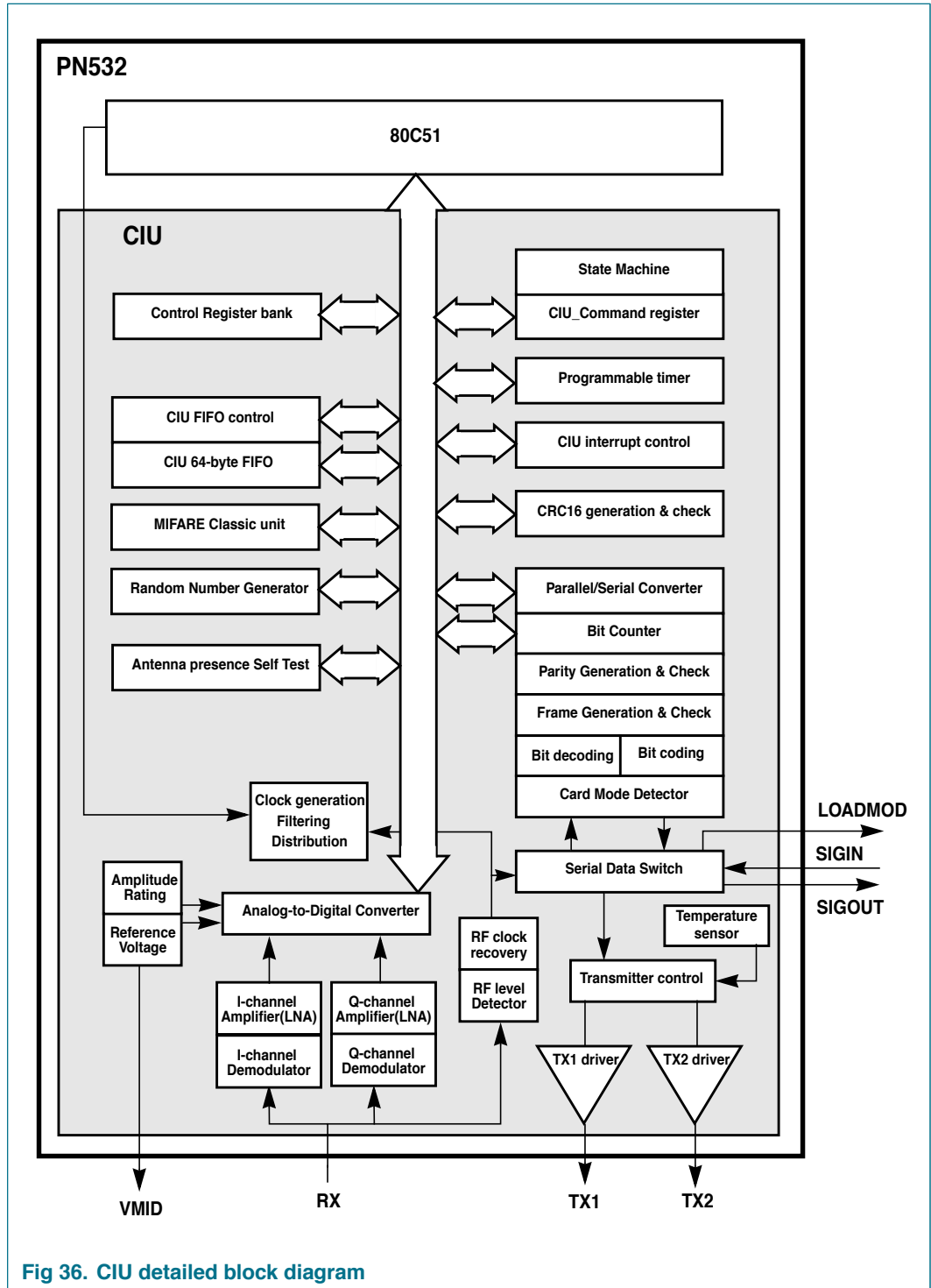

Fig 36. CIU detailed block diagram

8.6.7 Transmitter control

The signals delivered by the transmitter are on pins TX1 and pin TX2. The supply and grounds of the transmitter drivers are TVDD, TVSS1 and TVSS2.

The signals delivered are the 13.56 MHz energy carrier modulated by an envelope signal. It can be used to drive an antenna directly, using a few passive components for matching and filtering, see [Section 13 “Application information” on page 212](#). The signals on TX1 and TX2 can be configured by the register CIU_TxControl, see [Table 212 on page 159](#).

The modulation index can be set by adjusting the impedance of the drivers. The impedance of the p-driver can be configured by the registers CIU_CWGsP and CIU_ModGsP. The impedance of the n-driver can be configured by the registers CIU_GsNOn and CIU_GsNOff. Furthermore, the modulation index depends on the antenna design and tuning.

Remark: It is recommended to use a modulation index in the range of 8% for the FeliCa and NFCIP-1 communication scheme at 212 and 424 kbit/s.

The registers CIU_TxMode and CIU_TxAuto control the data rate and framing during the transmission and the setting of the antenna driver to support the different requirements at the different modes and transfer speeds.

In the following tables, these abbreviations are used:

- RF: 13.56 MHz clock derived from 27.12 MHz quartz divided by 2
- RF_n: inverted 13.56 MHz clock
- GsPMos: Conductance of the transmitter PMOS
- GsNMos: Conductance of the transmitter NMOS
- CWGsP: PMOS conductance value for Continuous Wave (see [Table 249 on page 176](#))
- ModGsP: refers to ModGsP[5:0], PMOS conductance value for Modulation (see [Table 250 on page 176](#))
- CWGsNOn: refers to CWGsP[5:0], NMOS conductance value for Continuous Wave (see [Table 247 on page 175](#))
- ModGsNOn: NMOS conductance value for Modulation when generating RF field (see [Table 247 on page 175](#))
- CWGsNOff: NMOS conductance value for Continuous Wave when no RF is generated by the PN532 itself (see [Table 239 on page 171](#))
- ModGsNOff: NMOS conductance value for modulation when load Modulation (see [Table 239 on page 171](#))

Remark: If only 1 driver is switched on, the values for ModGsNOn and CWGsNOn are used for both drivers.

Table 154. Settings for TX1

TX1 RFEn	Force 100ASK	InvTx1 RFON	InvTx1 RFOFF	Envelope	TX1	GsPMos	GsNMos	Remarks
0	X	X	0	0	0		ModGsNOff	If TX1RFEN is set to logic 0, the pin TX1 is set to logic 0 or 1 depending on InvTx1RFOFF. The bit Force 100ASK has no effect. Envelope modulates the transconductance value.
				1	0		CWGsNOff	
				1	0	1	ModGsP	
				1	1		CWGsP	
1	0	0	X	0	RF	ModGsP	ModGsNON	If TX1RFEN is set to logic 1, the RF phase of TX1 is depending on InvTx1RFON. The bit Force100ASK has effect; when Envelope is set to logic 0, TX1 is pulled to ground.
				1	RF	CWGsP	CWGsNON	
	0	1	X	0	RF_n	ModGsP	ModGsNON	
				1	RF_n	CWGsP	CWGsNON	
	1	0	X	0	0		ModGsNON	
				1	RF	CWGsP	CWGsNON	
	1	1	X	0	0		ModGsNON	
				1	RF_n	CWGsP	CWGsNON	

Table 155. Settings for TX2

TX2 RFEn	Force 100ASK	TX2CW	InvTx2 RFON	InvTx2 RFOFF	Envelope	TX2	GsPMos	GsNMos	Remarks		
0	X	0	X	0	0	0		ModGsNOff	If Tx2RFEn is set to logic 0, the pin TX2 is forced to 0 or 1 depending on the InvTx2RFOFF bit. The bit ForceASK100 has no effect. The signal Envelope modulates the transconductance value		
					1	0		CWGsNOff			
					1	0	1	ModGsP			
					1	1		CWGsP			
		1	X	0	0	0	0			CWGsNOff	When Tx2CW bit is set, the transconductance values are always CWGsP or CWGsNOff
						1	0			CWGsNOff	
						1	0	1		CWGsP	
						1	1			CWGsP	

Table 155. Settings for TX2 ...continued

TX2 RFEn	Force 100ASK	TX2CW	InvTx2 RFON	InvTx2 RFOFF	Envelope	TX2	GsPMos	GsNMos	Remarks
1	0	0	0	X	0	RF	ModGsP	ModGsNOOn	When TX2RFEn is set to logic 1 and Force100ASK set to logic 0, the phase of TX2 is depending on InvTx2RFON. If Tx2CW bit is set to logic 1, the transconductance values are always CWGsP or CWGsNOOn, independent of Envelope.
					1	RF	CWGsP	CWGsNOOn	
			1	X	0	RF_n	ModGsP	ModGsNOOn	
				1	RF_n	CWGsP	CWGsNOOn		
		1	0	X	X	RF	CWGsP	CWGsNOOn	
		1	X	X	RF_n	CWGsP	CWGsNOOn		
1	0	0	0	X	0	0		ModGsNOOn	If TX2RFEn is set to logic 1 and TX2CW to logic 0, the bit Force100ASK has effect; when Envelope is set to logic 0, TX2 is pulled to ground.
					1	RF	CWGsP	CWGsNOOn	
			1	X	0	0		ModGsNOOn	
				1	RF_n	CWGsP	CWGsNOOn		
		1	0	X	X	RF	CWGsP	CWGsNOOn	
		1	X	X	RF_n	CWGsP	CWGsNOOn		

8.6.8 RF level detector

The RF level detector is integrated to fulfill NFCIP-1 protocol requirements (e.g. RF collision avoidance).

Furthermore the RF level detector can be used to wake up the PN532 and to generate an interrupt.

The sensitivity of the RF level detector is adjustable in a 4-bit range using the bits RFLevel in register CIU_RFCfg (see [Table 245 on page 174](#)). The sensitivity itself depends on the antenna configuration and tuning.

Possible sensitivity levels at the RX pin are listed below:

Table 156. Setting of the RF level detector

VRx typical [Vpp] CIU Power-Down bit set to logic		CIU_RFCfg setting	CIU_RFCfg setting with additional amplifier see Remark
1	0		
2	1.9	1111b	
1.35	1.3	1110b	
0.95	0.9	1101b	
0.6	0.57	1100b	
0.41	0.40	1011b	
0.28	0.27	1010b	
0.17	0.17	1001b	
0.12	0.12	1000b	1xxx1111b
0.085	-	0111b ^[1]	1xxx1110b
0.055	-	0110b ^[1]	1xxx1101b
0.040	-	0101b ^[1]	1xxx1100b
-	-	0100b ^[1]	1xxx1011b ^[1]
-	-	0011b ^[1]	1xxx1010b ^[1]
-	-	0010b ^[1]	1xxx1001b ^[1]
-	-	0001b ^[1]	1xxx1000b ^[1]
-	-	0000b ^[1]	1xxx0111b ^[1]

[1] Due to noise, it is recommended not to use this setting to avoid misleading results.

To increase the sensitivity of the RF level detector an amplifier can be activated by setting the bit RFLevelAmp in register CIU_RFCfg to logic 1 (see [Table 245 on page 174](#)).

Remark: With typical antenna, lower sensitivity levels without the additional amplifier set (below 1000b) can provoke misleading results because of intrinsic noise in the environment.

Remark: For the same reasons than above, it is recommended to use the RFLevelAmp only with upper RF level settings (above 1001b).

Remark: During the CIU Power-down mode the additional amplifier of the RF level detector is automatically switched off to ensure that the power consumption is minimal.

8.6.9 Antenna presence self test

The goal of the Antenna Presence Self Test is to facilitate at assembly phase the detection of the absence of the antenna and/or antenna matching components. Such a detection is done by mean of measuring the current consumption.

Therefore the functionality is guaranteed within a restricted temperature and supply voltage range:

- VBAT voltage is above 5 V
- Ambient temperature is between 0 and 40 °C

8.6.9.1 Principle

The principle is explained with typical antenna tuning and matching components.

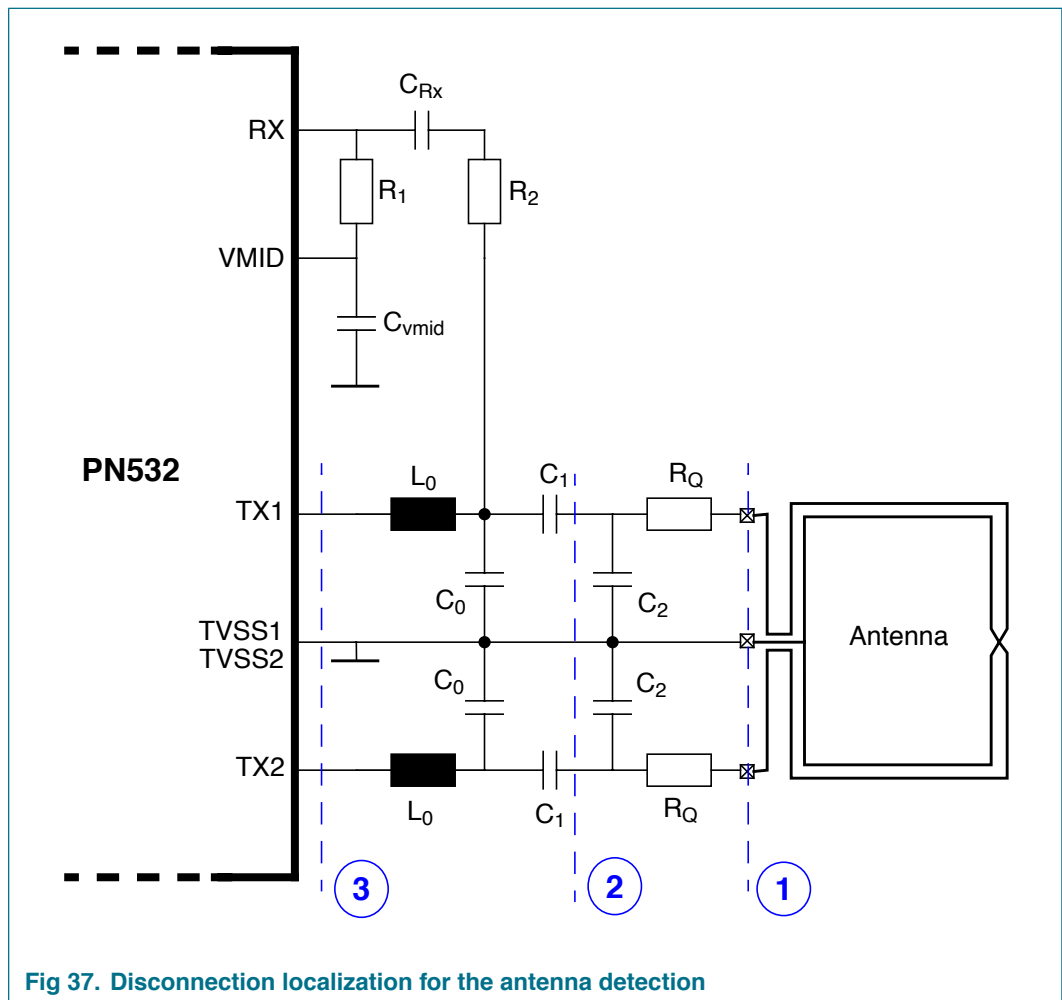

Fig 37. Disconnection localization for the antenna detection

The testing operation can be managed via a dedicated register [Table 158 on page 117](#) and requires the transmitter to be activated. When activated by asserting bit 0, the detector will monitor the current consumption through the internal low dropout voltage regulator. Any violation to the current limits will be reported via bits 7 and 6 of the register.

Several levels of detection can be programmed through the register to offer a large panel of compatibility to different type of antennas. The high current threshold can be programmed from 40 mA to 150 mA with 15 mA steps (total current consumption of the IC). The low current threshold can be programmed from 5mA to 35 mA with 10 mA step (total current consumption of the IC).

There is no dedicated pin for the output of the detector. The result of the detection is to be read out from the antenna test register.

- Cases 1 and 2: If the antenna and/or the tuning network are not connected, the TVDD current is higher than the nominal one. The antenna detector detects this higher consumption and the andet_up bit in andet_control register is set to high
- Case 3: If the EMC filter is not correctly connected, the current within TVDD is lower than the nominal one. The antenna detector detects this lower consumption and the andet_bot bit in andet_control register is set to high.

To have this functionality working properly it is needed to have the transmitter generating some RF in the antenna.

8.6.9.2 Antenna presence detector register

Table 157. andet_control register (address 610Ch) bit allocation

Bit	7	6	5	4	3	2	1	0
Symbol	andet_bot	andet_up	andet_ithl[1:0]		andet_ithh[2:0]			andet_en
Reset	0	0	0	0	0	0	0	0
Access	R	R	R/W	R/W	R/W	R/W	R/W	R/W

Table 158. Description of andet_control bits

Bit	Symbol	Description
7	andet_bot	A too low power consumption has been detected
6	andet_up	A too high power consumption has been detected
5 to 4	andet_ithl[1:0]	Set the low current consumption threshold to be detected Define the overcurrent threshold 00: do not use 01: do not use 10: 25 mA 11: 35 mA
3 to 1	andet_ithh[2:0]	Set the high current consumption threshold to be detected 000: 45 mA 001: 60 mA 010: 75 mA 011: 90 mA 100: 105 mA 101: 120 mA 110: 130 mA 111: 150 mA
0	andet_en	Enable the detection of the antenna presence detector functionality.

8.6.10 Random generator

The random generator is used to generate various random number needed for the NFCIP-1 protocol, as well as for MIFARE security.

It can also be used for test purpose, by generating random data through the field.

Table 159. Data_rng register (address 6105h) bit allocation

Bit	7	6	5	4	3	2	1	0
Symbol	data_rng							
Reset	X	X	X	X	X	X	X	X
Access	R/W	R/W	R/W	R/W	R/W	R/W	R/W	R/W

Table 160. Description of Data_rng bits

Bit	Symbol	Description
7 to 0	data_rng	Random number data register.

The Control_switch_rng register can also be used to control the behavior of the SVDD switch.

Table 161. Control_switch_rng register (address 6106h) bit allocation

Bit	7	6	5	4	3	2	1	0
Symbol	-	hide_svdd_sig	sic_switch_overload	sic_switch_en	-	cpu_need_rng	random_dataready	-
Reset	0	1	0	0	0	0	0	1
Access	R	R/W	R	R/W	R	R/W	R/W	R

Table 162. Description of Control_switch_rng bits

Bit	Symbol	Description
7	-	Reserved.
6	hide_svdd_sig	Configure the internal state of SIGIN and P34 in an idle state. This bit can be used to avoid spikes on SIGIN and P34 when the SVDD switch becomes enabled or disabled. When set to logic 0, the internal state of SIGIN and P34 signals are driven by respectively the pads SIGIN and P34. When set to logic 1, the internal state of SIGIN is fixed to 0 and the internal state of P34 is fixed set to logic 1.
5	sic_switch_overload	State of the current limitation of the SVDD switch. When set to logic 0, it indicates that the current consumption into the SVDD switch does no exceed the limit. When set to logic 1, the current limitation of the SVDD switch is activated by the switch.
4	sic_switch_en	Enable of the SVDD switch. When set to logic 0, the SVDD switch is disabled and the SVDD output power is tied to the ground. When set to logic 1, the SVDD switch is enabled and the SVDD output deliver power to the secure IC and to the internal pads (SIGIN, SIGOUT and P34).
3	-	Reserved

Table 162. Description of Control_switch_rng bits ...continued

Bit	Symbol	Description
2	cpu_need_rng	Force the random number generator in running mode. When set to logic 0, the random number generator is under control of the CIU. When set to logic 1, the random number generator is forced to run.
1	random_dataready	Indicates availability of random number. When set to logic 1, it indicates that a new random number is available. It is automatically set to logic 0 when the register data_rng is read.
0	-	Reserved.

8.6.11 Data mode detector

The data mode detector is able to detect received signals according to the ISO/IEC 14443A/MIFARE, FeliCa or NFCIP-1 schemes and the standard baud rates for 106 kbit/s, 212 kbit/s and 424 kbit/s in order to prepare the internal receiver in a fast and convenient way for further data processing.

The data mode detector can only be activated by the AutoColl command (see [Section 8.6.20.12 “AutoColl command” on page 136](#)). The mode detector is reset, when no external RF field is detected by the RF level detector.

The data mode detector could be switched off during the Autocoll command by setting the bit ModeDetOff in the register Mode to logic 1 (see [Table 207 on page 156](#)).

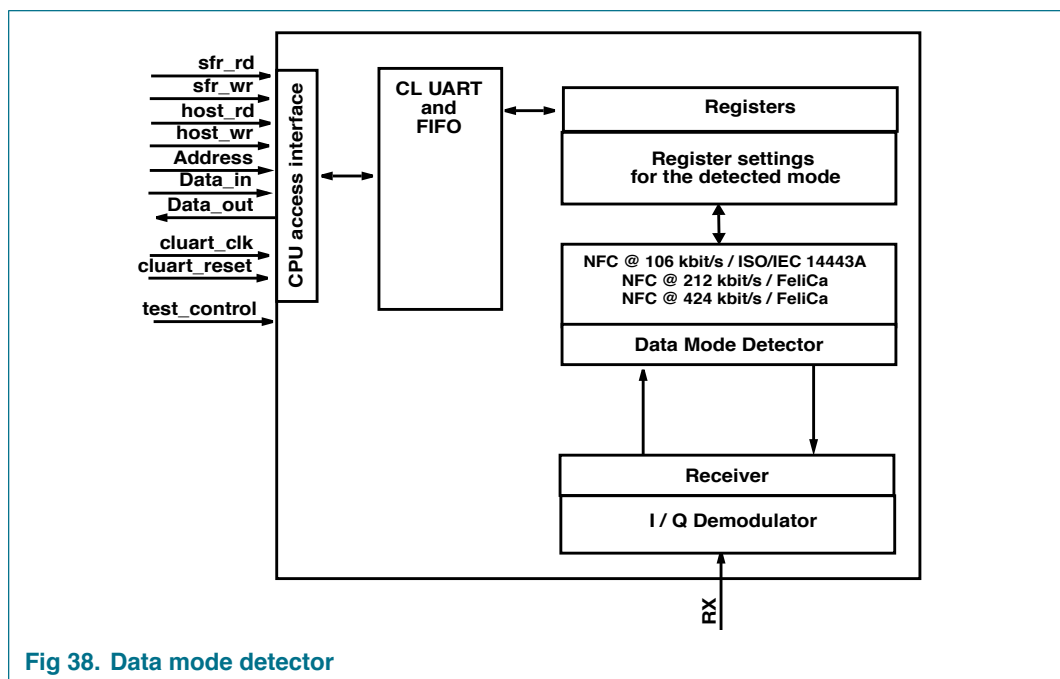

Fig 38. Data mode detector

8.6.12 Serial data switch

Two main blocks are implemented in the CIU. A digital block comprising state machines, coder and decoder logic and an analog block with the modulator and antenna drivers, receiver and amplifier. The Serial Data Switch is the interface between these two blocks.

The Serial Data Switch can route the interfacing signals to the pins SIGIN and SIGOUT.

SIGOUT and SIGIN are mainly used to enable the NFC-WI/S²C interface in the secure IC to emulate card functionality with the PN532. SIGIN is capable of processing a digital signal on transfer speeds above 424 kbit/s. SIGOUT pin can also provide a digital signal that can be used with an additional external circuit to generate transfer speeds at 106 kbit/s, 212 kbit/s, 424 kbit/s and above.

Load modulation is usually performed internally by the CIU, via TX1 and TX2. However, it is possible to use LOADMOD to drive an external circuitry performing load modulation at the antenna (see optional circuitry of [Figure 51 on page 212](#)).

The Serial Data Switch is controlled by the registers CIU_TxSel (see [Table 217 on page 161](#)) and CIU_RxSel (see [Table 219 on page 162](#)).

8.6.12.1 Serial data switch for driver and loadmod

The following figure shows the serial data switch for pins TX1 and TX2.

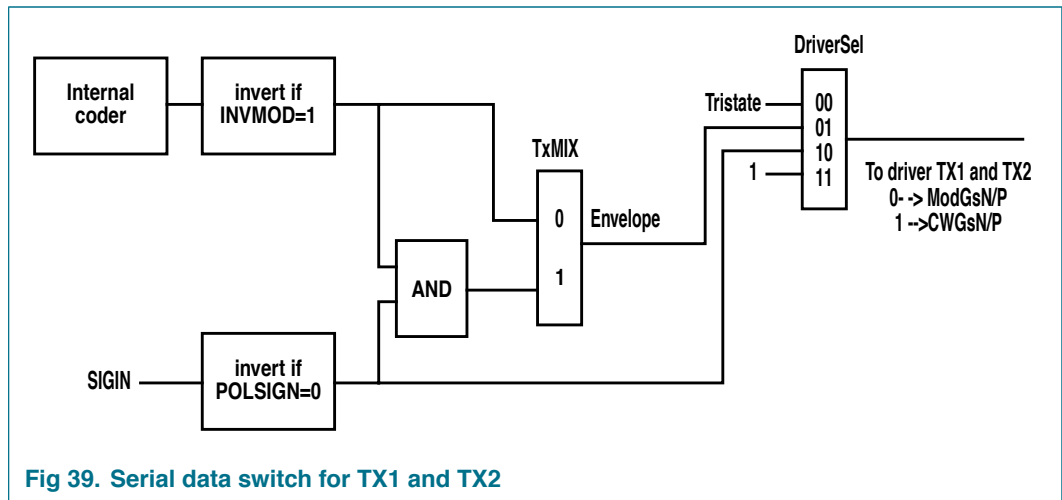
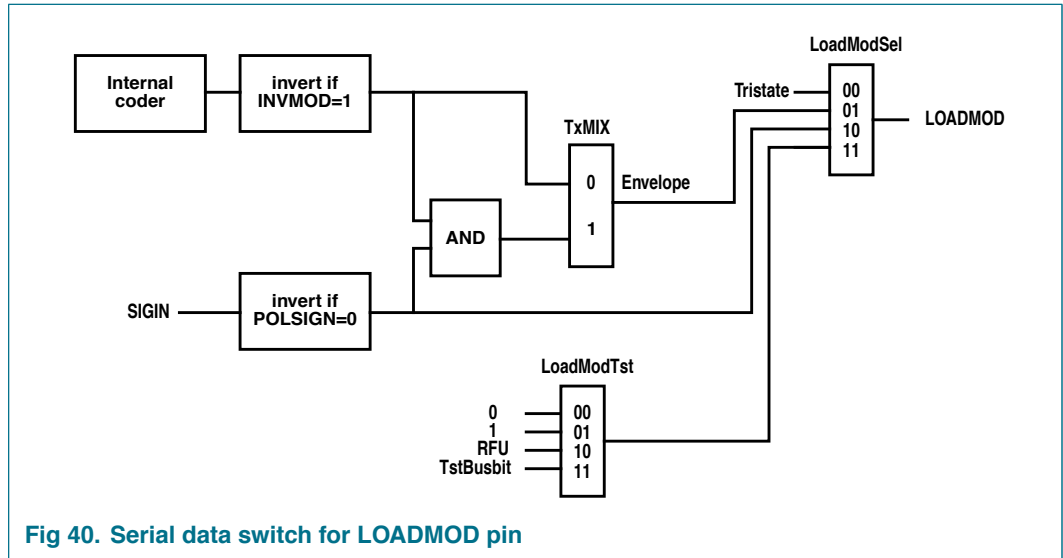

Fig 39. Serial data switch for TX1 and TX2

SIGIN is in general only used for secure IC communication. If TxMix is set to logic 1 (see [Table 217 on page 161](#)), the driver pins are simultaneously controlled by SIGIN and the internal coder.

The following figure shows the serial data switch for the LOADMOD pin.



8.6.13 NFC-WI/S²C interface support

The NFC-WI/S²C provides the possibility to directly connect a secure IC to the PN532 in order to act as a contactless smart card IC via the PN532. The interfacing signals can be routed to the pins SIGIN and SIGOUT. SIGIN can receive either a digital FeliCa or digital ISO/IEC 14443A signal sent by the secure IC. The SIGOUT pin can provide a digital signal and a clock to communicate to the secure IC. A secure IC can be a smart card IC provided by NXP Semiconductors.

The PN532 generates the supply SVDD to the secure IC. The pins SIGIN and SIGOUT are referred to this supply, as well as pin P34 / SIC_CLK, which can be used as an extra pin for the connection to a secure IC.

The following figure outlines the supported communication flows via the PN532 to the secure core IC.

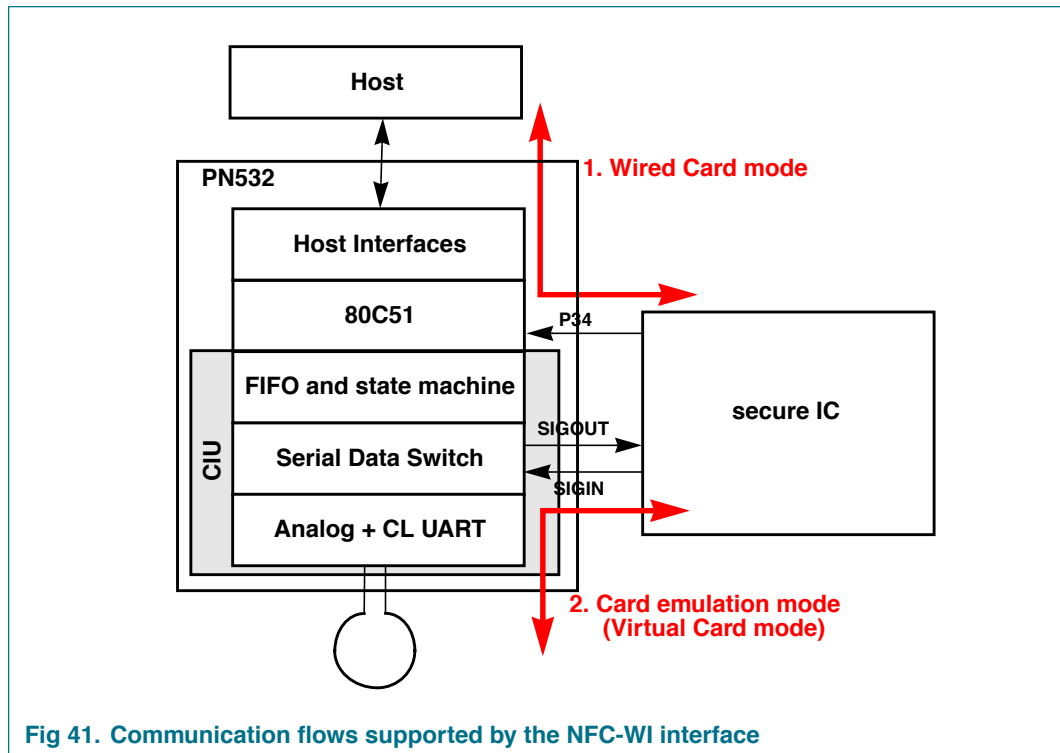

Fig 41. Communication flows supported by the NFC-WI interface

Configured in the Wired Card mode the host controller can directly communicate to the secure IC via SIGIN/SIGOUT. In this mode the PN532 generates the RF clock and performs the communication on the SIGOUT line. To enable the Wired Card mode the clock has to be derived by the internal oscillator of the PN532 (see bits sic_clock_sel in [Table 265 on page 180.](#))

Configured in Card emulation mode the secure IC can act as contactless smart card IC via the PN532. In this mode the signal on the SIGOUT line is provided by the RF field of the external Reader/Writer. To enable the Virtual Card mode the clock derived by the external RF field has to be used.

The configuration of the NFC-WI/S²C interface differs for the FeliCa and MIFARE scheme as outlined in the following chapters.

8.6.13.1 Signal shape for FeliCa NFC-WI/S²C interface support

The FeliCa secure IC is connected to the PN532 via the pins SIGOUT and SIGIN.

The signal at SIGOUT contains the information of the 13.56 MHz clock and the digitized demodulated signal. The clock and the demodulated signal are combined by using the logical function exclusive OR; XOR.

To ensure that this signal is free of spikes, the demodulated signal is digitally filtered first. The time delay for the digital filtering is in the range of one bit length. The demodulated signal changes only at a positive edge of the clock.

The register CIU_TxSel (see [Table 217 on page 161](#)) controls the setting at SIGOUT

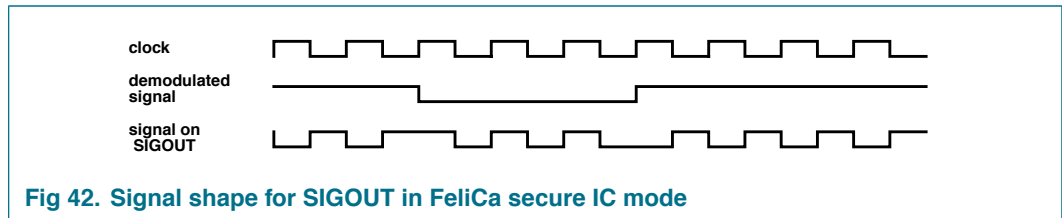

Fig 42. Signal shape for SIGOUT in FeliCa secure IC mode

Remark: The PN532 differs from the ECMA 373 specification, by the fact that when in FeliCa card emulation mode, the PN532 does send preamble bytes at 212kbps on SIGOUT as soon as the PN532 detects RF field.

Remark: In FeliCa card emulation mode, when the PN532 mode detector is activated, the data sent on SIGOUT are clocked at the received data rate only after the SYNC bytes are received. If per default the FeliCa card emulation mode is expected at 212kbps, the 424kbps may need specific implementation at application level: the PN532 will sent beginning of first received frame (preamble+SYNC bytes) at 212kbps.

Remark: To properly work in FeliCa wired card mode, the SIGIN signal generated by the FeliCa secure element must be synchronous with the received SIGOUT bit clock, and the bit RCVOFF in the register 6331h (or SFR register D1h) must be set to logic level 1. The phase relationship of the SIGIN and SIGOUT bit clocks must respect a modulo[4] 13.56MHz clock cycles.

The response from the FeliCa secure IC is transferred from SIGIN directly to the antenna driver. The modulation is done according to the register setting of the antenna drivers.

The 13.56MHz clock can be switched to P34 / SIC_CLK (see sic_clk_p34_en bit in [Table 177 on page 144](#)).

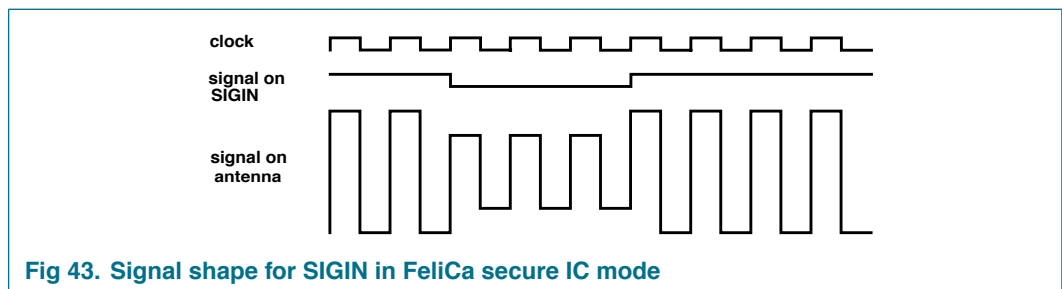

Fig 43. Signal shape for SIGIN in FeliCa secure IC mode

Remark: The signal on antenna is shown in principle only. This signal is sinusoidal. The clock for SIGIN is the same as the clock for SIGOUT.

8.6.13.2 Signal shape for ISO/IEC14443A and MIFARE NFC-WI/S²C support

The secure IC, e.g. the SmartMX is connected to the PN532 via the pins SIGOUT, SIGIN and P34 / SIC_CLK.

The signal at SIGOUT is a digital 13.56 MHz Miller coded signal between PVSS and SVDD. It is either derived from the external 13.56 MHz carrier signal when in Virtual Card Mode or internally generated when in Wired Card mode.

The register CIU_TxSel controls the setting at SIGOUT.

Note: The clock settings for the Wired Card mode and the Virtual Card mode differ. Refer to the description of the bit SicClockSel in register CIU_TestSel1.

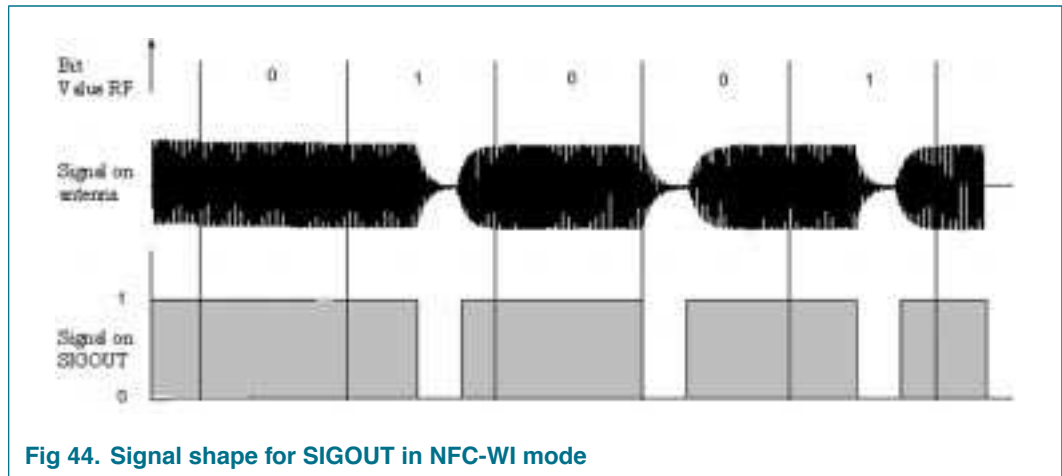

Fig 44. Signal shape for SIGOUT in NFC-WI mode

The signal at SIGIN is a digital Manchester coded signal compliant with ISO/IEC 14443A with a subcarrier frequency of 847.5 kHz generated by the secure IC.

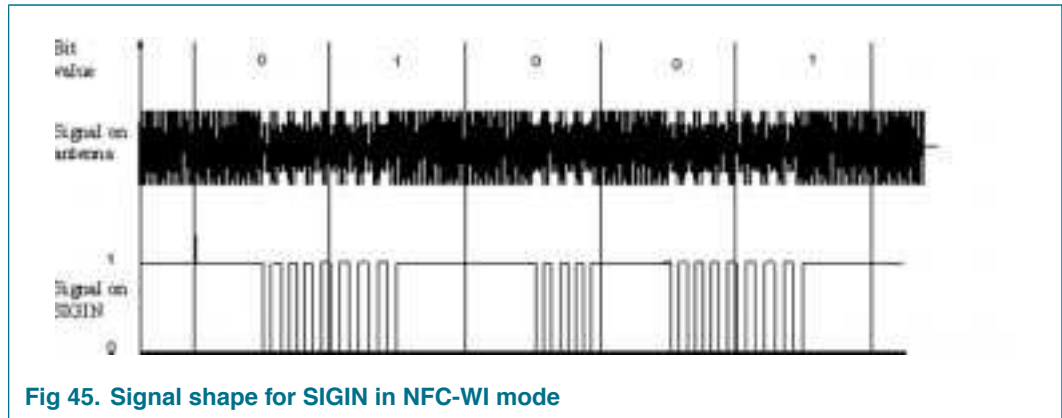

Fig 45. Signal shape for SIGIN in NFC-WI mode

8.6.13.3 NFC-WI/S²C initiator mode

The PN532 includes 2 counters of 127 and 31, with digital filtering, to enable activation from the secure IC (ACT_REQ_Si), or the command to go from data to command mode (ESC_REQ).

Table 163. NFC_WI_control register (address 610Eh) bit allocation

Bit	7	6	5	4	3	2	1	0
Symbol	-	-	-	-	nfc_wi_status	-	nfc_wi_en_act_req_im	nfc_wi_en_clk
Reset	0	0	0	0	0	0	0	0
Access	R	R	R	R	R	R/W	R/W	R/W

Table 164. Description of NFC_WI_control bits

Bit	Symbol	Description
7 to 4	-	Reserved.
3	nfc_wi_status	Indicates a NFC-WI counter has reached its limit. Set to logic 1, when the counter has reached its limit. It can also be used as an interrupt for the 80C51 if the IE0_6 bit is set to logic 1 (see Table 10 on page 17).
2	-	Reserved.
1	nfc_wi_en_act_req_im	Selection of the NFC-WI counter. This bit is used to select the 31 or 127 counter. When set to logic 0, the 31 counter is selected. When set to logic 1, the 127 counter is selected.
0	nfc_wi_en_clk	Enable the NFC-WI counters on SIGIN. When set to logic 1, the counters can run and count the clock cycles within 2 and 12 MHz.

8.6.14 Hardware support for FeliCa and NFC polling

8.6.14.1 Polling sequence functionality for initiator

1. Timer: The CIU has a timer, which can be programmed to generate an interrupt at the end of each timeslot, or if required at the end of the last timeslot only.
2. The receiver can be configured to receive frames continuously. The receiver is ready to receive immediately after the last frame has been transmitted. This mode is activated by setting to logic 1 the bit RxMultiple in the register CIU_RxMode. It has to be set to logic 0 by firmware.
3. The CIU adds one byte at the end of every received frame, before it is transferred into the FIFO buffer. This byte indicates whether the received frame is correct (see register Err). The first byte of each frame contains the length byte of the frame.
4. The length of one frame is 18 or 20 bytes (+1 byte error Info). The size of the FIFO is 64 bytes. This means 3 frames can be stored in the FIFO at the same time. If more than 3 frames are expected, the 80C51 has to read out data from the FIFO, before the FIFO is filled completely. In the case that the FIFO overflows, data is lost. (See error flag BufferOvfl).

8.6.14.2 Polling sequence functionality for target

1. The 80C51 has to configure the CIU with the correct polling response parameters for the Polling command.
2. To activate the automatic polling in target mode, the AutoColl Command has to be activated.
3. The CIU receives the polling command send out by an initiator and answers with the polling response. The timeslot is selected automatically (The timeslot itself is randomly generated, but in the range 0 to TSN, which is defined by the polling command). The CIU compares the system code, stored in byte 17 and 18 of the Config Command with the system code received with the polling command by an initiator. If the system code is equal, the CIU answers according to the configured polling response. The system code FF(hex) acts as a wildcard for the system code bytes (i.e. a target of a system code 1234(hex) answers to the polling command with one of the following system codes 1234(hex), 12FF(hex), FF34 (hex) or FFFF(hex)). If the system code does not match no answer is sent back by the PN532. If a valid command, which is not a Polling command, is received by the CIU, no answer is sent back and the command AutoColl is stopped. The received frame is stored in the FIFO.

8.6.14.3 Additional hardware support for FeliCa and NFC

Additionally to the polling sequence support for the FeliCa mode, the PN532 supports the check of the LEN-byte.

The received LEN-byte is checked by the registers CIU_FeINFC1 and CIU_FeINFC2:

DataLenMin in register CIU_FeINFC1 defines the minimum length of the accepted frame length. This register is 6 bits long. Each value represents a length of 4.

DataLenMax in register CIU_FeINFC2 defines the maximum length of the accepted frame. This register is 6 bits long. Each value represents a length of 4. If set to logic 0 this limit is switched off. If the length is not in the supposed area, the packed is not transferred to the FIFO and receiving is kept active.

Example 1:

- DataLenMin = 4
 - The length shall be greater or equal 16.
- DataLenMax = 5
 - The length shall be smaller than 20. Valid area: 16, 17, 18, 19

Example 2:

- DataLenMin = 9
 - The length shall be greater or equal 36.
- DataLenMax = 0
 - The length shall be smaller than 256. Valid area: 36 to 255

8.6.15 CRC co-processor

The CRC preset value of the CRC co-processor can be configured to 0000h, 6363h, A671h or FFFFh depending of the bits CRCPreset in the register Mode. This is only valid when using CalcCRC command (see [Section 8.6.20.7 “CalcCRC command” on page 134](#))

During a communication, the preset value of the CRC coprocessor is set according to the bits CIU_RxMode and CIU_TxMode.

The CRC polynomial for the 16-bit CRC is fixed to $x^{16} + x^{12} + x^5 + 1$.

The CRC co-processor is configurable to handle the different MSB and LSB requirements for the different protocols. The bit MSBFirst in the register CIU_Mode indicates that the data will be loaded with MSB first

The registers CRCResult-Hi and CRCResult-Lo indicate the result of the CRC calculation.

8.6.16 FIFO buffer

An 64*8 bits FIFO buffer is implemented in the CIU. It buffers the input and output data stream between the 80C51 and the internal state machine of the CIU. Thus, it is possible to handle data streams with lengths of up to 64 bytes without taking timing constraints into account.

8.6.16.1 Accessing the FIFO buffer

The FIFO-buffer input and output data bus is connected to the register CIU_FIFOData. Writing to this register stores one byte in the FIFO-buffer and increments the internal FIFO-buffer write-pointer. Reading from this register shows the FIFO-buffer contents stored at the FIFO-buffer read-pointer and decrements the FIFO-buffer read-pointer. The distance between the write- and read-pointer can be obtained by reading the register CIU_FIFOLevel.

When the 80C51 starts a command, the CIU may, while the command is in progress, access the FIFO-buffer according to that command. Physically only one FIFO-buffer is implemented, which can be used in input- and output direction. Therefore the 80C51 has to take care, not to access the FIFO-buffer in an unintended way.

8.6.16.2 Controlling the FIFO buffer

Besides writing to and reading from the FIFO-buffer, the FIFO-buffer pointers might be reset by setting the bit FlushBuffer in the register CIU_FIFOLevel. Consequently, the FIFOLevel[6:0] bits are set to logic 0, the bit BufferOvfl in the register CIU_Error is set to logic 0, the actually stored bytes are not accessible anymore and the FIFO-buffer can be filled with another 64 bytes again.

8.6.16.3 Status information about the FIFO buffer

The 80C51 may obtain the following data about the FIFO-buffers status:

- Number of bytes already stored in the FIFO-buffer: FIFOLevel[6:0] in register CIU_FIFOLevel
- Warning, that the FIFO-buffer is quite full: HiAlert in register CIU_Status1
- Warning, that the FIFO-buffer is quite empty: LoAlert in register CIU_Status1
- Indication, that bytes were written to the FIFO-buffer although it was already full: BufferOvfl in register CIU_Error.

BufferOvfl can be set to logic 0 only by setting to logic 1 bit FlushBuffer in the register CIU_FIFOLevel.

The CIU can generate an interrupt signal

- If LoAlertIEn in register CIU_CommIEn is set to logic 1, it will set to logic 1 CIU_IRQ_0 in the register CIU_Status1, when LoAlert in the same register changes to logic 1.
- If HiAlertIEN in register CIU_CommIEn is set to logic 1, it will set to logic 1 CIU_IRQ_0 in the register CIU_Status1, when HiAlert in the same register changes to logic 1.

The flag HiAlert is set to logic 1 if only WaterLevel[5:0] bits (as set in register CIU_WaterLevel) or less can be stored in the FIFO-buffer. It is generated by the following equation:

$$HiAlert = (64 - FIFOLength) \leq WaterLevel$$

The flag LoAlert is set to logic 1 if WaterLevel[5:0] bits (as set in register CIU_WaterLevel) or less are actually stored in the FIFO-buffer. It is generated by the following equation:

$$LoAlert = FIFOLength \leq WaterLevel$$

8.6.17 CIU_timer

A timer unit is implemented in the CIU: CIU_timer. The 80C51 use CIU_timer to manage timing relevant tasks for contactless communication. CIU_timer may be used in one of the following configurations:

- Timeout-Counter
- Watch-Dog Counter
- Stop Watch
- Programmable One-Shot
- Periodical Trigger

CIU_timer can be used to measure the time interval between two events or to indicate that a specific event occurred after a specific time. CIU_timer can be triggered by events which will be explained in the following, but it does not itself influence any internal event (e.g. A timeout during data reception does not influence the reception process automatically). Furthermore, several timer related bits are set and these bits can be used to generate an interrupt.

CIU_timer has a input clock of 6.78 MHz (derived from the 27.12 MHz quartz). CIU_timer consists of 2 stages: 1 prescaler and 1 counter.

The prescaler is a 12 bits counter. The reload value for the prescaler can be defined between 0 and 4095 in register CIU_TMode and CIU_TPrescaler. This decimal value is called TPrescaler.

The reload value TReloadVal for the counter is defined with 16 bits in a range from 0 to 65535 in the registers CIU_TReloadVal_Lo and CIU_TReloadVal_Hi.

The current value of CIU_timer is indicated by the registers CIU_TCounterVal_lo and CIU_TCounterVal_hi.

If the counter reaches 0 an interrupt will be generated automatically indicated by setting the TimerIRq flag in the register CommonIRq. If enabled, it will set to logic 1 CIU_IRQ_1 in the register CIU_Status1. TimerIRq flag can be set to logic 1 or to logic 0 by the 80C51. Depending on the configuration, CIU_timer will stop at 0 or restart with the value of the registers CIU_TReloadVal_Lo and CIU_TReloadVal_Hi.

Status of CIU_timer is indicated by the bit TRunning in the register CIU_Status1.

CIU_timer can be manually started by TStartNow in register Control or manually stopped by TStopNow in register Control.

Furthermore CIU_timer can be activated automatically by setting the bit TAuto in the register CIU_TMode to fulfill dedicated protocol requirements automatically.

The time delay of a timer stage is the reload value +1.

Maximum time:

$$TPrescaler = 4095, TReloadVal = 65535 \Rightarrow 4096 * 65536 / 6.78 \text{ MHz} = 39.59 \text{ s}$$

Example:

To indicate 100 ms it is required to count 678 clock cycles. This means the value for TPrescaler has to be set to TPrescaler = 677. The timer has now an input clock of 100 us. The timer can count up to 65535 timeslots of 100 ms.

8.6.18 Interrupt request system

The CIU indicates certain events by setting interrupt bits in the register CIU_Status1 and, in addition it will set to logic 1 CIU_IRQ_1 or CIU_IRQ_0. If this interrupt is enabled (see [Table 12 on page 18](#)) the 80C51 will be interrupted. This allows the implementation of efficient interrupt-driven firmware.

8.6.18.1 Interrupt sources

The following table shows the integrated interrupt flags, the corresponding source and the condition for its activation.

The interrupt flag TimerIRq in the register CIU_Commlrq indicates an interrupt set by the timer unit. The setting is done when the timer decrements from logic 1 down to logic 0.

The TxIRq bit in the register CIU_Commlrq indicates that the transmitter has finished. If the state changes from sending data to transmitting the end of frame pattern, the transmitter unit sets automatically the interrupt bit to logic 1.

The CRC coprocessor sets the flag CRCIRq in the register CIU_Divlrq after having processed all data from the FIFO buffer. This is indicated by the flag CRCReady set to logic 1.

The RxIRq flag in the register CIU_Commlrq indicates an interrupt when the end of the received data is detected.

The flag IdleIRq in the register CIU_Commlrq is set to logic 1 if a command finishes and the content of the CIU_Command register changes to idle.

The flag HiAlertIRq in the register CIU_Commlrq is set to logic 1 if the HiAlert bit is set to logic 1, that means the Contactless FIFO buffer has reached the level indicated by the bits WaterLevel[5:0].

The flag LoAlertIRq in the register CIU_Commlrq is set to logic 1 if the LoAlert bit is set to logic 1, that means the Contactless FIFO buffer has reached the level indicated by the bits WaterLevel[5:0].

The flag RFOnIRq in the register CIU_Divlrq is set to logic 1, when the RF level detector detects an external RF field.

The flag RFOffIRq in the register CIU_Divlrq is set to logic 1, when a present external RF field is switched off.

The flag ErrIRq in the register CIU_Commlrq indicates an error detected by the CIU during sending or receiving. This is indicated by any bit set to logic 1 in register CIU_Error.

The flag ModeIRq in the register CIU_Divlrq indicates that the data mode detector has detected the current mode.

These flags are summarized with 2 interrupt bits within the register CIU_Status1:

- the high priority interrupt sources are summarized with CIU_IRQ_0.
- the low priority interrupt sources are summarized with CIU_IRQ_1.

See the register [Table 190 on page 150](#).

Table 165. High priority interrupt sources (CIU_IRQ_0)

Interrupt Flag	Interrupt source	Set automatically, WHEN
TxIRq	Transmitter	a transmitted data stream ends
RxIRq	Receiver	a received data stream ends
HiAlertIRq	FIFO-buffer	the FIFO-buffer is getting full
LoAlertIRq	FIFO-buffer	the FIFO-buffer is getting empty

Table 166. Low priority interrupt sources (CIU_IRQ_1)

Interrupt Flag	Interrupt source	Set automatically, WHEN
TimerIRq	Timer Unit	the timer counts from 1 to 0
CRCIRq	CRC-Coprocessor	all data from the FIFO buffer have been processed
IdleIRq	CIU_Command Register	a command execution finishes
RFOnIRq	RF Level Detector	an external RF field is detected
RFOffIRq	RF Level Detector	a present external RF field is switched off
ErrIRq	CIU	an error is detected
ModeIRq	data mode detector	the mode has been detected

8.6.19 CIU Power Reduction Modes

8.6.19.1 Hard-Power-Down

A Hard-Power-Down is enabled when RSTPD_N is low. None of the CIU blocks are running, even the RF level detector.

8.6.19.2 CIU Power-down

The CIU Power-down mode is entered immediately by setting the Power-down bit in the register CIU_Command. All CIU blocks are switched off, except the 27.12 MHz oscillator and the RF level detector.

All registers and the FIFO will keep the content during CIU Power-down.

If the bit AutoWakeUp in the register CIU_TxAuto is set and an external RF field is detected, the CIU Power-down mode is left automatically.

After setting bit Power-down to logic 0 in the register CIU_Command, it needs 1024 clocks cycle until the CIU Power-down mode is left indicated by the Power-down bit itself. Setting it to logic 0 does not immediately set it to logic 0. It is automatically set to logic 0 by the CIU when the CIU Power-down mode is left.

When in CIU Power-down mode and DriverSel[1:0] is not set to 00b (see [Table 217 on page 161](#)), to ensure a minimum impedance at the transmitter outputs, the CWGsNOn[3], CWGsNOff[3], ModGsNOn[3], ModGsNOff[3], CWGsP[5], ModGsP[5] bits are set to logic 1, but it is not readable in the registers.

8.6.19.3 Transmitter Power-down

The Transmitter Power-down mode switches off the internal antenna drivers to turn off the RF field by setting the bits Tx1RFEn and Tx2RFEn in the register CIU_TxControl to logic 0. The receiver is still switched on, meaning the CIU can be accessed by a second NFC device as a NFCIP-1 target.

Note: In case the bit InitialRFOn has been set to logic 1, when the drivers were already switched on, it is needed either to set InitialRFOn to logic 0, before setting the bits Tx1RFEn and Tx2RFEn in the register CIU_TxControl to logic 0, or to set also the bits Tx1RFAutoEn and Tx2RFAutoEn in the register CIU_TxAuto to logic 0.

8.6.20 CIU command set

8.6.20.1 General description

The CIU behavior is determined by an internal state machine capable to perform a certain set of commands. Writing the according command code to the CIU_Command register starts the commands.

Arguments and/or data necessary to process a command are mainly exchanged via the FIFO buffer.

8.6.20.2 General behavior

- Each command, that needs a data stream (or data byte stream) as input will immediately process the data it finds in the FIFO buffer. An exception to this rule is the Transceive command. Using this command the transmission is started with the StartSend bit in CIU_BitFraming register.
- Each command that needs a certain number of arguments will start processing only when it has received the correct number of arguments via the FIFO buffer.
- The FIFO buffer is not cleared automatically at command start. Therefore, it is also possible to write the command arguments and/or the data bytes into the FIFO buffer and start the command afterwards.
- Each command may be interrupted by the 80C51 by writing a new command code into the CIU_Command register e.g.: the Idle command.

8.6.20.3 Commands overview

Table 167. Command overview

Command	Command code	Action
Idle	0000	No action; cancels current command execution.
Config	0001	Configures the CIU for FeliCa, MIFARE and NFCIP-1 communication.
Generate RandomID	0010	Generates 10-byte random ID number
CalcCRC	0011	Activates the CRC co-processor or perform self-test.
Transmit	0100	Transmits data from the FIFO buffer.
NoCmdChange	0111	No command change. This command can be used to modify different bits in the CIU_Command register without touching the command. e.g. Power-down bit.
Receive	1000	Activates the receiver circuitry.
SelfTest	1001	Activates the self-test. Not described in this chapter.
Transceive	1100	If bit Initiator in the register CIU_Control is set to logic 1: Transmits data from FIFO buffer to the antenna and activates automatically the receiver after transmission is finished. If bit Initiator in the register CIU_Control is set to logic 0: Receives data from antenna and activates automatically the transmitter after reception.
AutoColl	1101	Handles FeliCa polling (Card operating mode only) and MIFARE anticollision (Card operating mode only)
MFAuthent	1110	Performs the MIFARE 1 KB or MIFARE 4 KB emulation authentication in MIFARE Reader/Writer mode only.
Soft Reset	1111	Resets the CIU.

8.6.20.4 Idle command

The CIU is in idle mode. This command is also used to terminate the actual command.

8.6.20.5 Config command

To configure the automatic MIFARE Anticollision, FeliCa Polling and NFCID3, the data used for these transactions have to be stored internally. All the following data have to be written to the FIFO in this order:

- SENS_RES (2 bytes): in order byte0, byte1
- NFCID1 (3 Bytes): in order byte0, byte1, byte 2; the first NFCID1 byte is fixed to 08h and the check byte is calculated automatically
- SEL_RES (1 byte)
- Polling response (2 bytes (shall be 01h, FEh)+ 6 bytes NFCID2 + 8 bytes Pad + 2 bytes system code)
- NFCID3 (1 byte)

In total 25 bytes which are transferred into an internal buffer with the Config command.

The complete NFCID3 is 10 bytes long and consist of the 3 NFCID1 bytes, the 6 NFCID2 bytes and the NFCID3 byte listed above.

To read out this configuration (after it has been loaded), the command Config with an empty FIFO buffer has to be started. In this case the 25 bytes are transferred from the internal buffer to the FIFO.

The CIU has to be configured after each power up, before using the automatic Anticollision/Polling function (AutoColl command). During a Hard-Power-Down (RSTPD_N set to logic 0) this configuration remains unchanged.

This command terminates automatically when finished and the active command is Idle.

8.6.20.6 Generate RandomID command

This command generates a 10-byte random number stored in the internal 25 bytes buffer and overwrites the 10 NFCID3 bytes. This random number might be used for fast generation of all necessary ID bytes for the automatic Anticollision / Polling function.

Note: To configure the CIU, Config command has to be used first.

This command terminates automatically when finished and the active command is Idle

8.6.20.7 CalcCRC command

The content of the FIFO is transferred to the CRC co-processor and a CRC calculation is started. The result is stored in the CRCResult register. The CRC calculation is not limited to a dedicated number of bytes. The calculation is not stopped when the FIFO gets empty during the data stream. The next byte written to the FIFO is added to the calculation.

The preset value of the CRC is defined by the CRCPreset bits of the register CIU_Mode, and the chosen value is loaded to the CRC co-processor when the command is started.

This command has to be terminated by firmware by writing any command to the CIU_Command register e.g. the Idle command.

If SelfTest in register CIU_AutoTest is set to logic 1, the CRC co-processor is in Self Test mode and performs a digital self-test. The result of the self-test is written in the FIFO.

8.6.20.8 Transmit command

The content of the FIFO is transmitted immediately after starting the command. Before transmitting FIFO content, all relevant register settings have to be set to transmit data in the selected mode.

This command terminates automatically when the FIFO gets empty and the active command is Idle. It can be terminated by any other command written to the CIU_Command register.

8.6.20.9 NoCmdChange command

This command does not influence any ongoing command in the CIU_Command register. It can be used to manipulate any bit except the command bits in the CIU_Command register, e.g. the bits RcvOff or Power-down.

8.6.20.10 Receive command

The CIU activates the receiver path and waits for any data stream to be received. The correct settings for the expected mode have to be set before starting this command.

This command terminates automatically when the reception ends and the active command is Idle.

In case of data rates at 212 kbps or 424 kbps with NFC or FeliCa framing, the reception ends when the number of bytes indicated by the LEN byte (received) are received. If less bytes than indicated by LEN are received from the RF, the CIU will sample noise to add the missing bytes. If more bytes than indicated by LEN are received from the RF, the last bytes will be ignored. When LEN is 0, the frame is ignored, and the PN532 waits for a new frame.

In case of data rate at 106 kbps in NFC communication mode, the reception ends when the CIU detects an end of frame, except if the CIU detects more bytes than indicated by the received LEN byte. In that case, after receiving LEN bytes, a new reception restarts and the CIU timer starts (if Tauto in register CIU_TMode [Table 252](#) is set to logic 1). The end of reception is then seen if a new valid frame is received or the firmware has to end the reception phase on time-out.

In all other cases, the end of the reception is detected by the end of frame.

In case no frame is received and Tauto in register CIU_TMode [Table 252](#) is set to logic 1, then TimerIRQ in register CommIRQ is set to logic 1. The firmware has to end the reception phase.

Note: If the bit RxMultiple in the register CIU_RxMode is set to logic 1, the Receive command does not terminate automatically. It has to be terminated by setting any other command in the CIU_Command register.

8.6.20.11 Transceive command

This circular command repeats transmitting data from the FIFO and receiving data from the RF field continuously. If the bit Initiator in the register CIU_Control is set to logic 1, it indicates that the first action is transmitting and after having finished transmission the receiver is activated to receive data. If the bit Initiator in the CIU_Control register is set to logic 0, the first action is receiving and after having received a data stream, the transmitter is activated to transmit data. In the second configuration the PN532 first acts as a receiver and if a data stream is received it switches to the Transmit mode.

The end of the reception phase is detected in the same way than for the receive command and also when the RF field is cut.

The transceive command always take into account the presence or absence of the RF field. No transmission or reception can be done when no RF field.

Table 168. Transceive command scenario

Communication step	Initiator =1	Initiator=0
1	Send	Receive
2	Receive	Send
3	Send	Receive
4	Receive	Send

Each transmission process has to be started with setting bit StartSend in the register CIU_BitFraming. This command has to be cleared by firmware by writing any command to the CIU_Command register e.g. the command idle.

Note: If the bit RxMultiple in register CIU_RxMode is set, this command will never leave the receiving state, because the receiving will not be cancelled automatically.

8.6.20.12 AutoColl command

This command automatically handles the MIFARE activation and the FeliCa polling in the Card Operation mode. The bit Initiator in the CIU_Control register has to be set to logic 0 for correct operation. During this command, Mode Detector is active if not deactivated by setting the bit ModeDetOff in the CIU_Mode register. After Mode Detector detects a mode, the mode dependent registers are set according to the received data. In case of no external RF field this command resets the internal state machine and returns to the initial state but it will not be terminated.

When the Autocoll command terminates the Transceive command gets active.

During Autocoll command:

- The CIU interrupt bits, except RfOnIRq, RfOffIRq and SIGINActIRq (see [Table 187 on page 148](#)), are not supported. Only the last received frame will serve the CIU interrupts.
- During ISO/IEC 14443A activation, TxCRCEn and RxCRCEn bits are defined by the AutoColl command. The changes cannot be observed at the CIU_TxMode and CIU_RxMode registers. When the Transceive command is active, the value of the bits is relevant.
- During Felica activation (polling), TxCRCEn and RxCRCEn bits are always relevant and are not overruled by the Autocoll command. Their value must be set to logic 1 according the FeliCa protocol.

Note: Pay attention, that the FIFO will also receive the two CRC check bytes of the last command, even if they are already checked and correct, and if the state machine (Anticollision and Select routine) has not been executed, and 106 kbit is detected.

This command can be cleared by firmware by writing any other command to the CIU_Command register, e.g. the Idle command. Writing the same content again to the CIU_Command register resets the state machine.

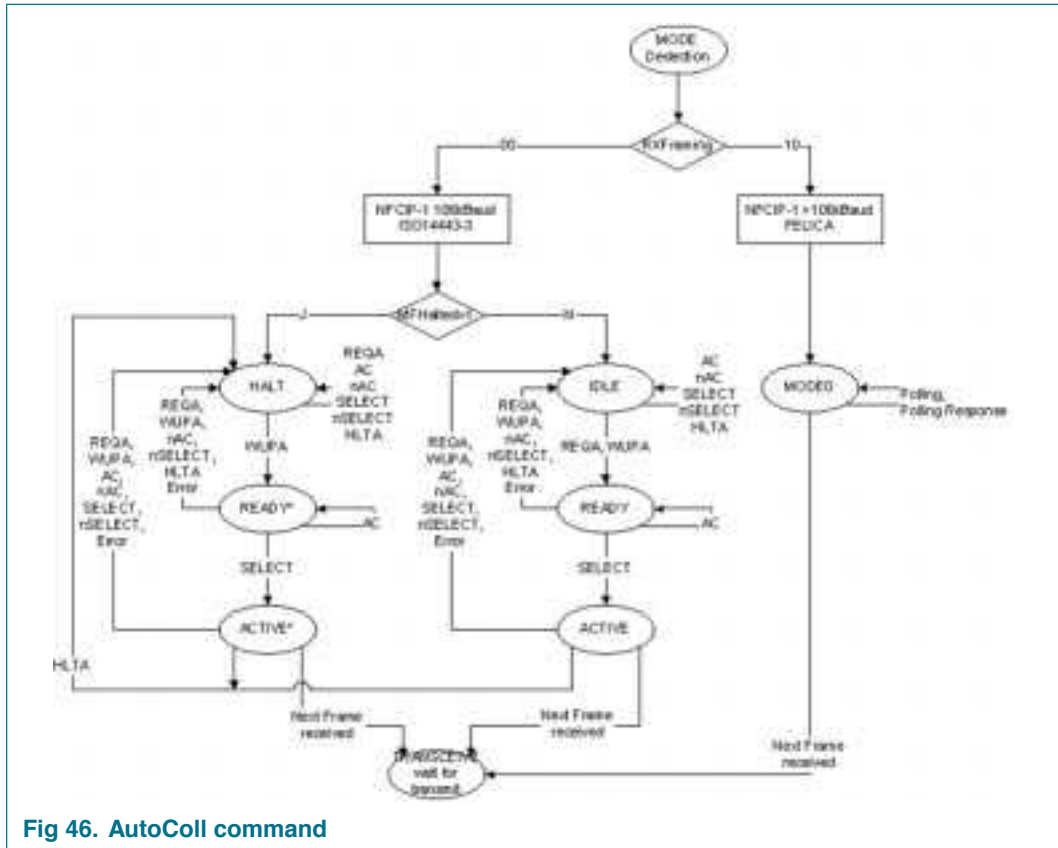

Fig 46. AutoColl command

- NFCIP-1 106 kbps passive communication mode:**

The MIFARE anticollision is finished and the command changes automatically to Transceive. The FIFO contains the ATR_REQ frame including the start byte F0h. The bit TargetActivated in the register CIU_Status2 is set to logic 1
- NFCIP-1 212 and 424 kbps passive communication mode:**

The FeliCa polling command is finished and the command has automatically changed to Transceive. The FIFO contains the ATR_REQ frame. The bit TargetActivated in the register CIU_Status2 is set to logic 1.
- NFCIP-1 106, 212 and 424 kbps active communication mode:**

This command is changing automatically to Transceive. The FIFO contains the ATR_REQ frame. The bit TargetActivated in the register CIU_Status2 is set to logic 0. For 106 kbps only, the first byte in the FIFO indicates the start byte F0h and the CRC is added into the FIFO.
- ISO/IEC 14443A/MIFARE (Card Operating mode):**

The MIFARE anticollision is finished and the command has automatically changed to Transceive. The FIFO contains the first command after the Select. The bit TargetActivated in the register CIU_Status2 is set to logic 1.
- FeliCa (Card Operating mode):**

The FeliCa polling command is finished and the command has automatically changed to Transceive. The FIFO contains the command after the Polling in the FeliCa protocol. The bit TargetActivated in the register CIU_Status2 is set to logic 1.

8.6.20.13 MFAuthent command

This command handles the MIFARE authentication in Reader/Writer mode to enable a secure communication to any MIFARE 1 KB and MIFARE 4 KB emulation card. The following data shall be written to the FIFO before the command can be activated:

- Authentication command code (60h for key A, 61h for key B)
- Block address
- Sector key byte 0
- Sector key byte 1
- Sector key byte 2
- Sector key byte 3
- Sector key byte 4
- Sector key byte 5
- Card serial number byte 0
- Card serial number byte 1
- Card serial number byte 2
- Card serial number byte 3

In total 12 bytes shall be written to the FIFO.

Note: When the MFAuthent command is active, any FIFO access is blocked. Anyhow if there is an access to the FIFO, the bit WrErr in the register CIU_Error is set to logic 1.

This command terminates automatically when the MIFARE 1KB or MIFARE 4 KB emulation card is authenticated. The bit MFCrypto1On in the register CIU_Status2 is set to logic 1.

This command does not terminate automatically when the card does not answer, therefore CIU timer should be initialized to automatic mode. In this case, beside the bit IdleIRq, the bit TimerIRq can be used as termination criteria. During authentication processing, the bits RxIRq and TxIRq of CIU_CommIrq register are blocked.

The Crypto1On bit is only valid after termination of the MFAuthent command (either after processing the authentication or after writing the Idle command in the register CIU_Command).

In case there is an error during the MIFARE authentication, the ProtocolErr bit in the CIU_Error register is set to logic 1 and the Crypto1On bit in CIU_Status2 register is set to logic 0.

8.6.20.14 SoftReset command

This command performs a reset of the CIU. The configuration data of the internal buffer remains unchanged. All registers are set to the reset values.

When SoftReset is finished, the active command switches to Idle.

8.6.21 CIU tests signals

8.6.21.1 CIU self-test

The CIU has the capability to perform a self-test. To start the self-test the following procedure has to be performed:

1. Perform a SoftReset.
2. Clear the internal buffer by writing 25 bytes of 00h and perform the Config command.
3. Enable the self-test by writing the value 09h to the register CIU_AutoTest.
4. Write 00h to the FIFO.
5. Start the self-test with the CalcCRC command.
6. The self-test will be performed.
7. When the self-test is finished, the FIFO contains the following bytes:
 - Correct answer for VersionReg equal to 80h:
0x00, 0xaa, 0xe3, 0x29, 0x0c, 0x10, 0x29, 0x6b
0x76, 0x8d, 0xaf, 0x4b, 0xa2, 0xda, 0x76, 0x99
0xc7, 0x5e, 0x24, 0x69, 0xd2, 0xba, 0xfa, 0xbc
0x3e, 0xda, 0x96, 0xb5, 0xf5, 0x94, 0xb0, 0x3a
0x4e, 0xc3, 0x9d, 0x94, 0x76, 0x4c, 0xea, 0x5e
0x38, 0x10, 0x8f, 0x2d, 0x21, 0x4b, 0x52, 0xbf
0xfb, 0xf4, 0x19, 0x94, 0x82, 0x5a, 0x72, 0x9d
0xba, 0x0d, 0x1f, 0x17, 0x56, 0x22, 0xb9, 0x08

8.6.21.2 CIU test bus

The test bus is implemented for production test purposes. The following configuration can be used to improve the design of a system using the PN532. The test bus allows to route internal signals to output pins.

The Observe_testbus register is used to enable this functionality.

Table 169. Observe_testbus register (address 6104h) bit allocation

Bit	7	6	5	4	3	2	1	0
Symbol	-	-	-	-	-	-	-	observe_ciu
Reset	0	0	0	0	0	0	0	0
Access	R	R	R	R	R	R	R	R/W

Table 170. Description of Observe_testbus bits

Bit	Symbol	Description
7 to 1	-	Reserved.
0	observe_ciu	<p>Configure the pads P3x (P30 to P35), RSTOUT_N and P70_IRQ to observe internal CIU data bus.</p> <p>When set to logic 1, the pads are configured in output mode and show the internal data bus D0 to D6 of the CIU. P70_IRQ is the 13.56 MHz digital clock of CIU (generated from field or crystal).</p>

The test bus signals are selected by accessing TestBusSel in register CIU_TestSel2.

Table 171. TstBusBitSel set to 07h

Test bus bit	Test signal	Comments
D6	sdata	shows the actual received data value.
D5	scoll	shows if in the actual bit a collision has been detected (106 kbit/s only)
D4	svalid	shows if sdata and scoll are valid
D3	sover	shows that the receiver has detected a stop bit (ISO/IEC 14443A/MIFARE mode only)
D2	RCV_reset	shows if the receiver is reset
D1	RFon filtered	shows the value of the internal RF level detector
D0	Envelope	shows the output of the internal coder

Table 172. TstBusBitSel set to 0Dh

Test bus bit	Test signal	Comments
D6	clkstable	shows if the oscillator delivers a stable signal
D5	clk27/8	shows the output signal of the oscillator divided by 8
D4	clk27rf/8	shows the clk27rf signal divided by 8
D3	clk13/4	shows the clk13rf divided by 4
D2	clk27	shows the output signal of the oscillator
D1	clk27rf	shows the RF clock multiplied by 2
D0	clk13rf	shows the RF clock of 13.56 MHz

8.6.21.3 Test signals at pin AUX

Each signal can be switched to pin AUX1 or AUX2 by setting SelAux1 or SelAux2 in the register CIU_AnalogTest. See [Table 279 on page 184](#)

8.6.21.4 PRBS

Enables the Pseudo Random Bit Stream of 9-bit or 15-bit length sequence, PRBS9 or PRBS15, according to ITU-T0150. To start the transmission of the defined datastream, Transmit command has to be activated. The preamble/Sync byte/start bit/parity bit are generated automatically depending on the selected mode.

Note: All relevant registers to transmit data have to be configured before entering PRBS mode according ITU-T0150.

8.6.22 CIU memory map

The registers of the CIU are either map into the SFR or into the XRAM memory space.

Table 173. Contactless Interface Unit SFR memory map

ADDR	Byte size	Register name	Description
D1h	1	CIU_Command	Starts and stops the command execution
D2h	1	CIU_CommlEn	Control bits to enable and disable the passing of interrupt requests
D3h	1	CIU_DivlEn	Control bits to enable and disable the passing of interrupt requests
D4h	1	CIU_Commlrq	Contains common Interrupt Request flags
D5h	1	CIU_Divlrq	Contains diverse Interrupt Request flags
D6h	1	CIU_Error	Error flags showing the error status of the last command executed
DFh	1	CIU_Status1	Contains status flags of the CRC, Interrupt Request System and FIFO buffer
E9h	1	CIU_Status2	Contain status flags of the Receiver, Transmitter and Data Mode Detector
EAh	1	CIU_FIFOData	in- and output of 64 bytes FIFO buffer
EBh	1	CIU_FIFOLevel	Indicates the number of bytes stored in the FIFO
ECh	1	CIU_WaterLevel	Defines the thresholds for FIFO under- and overflow warning
EDh	1	CIU_Control	Contains miscellaneous Control bits
EEh	1	CIU_BitFraming	Adjustments for bit oriented frames
EFh	1	CIU_Coll	Bit position of the first bit collision detected on the RF-interface

Table 174. Contactless Interface Unit extension memory map

ADDR	Byte size	Register name	Description
6301h	1	CIU_Mode	Defines general modes for transmitting and receiving
6302h	1	CIU_TxMode	Defines the transmission data rate and framing during transmission
6303h	1	CIU_RxMode	Defines the transmission data rate and framing during receiving
6304h	1	CIU_TxControl	Controls the logical behavior of the antenna driver pins TX1 and TX2
6305h	1	CIU_TxAuto	Controls the settings of the antenna driver
6306h	1	CIU_TxSel	Selects the internal sources for the antenna driver
	1	CIU_RxSel	Selects internal receiver settings
6308h	1	CIU_RxThreshold	Selects thresholds for the bit decoder
6309h	1	CIU_Demod	Defines demodulator settings
630Ah	1	CIU_FelNFC1	Defines the length of the valid range for the received frame
630Bh	1	CIU_FelNFC2	Defines the length of the valid range for the received frame
630Ch	1	CIU_MifNFC	Controls the communication in ISO/IEC 14443/MIFARE and NFC target mode at 106 kbit/s
630Dh	1	CIU_ManualRCV	Allows manual fine tuning of the internal receiver

Table 174. Contactless Interface Unit extension memory map ...continued

ADDR	Byte size	Register name	Description
630Eh	1	CIU_TypeB	Configure the ISO/IEC 14443 type B
630Fh	1	-	Reserved
6310h	1	-	Reserved
6311h	1	CIU_CRCResultMSB	Shows the actual MSB values of the CRC calculation
6312h	1	CIU_CRCResultLSB	Shows the actual LSB values of the CRC calculation
6313h	1	CIU_GsNOff	Selects the conductance of the antenna driver pins TX1 and TX2 for load modulation when own RF field is switched OFF
6314h	1	CIU_ModWidth	Controls the setting of the width of the Miller pause
6315h	1	CIU_TxBitPhase	Bit synchronization at 106 kbit/s
6316h	1	CIU_RFCfg	Configures the receiver gain and RF level
6317h	1	CIU_GsNON	Selects the conductance of the antenna driver pins TX1 and TX2 for modulation, when own RF field is switched ON
6318h	1	CIU_CWGsP	Selects the conductance of the antenna driver pins TX1 and TX2 when not in modulation phase
6319h	1	CIU_ModGsP	Selects the conductance of the antenna driver pins TX1 and TX2 when in modulation phase
631Ah	1	CIU_TMode	Defines settings for the internal timer
631Bh	1	CIU_TPrescaler	
631Ch	1	CIU_TReloadVal_hi	Describes the 16-bit long timer reload value (Higher 8 bits)
631Dh	1	CIU_TReloadVal_lo	Describes the 16-bit long timer reload value (Lower 8 bits)
631Eh	1	CIU_TCounterVal_hi	Describes the 16-bit long timer actual value (Higher 8 bits)
631Fh	1	CIU_TCounterVal_lo	Describes the 16-bit long timer actual value (Lower 8 bits)
6320h	1	-	Reserved
6321h	1	CIU_TestSel1	General test signals configuration
6322h	1	CIU_TestSel2	General test signals configuration and PRBS control
6323h	1	CIU_TestPinEn	Enables test signals output on pins.
6324h	1	CIU_TestPinValue	Defines the values for the 8-bit parallel bus when it is used as I/O bus
6325h	1	CIU_TestBus	Shows the status of the internal test bus
6326h	1	CIU_AutoTest	Controls the digital self-test
6327h	1	CIU_Version	Shows the CIU version
6328h	1	CIU_AnalogTest	Controls the pins AUX1 and AUX2
6329h	1	CIU_TestDAC1	Defines the test value for the TestDAC1
632Ah	1	CIU_TestDAC2	Defines the test value for the TestDAC2
632Bh	1	CIU_TestADC	Show the actual value of ADC I and Q
632Ch	1	-	Reserved for tests
632Dh	1	-	Reserved for tests
632Eh	1	-	Reserved for tests
632Fh	1	CIU_RFlevelDet	Power down of the RF level detector
6330h	1	CIU_SIC_CLK_en	Enables the use of secure IC clock on P34 / SIC_CLK.

8.6.23 CIU register description

8.6.23.1 CIU register bit behavior

Depending of the functionality of a register, the access condition to the bits can vary. The following table describes the access conditions:

Table 175. Behavior of register bits

Abbreviation	Behavior	Description
R/W	Read and Write	These bits can be written and read by the 80C51. Since they are used only for control means, there content is not influenced by internal state machines, e.g. CIU_CommIEEn may be written and read by the CPU. It will also be read by internal state machines, but never changed by them.
DY	DYnamic	These bits can be written and read by the 80C51. Nevertheless, they may also be written automatically by CIU internal state machines, e.g. the commands in the CIU_Command register change their values automatically after their execution.
R	Read only	These registers hold flags, which value is determined by CIU internal states only, e.g. the CRCReady register can not be written from external but shows CIU internal states.
W	Write only	These registers are used for control means only. They may be written by the 80C51 but can not be read. Reading these registers returns always logic 0.
Reserved		These registers are not implemented or reserved for NXP testing use.

8.6.23.2 CIU_SIC_CLK_en register (6330h)

Enables the use of P34 / SIC_CLK as secure IC clock.

Table 176. CIU_SIC_CLK_en register (address 6330h) bit allocation

Bit	7	6	5	4	3	2	1	0
Symbol	sic_clk_p34_en	-	-	-	Errorbusbitenable	Errorbusbitsel[2:0]		
Reset	0	0	0	0	0	0	0	0
Access	R/W	R	R	R	R/W	R/W	R/W	R/W

Table 177. Description of CIU_SIC_CLK_en bits

Bit	Symbol	Description																		
7	sic_clk_p34_en	Set to logic 1, this bit configures P34 / SIC_CLK to be used as secure IC clock: SIC_CLK. Set to logic 0, P34 / SIC_CLK is in normal mode: P34.																		
6 to 4	-	Reserved																		
3	Errorbusbitenable	Set to logic 1, enable the error source selected by Errorbusbitsel on AUX pads according to SelAux1 and SelAux2 bits (code 1010b).																		
2 to 0	Errorbusbitsel[2:0]	Define the error source on ErrorBusBit: <table border="1" style="margin-left: 20px;"> <thead> <tr> <th>Value</th> <th>Description</th> </tr> </thead> <tbody> <tr> <td>000</td> <td>selects ProtocolErr on test bus</td> </tr> <tr> <td>001</td> <td>selects ParityErr on test bus</td> </tr> <tr> <td>010</td> <td>selects CRCErr on test bus</td> </tr> <tr> <td>011</td> <td>selects CollErr on test bus</td> </tr> <tr> <td>100</td> <td>selects BufferOvfl on test bus</td> </tr> <tr> <td>101</td> <td>selects RFErr on test bus</td> </tr> <tr> <td>110</td> <td>selects TempErr on test bus</td> </tr> <tr> <td>111</td> <td>selects WrErr on test bus</td> </tr> </tbody> </table>	Value	Description	000	selects ProtocolErr on test bus	001	selects ParityErr on test bus	010	selects CRCErr on test bus	011	selects CollErr on test bus	100	selects BufferOvfl on test bus	101	selects RFErr on test bus	110	selects TempErr on test bus	111	selects WrErr on test bus
Value	Description																			
000	selects ProtocolErr on test bus																			
001	selects ParityErr on test bus																			
010	selects CRCErr on test bus																			
011	selects CollErr on test bus																			
100	selects BufferOvfl on test bus																			
101	selects RFErr on test bus																			
110	selects TempErr on test bus																			
111	selects WrErr on test bus																			

8.6.23.3 CIU_Command register (D1h or 6331h)

Starts and stops the command execution.

Table 178. CIU_Command register (address D1h or 6331h) bit allocation

Bit	7	6	5	4	3	2	1	0
Symbol	-	-	RcvOff	Power-down	Command			
Reset	0	0	1	0	0	0	0	0
Access	R	R	R/W	DY	DY	DY	DY	DY

Table 179. Description of CIU_Command bits

Bit	Symbol	Description
7 to 6	-	Reserved
5	RcvOff	Set to logic 1, the analog part of the receiver is switched off.
4	Power-down	Set to logic 1, the CIU Power-down mode is entered. This means, internal current consuming blocks of the contactless analog module are switched off, except for the RF level detector. Set to logic 0, the PN532 starts the wake up procedure. During this procedure this bit still shows a logic 1. A logic 0 indicates that the PN532 is ready for operations; see Section 8.6.19.2 "CIU Power-down" on page 131 .
3 to 0	Command	Activates a command according the Command Code. Reading this register shows, which command is actually executed. See Section 8.6.20 "CIU command set" on page 132

8.6.23.4 CIU_CommIEn register (D2h or 6332h)

Control bits to enable and disable the passing of interrupt requests.

Table 180. CIU_CommIEn register (address D2h or 6332h) bit allocation

Bit	7	6	5	4	3	2	1	0
Symbol	-	TxIEn	RxIEn	IdleIEn	HiAlertIEn	LoAlertIEn	ErrIEn	TimerIEn
Reset	0	0	0	0	0	0	0	0
Access	R	R/W	R/W	R/W	R/W	R/W	R/W	R/W

Table 181. Description of CIU_CommIEn bits

Bit	Symbol	Description
7	-	Reserved.
6	TxIEn	When set to logic 1, allows the transmitter interrupt request (indicated by bit TxIRq) to be propagated to CIU_IRQ_1.
5	RxIEn	When set to logic 1, allows the receiver interrupt request (indicated by bit RxIRq) to be propagated to CIU_IRQ_1.
4	IdleIEn	When set to logic 1, allows the idle interrupt request (indicated by bit IdleIRq) to be propagated to CIU_IRQ_0.
3	HiAlertIEn	When set to logic 1, allows the high alert interrupt request (indicated by bit HiAlertIRq) to be propagated to CIU_IRQ_1.
2	LoAlertIEn	When set to logic 1, allows the low alert interrupt request (indicated by bit LoAlertIRq) to be propagated to CIU_IRQ_1.
1	ErrIEn	When set to logic 1, allows the error interrupt request (indicated by bit ErrIRq) to be propagated to CIU_IRQ_0.
0	TimerIEn	When set to logic 1, allows the timer interrupt request (indicated by bit TimerIRq) to be propagated to CIU_IRQ_0.

8.6.23.5 CIU_DivIEn register (D3h or 6333h)

Controls bits to enable and disable the passing of interrupt requests.

Table 182. CIU_DivIEn register (address D3h or 6333h) bit allocation

Bit	7	6	5	4	3	2	1	0
Symbol	-	-	-	SignAct IEn	ModeIEn	CRCIEn	RfOnIEn	RfOffIEn
Reset	0	0	0	0	0	0	0	0
Access	R	R	R	R/W	R/W	R/W	R/W	R/W

Table 183. Description of CIU_DivIEn bits

Bit	Symbol	Description
7 to 5	-	Reserved.
4	SignAct IEn	Allows the SIGIN active interrupt request to be propagated to CIU_IRQ_0.
3	ModeIEn	When set to logic 1, allows the mode interrupt request (indicated by bit ModeIRq) to be propagated to CIU_IRQ_0.
2	CRCIEn	When set to logic 1, allows the CRC interrupt request (indicated by bit CRCIRq) to be propagated to CIU_IRQ_0.
1	RfOnIEn	When set to logic 1, allows the RF field on interrupt request (indicated by bit RfOnIRq) to be propagated to CIU_IRQ_0.
0	RfOffIEn	When set to logic 1, allows the RF field off interrupt request (indicated by bit RfOffIRq) to be propagated to CIU_IRQ_0.

8.6.23.6 CIU_Commlrq register (D4h or 6334h)

Contains common CIU interrupt request flags.

Table 184. CIU_Commlrq register (address D4h or 6334h) bit allocation

Bit	7	6	5	4	3	2	1	0
Symbol	Set1	TxIRq	RxIRq	IdleIrq	HiAlertIRq	LoAlertIRq	ErrIRq	TimerIRq
Reset	0	0	0	1	0	1	0	0
Access	W	DY	DY	DY	DY	DY	DY	DY

Table 185. Description of CIU_Commlrq bits

Bit	Symbol	Description
7	Set1	When set to logic 0 during write operation, the bit set to logic 1 in the write command are written to logic 0 in the register. When set to logic 1 during write operation, the bit set to logic 1 in the write command are written to logic 1 in the register.
6	TxIRq	Set to logic 1, immediately after the last bit of the transmitted data was sent out.
5	RxIRq	Set to logic 1 when the receiver detects the end of a valid datastream. If the RxNoErr bit in CIU_RxMode register is set to logic 1, RxIRQ is only set to logic 1 when data bytes are available in the FIFO.
4	IdleIrq	Set to logic 1, when a command terminates by itself e.g. when the CIU_Command register changes its value from any command to the Idle command. If an unknown command is started, the CIU_Command register changes its value to the Idle command and the IdleIrq bit is set. Starting the Idle Command by the 80C51 does not set IdleIrq bit.
3	HiAlertIRq	Set to logic 1, when HiAlert bit in CIU_Status1 register is set to logic 1. In opposition to HiAlert, HiAlertIRq stores this event and can only be reset by Set1 bit.
2	LoAlertIRq	Set to logic 1, when LoAlert bit in CIU_Status1 register is set. In opposition to LoAlert, LoAlertIRq stores this event and can only be reset by Set1 bit.
1	ErrIRq	Set to logic 1, if any error flag in the CIU_Error register is set.
0	TimerIRq	Set to logic 1, when the timer decrements the TimerValue register to zero.

[1] **Remark:** All bits in the register CIU_Commlrq shall be set to logic 0 by firmware.

8.6.23.7 CIU_DivIrq register (D5h or 6335h)

Contains miscellaneous interrupt request flags. These bits are latched.

Table 186. CIU_DivIrq register (address D5h or 6335h) bit allocation

Bit	7	6	5	4	3	2	1	0
Symbol	Set2	-	-	SiginActIrq	ModeIRq	CRCIRq	RfOnIRq	RfOffIRq
Reset	0	0	0	X	0	0	X	X
Access	W	R	R	DY	DY	DY	DY	DY

Table 187. Description of CIU_DivIrq bits

Bit	Symbol	Description
7	Set2	When set to logic level 0 during write operation, the bit set to logic 1 in the write command are written to logic 0 in the register. When set to logic level 1 during write operation, the bit set to logic 1 in the write command are written to logic 1 in the register.
6 to 5	-	Reserved.
4	SiginActIrq	Set to logic 1, when SIGIN is active. See Section 8.6.13 “NFC-WI/S²C interface support” on page 122 . This interrupt is set to logic 1 when either a rising or falling edge is detected on SIGIN. ^[1]
3	ModeIRq	Set to logic level 1, when the mode has been detected by the Data Mode Detector. Note: The Data Mode Detector can only be activated by the AutoColl command and is terminated automatically having the detected the communication mode. Note: The Data Mode Detector is automatically restarted after each RF reset.
2	CRCIRq	Set to logic level 1, when the CRC command is active and all data are processed.
1	RfOnIRq	Set to logic level 1, when an external RF field is detected. ^{[1][2]}
0	RfOffIRq	Set to logic level 1, when an present external RF field is switched off. ^{[1][2]}

[1] At power-up, after reset modes (including Hard Power Down), the logical value of this bit is undefined.

[2] After Power-Down bit of [Table 181 on page 146](#) goes from logic 1 to logic 0, after pd_rflveldet bit of [Table 286 on page 187](#) goes from logic 1 to logic 0, the logical value of this bit is undefined.

8.6.23.8 CIU_Error register (D6h or 6336h)

Error flags showing the error status of the last command executed.

Table 188. CIU_Error register (address D6h or 6336h) bit allocation

Bit	7	6	5	4	3	2	1	0
Symbol	WrErr	TempErr	RFErr	BufferOvfl	CollErr	CRCErr	ParityErr	ProtocollErr
Reset	0	0	0	0	0	0	0	0
Access	R	R	R	R	R	R	R	R

Table 189. Description of CIU_Error bits

Bit	Symbol	Description
7	WrErr	Set to logic 1, when data is written into the FIFO by the 80C51 during the AutoColl command or MFAuthent command or if data is written into the FIFO by the 80C51 during the time between sending the last bit on the RF interface and receiving the last bit on the RF interface.
6	TempErr ^[1]	Set to logic 1, if the internal temperature sensor detects overheating. In this case the antenna drivers are switched off automatically.
5	RFErr	Set to logic 1, if in active communication mode the counterpart does not switch on the RF field in time as defined in NFCIP-1 standard. Note: RFErr is only used in active communication mode. The bit RxFraming or the bit TxFraming has to be set to 01h to enable this functionality.
4	BufferOvfl	Set to logic 1, if the 80C51 or if the internal state machine (e.g. receiver) tries to write data into the FIFO buffer although the FIFO buffer is already full.
3	CollErr	Set to logic 1, if a bit-collision is detected. It is set to logic 0 automatically at receiver start phase. This flag is only valid during the bitwise anticollision at 106 kbit/s. During communication schemes at 212 and 424 kbit/s this flag is always set to logic 0.
2	CRCErr	Set to logic 1, if RxCRCEn in CIU_RxMode register is set to logic 1 and the CRC calculation fails. It is set to logic 0 automatically at receiver start-up phase.
1	ParityErr	Set to logic 1, if the parity check has failed. It is set to logic 0 automatically at receiver start-up phase. Only valid for ISO/IEC 14443A/MIFARE or NFCIP-1 communication at 106 kbit/s.
0	ProtocollErr	Set to logic 1, if one out of the following cases occurs: <ul style="list-style-type: none"> Set to logic 1 if the SOF is incorrect. It is set to logic 0 automatically at receiver start-up phase. The bit is only valid for 106 kbit in Active and Passive Communication mode. If bit DetectSync in CIU_Mode register is set to logic 1 during FeliCa communication or Active Communication with transfer speeds higher than 106 kbit, ProtocolErr is set to logic 1 in case of a byte length violation. During the AutoColl command, ProtocolErr is set to logic 1, if the Initiator bit in CIU_Control register is set to logic 1. During the MFAuthent Command, ProtocolErr is set to logic 1, if the number of bytes received in one data stream is incorrect. Set to logic 1, if the Miller Decoder detects 2 pauses below the minimum time according to the ISO/IEC 14443A definitions.

[1] Command execution will clear all error flags except for bit TempErr. A setting by firmware is impossible.

8.6.23.9 CIU_Status1 register (DFh or 6337h)

Contains status flags of the CRC, Interrupt Request System and FIFO buffer.

Table 190. CIU_Status1 register (address DFh or 6337h) bit allocation

Bit	7	6	5	4	3	2	1	0
Symbol	CIU_IRQ_1	CRCOk	CRCReady	CIU_IRQ_0	TRunning	RFOn	HiAlert	LoAlert
Reset	0	0	1	0	0	X	0	1
Access	R	R	R	R	R	R	R	R

Table 191. Description of CIU_Status1 bits

Bit	Symbol	Description
7	CIU_IRQ_1	<p>This bit shows, if any CIU_IRQ_1 source requests attention (with respect to the setting of the interrupt enable flags, see CIU_CommIE n and CIU_DivIE n registers).</p> <p>The bit IE1_2 of register IE1 (see Table 13 on page 18) has to be set to logic 1 to enable the corresponding CPU interrupt.</p>
6	CRCOk	<p>Set to logic 1, the CRC result is zero. For data transmission and reception the bit CRCOk is undefined (use CRCErr in CIU_Error register). CRCOk indicates the status of the CRC coprocessor, during calculation the value changes to logic 0, when the calculation is done correctly, the value changes to logic 1.</p>
5	CRCReady	<p>Set to logic 1, when the CRC calculation has finished. This bit is only valid for the CRC co-processor calculation using the CalcCRC command.</p>
4	CIU_IRQ_0	<p>This bit shows, if any CIU_IRQ_0 source requests attention (with respect to the setting of the interrupt enable flags, see CIU_CommIE n and CIU_DivIE n registers).</p> <p>The bit IE1_3 of register IE1 (see Table 13 on page 18) has to be set to logic 1 to enable the corresponding CPU interrupt.</p>
3	TRunning	<p>Set to logic 1, the CIU_timer is running, e.g. the CIU_timer will decrement the CIU_TCounterVal_lo with the next timer clock.</p> <p>Note: In the gated mode TRunning is set to logic 1, when the CIU_timer is enabled by the register bits. This bit is not influenced by the gated signal.</p>
2	RFO n	<p>Set to logic 1, if an external RF field is detected. This bit does not store the state of the RF field.</p>
1	HiAlert	<p>Set to logic 1, when the number of bytes stored in the FIFO buffer fulfills the following equation:</p> $HiAlert = (64 - FIFOLength) \leq WaterLevel$ $FIFOLength = 60, WaterLevel = 4 \rightarrow HiAlert = 1$ <p>Example:</p> $FIFOLength = 59, WaterLevel = 4 \rightarrow HiAlert = 0$
0	LoAlert	<p>Set to logic 1, when the number of bytes stored in the FIFO buffer fulfills the following equation:</p> $LoAlert = FIFOLength \leq WaterLevel$ <p>Example:</p> $FIFOLength = 4, WaterLevel = 4 \rightarrow LoAlert = 1$ $FIFOLength = 5, WaterLevel = 4 \rightarrow LoAlert = 0$

8.6.23.10 CIU_Status2 register (E9h or 6338h)

Contain status flags of the receiver, transmitter and Data Mode Detector.

Table 192. CIU_Status2 register (address E9h or 6338h) bit allocation

Bit	7	6	5	4	3	2	1	0
Symbol	TempSensClear	-	RFFreqOK	TgActivated	MFCrypto1On	ModemState[2:0]		
Reset	0	0	0	0	0	0	0	0
Access	R/W	R	R	DY	DY	R	R	R

Table 193. Description of CIU_Status2 bits

Bit	Symbol	Description
7	TempSensClear	Set to logic 1, this bit clears the temperature error, if the temperature is below the alarm limit of 125 °C.
6	-	Reserved
5	RFFreqOK	Indicates if the frequency detected at the RX pin is in the range of 13.56 MHz. Set to logic 1, if the frequency at the RX pin is in the range 12 MHz < RX pin frequency < 15 MHz. Note: The value of RFFreqOK is not defined if the external RF frequency is in the range of 9 to 12 MHz or in the range of 15 to 19 MHz.
4	TgActivated	Set to logic 1 if the Select command is received correctly or if the Polling command was answered. Note: This bit can only be set during the AutoColl command in Passive Communication mode or Card operating modes. Note: This bit is set to logic 0 automatically by switching off the RF field.
3	MFCrypto1On	Set to logic 1, MIFARE Crypto1 unit is switched on and therefore all data communication with the card is encrypted. This bit can only be set to logic 1 by a successful execution of the MFAuthent command. This is only valid in Reader/Writer mode for MIFARE 1 KB or MIFARE 4 KB emulation cards. This bit shall be set to logic 0 by firmware.
2 to 0	ModemState[2:0]	ModemState shows the state of the transmitter and receiver state machines. Value Description 000 Idle 001 Wait for StartSend in CIU_BitFraming register 010 TxWait: Wait until RF field is present, if TxWaitRF is set to logic 1. The minimum time for TxWait is defined by the TxWait register. 011 Transmitting 100 RxWait: Wait until RF field is present, if the bit RxWaitRF is set to logic 1. The minimum time for RxWait is defined by the RxWait register 101 Wait for data 110 Receiving

8.6.23.11 CIU_FIFOData register (EAh or 6339h)

In- and output of 64 byte FIFO buffer.

Table 194. CIU_FIFOData register (address EAh or 6339h) bit allocation

Bit	7	6	5	4	3	2	1	0
Symbol	FIFOData[7:0]							
Reset	X	X	X	X	X	X	X	X
Access	DY	DY	DY	DY	DY	DY	DY	DY

Table 195. Description of CIU_FIFOData bits

Bit	Symbol	Description
7 to 0	FIFOData[7:0]	Data input and output port for the internal 64 bytes FIFO buffer. The FIFO buffer acts as parallel in/parallel out converter for all data stream in- and outputs

8.6.23.12 CIU_FIFOLevel register (EBh or 633Ah)

Indicates the number of bytes stored in the FIFO.

Table 196. CIU_FIFOLevel register (address EBh or 633Ah) bit allocation

Bit	7	6	5	4	3	2	1	0
Symbol	FlushBuffer	FIFOLevel[6:0]						
Reset	0	0	0	0	0	0	0	0
Access	W	R	R	R	R	R	R	R

Table 197. Description of CIU_FIFOLevel bits

Bit	Symbol	Description
7	FlushBuffer	Set to logic 1, this bit clears the internal FIFO-buffer's read- and write-pointer and the bit BufferOvfl in the CIU_Error register immediately. Reading this bit will always return logic 0.
6 to 0	FIFOLevel[6:0]	Indicates the number of bytes stored in the FIFO buffer. Writing to the CIU_FIFOData Register increments, reading decrements FIFOLevel.

8.6.23.13 CIU_WaterLevel register (ECh or 633Bh)

Defines the thresholds for FIFO under- and overflow warning.

Table 198. CIU_WaterLevel register (address ECh or 633Bh) bit allocation

Bit	7	6	5	4	3	2	1	0
Symbol	-	-	WaterLevel[6:0]					
Reset	0	0	0	0	1	0	0	0
Access	R	R	R/W	R/W	R/W	R/W	R/W	R/W

Table 199. Description of CIU_WaterLevel bits

Bit	Symbol	Description
7 to 6	-	Reserved.
5 to 0	WaterLevel[5:0]	<p>This register defines a threshold to indicate a FIFO buffer over- or underflow to the 80C51:</p> <p>The HiAlert bit in CIU_Status1 register is set to logic 1, if the remaining number of bytes in the FIFO-buffer space is equal or less than the defined WaterLevel[5:0] bits.</p> <p>The LoAlert bit in CIU_Status1 register is set to logic 1, if equal or less than WaterLevel[5:0] bits are in the FIFO.</p> <p>Remark: For the calculation of the HiAlert and LoAlert see Table 191 on page 150.</p>

8.6.23.14 CIU_Control register (EDh or 633Ch)

Contains miscellaneous control bits.

Table 200. CIU_Control register (address EDh or 633Ch) bit allocation

Bit	7	6	5	4	3	2	1	0
Symbol	TStopNow	TStartNow	WrNFCIP-1IDtoFIFO	Initiator	-	RxLastBits[2:0]		
Reset	0	0	0	0	0	0	0	0
Access	W	W	DY	R/W	R	R	R	R

Table 201. Description of CIU_Control bits

Bit	Symbol	Description
7	TStopNow	Set to logic 1, the timer stops immediately. Reading this bit will always return logic 0.
6	TStartNow	Set to logic 1, the timer starts immediately. Reading this bit will always return logic 0.
5	WrNFCIP-1IDtoFIFO	Set to logic 1, the internal stored NFCID3 (10 bytes) is copied into the FIFO. Afterwards the bit is set to logic 0 automatically
4	Initiator	Set to logic 1, the PN532 acts as Initiator or Reader/Writer, otherwise it acts as Target. or a Card.
3	-	Reserved.
2 to 0	RxLastBits[2:0]	Shows the number of valid bits in the last received byte. If set to 000b, the whole byte is valid.

8.6.23.15 CIU_BitFraming register (EEh or 633Dh)

Adjustments for bit oriented frames.

Table 202. CIU_BitFraming register (address EEh or 633Dh) bit allocation

Bit	7	6	5	4	3	2	1	0
Symbol	StartSend	RxAlign[2:0]			-	TxLastBits[2:0]		
Reset	0	0	0	0	0	0	0	0
Access	W	R/W	R/W	R/W	R	R/W	R/W	R/W

Table 203. Description of CIU_BitFraming bits

Bit	Symbol	Description
7	StartSend	Set to logic 1, the transmission of data starts. This bit is only valid in combination with the Transceive command.
6 to 4	RxAlign[2:0]	Used for reception of bit oriented frames: RxAlign[2:0] defines the bit position for the first received bit to be stored in the FIFO. Further received bits are stored in the following bit positions. Example: RxAlign[2:0] = 0: The LSB of the received bit is stored at bit 0, the second received bit is stored at bit position 1. RxAlign[2:0] = 1: The LSB of the received bit is stored at bit 1, the second received bit is stored at bit position 2 RxAlign[2:0] = 7: The LSB of the received bit is stored at bit 7, the second received bit is stored in the following byte at bit position 0. These bits shall only be used for bitwise anticollision at 106 kbit/s in Passive Communication or Reader/Writer mode. In all other modes it shall be set to logic 0.
3	-	Reserved.
2 to 0	TxLastBits[2:0]	Used for transmission of bit oriented frames: TxLastBits defines the number of bits of the last byte that shall be transmitted. A 000b indicates that all bits of the last byte shall be transmitted.

8.6.23.16 CIU_Coll register (EFh or 633Eh)

Defines the first bit collision detected on the RF interface.

Table 204. CIU_Coll register (address EFh or 633Eh) bit allocation

Bit	7	6	5	4	3	2	1	0
Symbol	ValuesAfterColl	-	CollPosNotValid	CollPos				
Reset	1	0	1	X	X	X	X	X
Access	R/W	R	R	R	R	R	R	R

Table 205. Description of CIU_Coll bits

Bit	Symbol	Description
7	ValuesAfterColl	If this bit is set to logic 0, all receiving bits will be cleared after a collision. This bit shall only be used during bitwise anticollision at 106 kbit/s, otherwise it shall be set to logic 1.
6	-	Reserved
5	CollPosNotValid	Set to logic 1, if no Collision is detected or the Position of the collision is out of range of the CollPos[4:0] bits. This bit shall only be interpreted in Passive Communication mode at 106 kbit/s or ISO/IEC 14443A/MIFARE Reader/Writer mode.
4 to 0	CollPos	These bits show the bit position of the first detected collision in a received frame, only data bits are interpreted. Example: 00h indicates a bit collision in the 32 nd bit. 01h indicates a bit collision in the 1 st bit 08h indicates a bit collision in the 8 th bit This bit shall only be interpreted in Passive Communication mode at 106 kbit/s or ISO/IEC 14443A/MIFARE Reader/Writer mode if CollPosNotValid is set to logic 0.

8.6.23.17 CIU_Mode register (6301h)

Defines general modes for transmitting and receiving.

Table 206. CIU_Mode register (address 6301h) bit allocation

Bit	7	6	5	4	3	2	1	0
Symbol	MSBFirst	DetectSync	TXWaitRF	RxWaitRF	PoSigin	ModeDetOff	CRCPreset [1:0]	
Reset	0	0	1	1	1	0	1	1
Access	R/W	R/W	R/W	R/W	R/W	R/W	R/W	R/W

Table 207. Description of CIU_Mode bits

Bit	Symbol	Description										
7	MSBFirst	Set to logic 1, the CRC co-processor calculates the CRC with MSB first. The bit order in the registers CRCResultMSB and the CIU_CRCResultLSB is reversed. Note: During RF communication this bit is ignored.										
6	DetectSync	If set to logic 1, the CIU waits for the F0h byte before the receiver is activated and F0h byte is added as a Sync-byte for transmission. This bit is only valid for 106 kbit/s during NFCIP-1 data exchange protocol. In all other modes it shall be set to logic 0.										
5	TXWaitRF	Set to logic 1 the transmitter in Reader/Writer or Initiator mode for NFCIP-1 can only be started, if an own RF field is generated (i.e. Tx1RFEn and/or Tx2RFEn is set to logic 1).										
4	RxWaitRF	Set to logic 1, the counter for RxWait starts only, if an external RF field is detected in Target mode for NFCIP-1 or in Card Operating mode										
3	PoSigin	PoSigin defines the polarity of the SIGIN pin. Set to logic 1, the polarity of SIGIN pin is active high. Set to logic 0 the polarity of SIGIN pin is active low. Note: The internal envelope signal is coded active low. Note: Changing this bit will generate a SiginActIrq event.										
2	ModeDetOff	Set to logic 1, the internal Data Mode Detector is switched off. Note: The Data Mode Detector is only active during the AutoColl command.										
1 to 0	CRCPreset[1:0]	Defines the preset value for the CRC co-processor for the CalCRC command. Note: During any communication, the preset values is selected automatically according to the mode definition in the CIU_RxMode and CIU_TxMode registers. <table border="1"> <thead> <tr> <th>Value</th> <th>Description</th> </tr> </thead> <tbody> <tr> <td>00</td> <td>00 00</td> </tr> <tr> <td>01</td> <td>63 63</td> </tr> <tr> <td>10</td> <td>A6 71</td> </tr> <tr> <td>11</td> <td>FF FF</td> </tr> </tbody> </table>	Value	Description	00	00 00	01	63 63	10	A6 71	11	FF FF
Value	Description											
00	00 00											
01	63 63											
10	A6 71											
11	FF FF											

8.6.23.18 CIU_TxMode register (6302h)

Defines the transmission data rate and framing during transmission.

Table 208. CIU_TxMode register (address 6302h) bit allocation

Bit	7	6	5	4	3	2	1	0
Symbol	TxCRCEn	TxSpeed[2:0]			InvMod	TxMix	TxFraming[1:0]	
Reset	0	0	0	0	0	0	0	0
Access	R/W	DY	DY	DY	R/W	R/W	DY	DY

Table 209. Description of CIU_TxMode bits

Bit	Symbol	Description																
7	TxCRCEn	Set to logic 1, this bit enables the CRC generation during data transmission. Note: This bit shall only set to logic 0 at 106 kbit/s.																
6 to 4	TxSpeed[2:0]	Defines bit rate while data transmission. <table border="1"> <thead> <tr> <th>Value</th> <th>Description</th> </tr> </thead> <tbody> <tr> <td>000</td> <td>106 kbit/s</td> </tr> <tr> <td>001</td> <td>212 kbit/s</td> </tr> <tr> <td>010</td> <td>424 kbit/s</td> </tr> <tr> <td>011</td> <td>848 kbit/s</td> </tr> <tr> <td>100</td> <td>1696 kbit/s</td> </tr> <tr> <td>101</td> <td>3392 kbit/s</td> </tr> <tr> <td>110 - 111</td> <td>Reserved</td> </tr> </tbody> </table> Note: The bit coding for transfer speeds above 424 kbit/s is equivalent to the bit coding of the Active Communication mode of the 424 kbit/s of the ISO/IEC18092 / ECMA340.	Value	Description	000	106 kbit/s	001	212 kbit/s	010	424 kbit/s	011	848 kbit/s	100	1696 kbit/s	101	3392 kbit/s	110 - 111	Reserved
Value	Description																	
000	106 kbit/s																	
001	212 kbit/s																	
010	424 kbit/s																	
011	848 kbit/s																	
100	1696 kbit/s																	
101	3392 kbit/s																	
110 - 111	Reserved																	
3	InvMod	Set to logic 1, the modulation for transmitting data is inverted.																
2	TxMix	Set to logic 1, the signal at SIGIN is mixed with the internal coder. See Section 8.6.12 "Serial data switch" on page 120 .																
1 to 0	TxFraming[1:0]	Defines the framing used for data transmission. <table border="1"> <thead> <tr> <th>Value</th> <th>Description</th> </tr> </thead> <tbody> <tr> <td>00</td> <td>ISO/IEC 14443A/MIFARE and Passive Communication mode 106 kbit/s</td> </tr> <tr> <td>01</td> <td>Active Communication mode</td> </tr> <tr> <td>10</td> <td>FeliCa and Passive Communication mode at 212 kbit/s and 424 kbit/s</td> </tr> <tr> <td>11</td> <td>ISO/IEC 14443B</td> </tr> </tbody> </table>	Value	Description	00	ISO/IEC 14443A/MIFARE and Passive Communication mode 106 kbit/s	01	Active Communication mode	10	FeliCa and Passive Communication mode at 212 kbit/s and 424 kbit/s	11	ISO/IEC 14443B						
Value	Description																	
00	ISO/IEC 14443A/MIFARE and Passive Communication mode 106 kbit/s																	
01	Active Communication mode																	
10	FeliCa and Passive Communication mode at 212 kbit/s and 424 kbit/s																	
11	ISO/IEC 14443B																	

8.6.23.19 CIU_RxMode register (6303h)

Defines the reception data rate and framing during receiving.

Table 210. CIU_RxMode register (address 6303h) bit allocation

Bit	7	6	5	4	3	2	1	0
Symbol	RXCRCEn	RxSpeed[2:0]			RxNoErr	RxMultiple	RxFraming[1:0]	
Reset	0	0	0	0	0	0	0	0
Access	R/W	DY	DY	DY	R/W	R/W	DY	DY

Table 211. Description of CIU_RxMode bits

Bit	Symbol	Description																
7	RxCRCEn	Set to logic 1, this bit enables the CRC calculation during reception. The CRC bytes will not be written within the CIU FIFO. Note: This bit shall only set to logic 0 at 106 kbit/s.																
6 to 4	RxSpeed[2:0]	Defines the bit rate while data receiving. The analog part of the CIU handles only transfer speeds up to 424 kbit/s internally, the digital part of the CIU handles the higher transfer speeds as well. <table border="1"> <thead> <tr> <th>Value</th> <th>Description</th> </tr> </thead> <tbody> <tr> <td>000</td> <td>106 kbit/s</td> </tr> <tr> <td>001</td> <td>212 kbit/s</td> </tr> <tr> <td>010</td> <td>424 kbit/s</td> </tr> <tr> <td>011</td> <td>848 kbit/s</td> </tr> <tr> <td>100</td> <td>1696 kbit/s</td> </tr> <tr> <td>101</td> <td>3392 kbit/s</td> </tr> <tr> <td>110 - 111</td> <td>Reserved</td> </tr> </tbody> </table> Note: The bit coding for transfer speeds above 424 kbit/s is equivalent to the bit coding of the active communication mode of the 424 kbit/s of the of the ISO/IEC18092 / ECMA340.	Value	Description	000	106 kbit/s	001	212 kbit/s	010	424 kbit/s	011	848 kbit/s	100	1696 kbit/s	101	3392 kbit/s	110 - 111	Reserved
Value	Description																	
000	106 kbit/s																	
001	212 kbit/s																	
010	424 kbit/s																	
011	848 kbit/s																	
100	1696 kbit/s																	
101	3392 kbit/s																	
110 - 111	Reserved																	
3	RxNoErr	If set to logic 1, a not valid received data stream (less than 4 bits received) will be ignored. The receiver will remain active.																
2	RxMultiple	Set to logic 0, the receiver is deactivated after receiving a data frame. Set to logic 1, it is possible to receive more than one data frame. This bit is only valid for 212 and 424 kbit/s to handle the Polling command. Having set this bit, the receive and transceive commands will not end automatically. In this case the multiple receiving can only be deactivated by writing the Idle command to the CIU_Command register or clearing this bit by the 80C51. If set to logic 1, at the end of a received data stream an error byte is added to the FIFO. The error byte is a copy of the CIU_Error register.																
1 to 0	RxFraming[1:0]	Defines the expected framing for data reception. <table border="1"> <thead> <tr> <th>Value</th> <th>Description</th> </tr> </thead> <tbody> <tr> <td>00</td> <td>ISO/IEC 14443A/MIFARE and Passive Communication mode 106 kbit/s</td> </tr> <tr> <td>01</td> <td>Active communication mode</td> </tr> <tr> <td>10</td> <td>FeliCa and Passive Communication mode at 212 kbit/s and 424 kbit/s</td> </tr> <tr> <td>11</td> <td>ISO/IEC 14443B</td> </tr> </tbody> </table>	Value	Description	00	ISO/IEC 14443A/MIFARE and Passive Communication mode 106 kbit/s	01	Active communication mode	10	FeliCa and Passive Communication mode at 212 kbit/s and 424 kbit/s	11	ISO/IEC 14443B						
Value	Description																	
00	ISO/IEC 14443A/MIFARE and Passive Communication mode 106 kbit/s																	
01	Active communication mode																	
10	FeliCa and Passive Communication mode at 212 kbit/s and 424 kbit/s																	
11	ISO/IEC 14443B																	

8.6.23.20 CIU_TxControl register (6304h)

Controls the logical behavior of the antenna driver pins TX1 and TX2. See also [Table 154 on page 113](#) and [Table 155 on page 113](#).

Table 212. CIU_TxControl register (address 6304h) bit allocation

Bit	7	6	5	4	3	2	1	0
Symbol	InvTx2 RFon	InvTx1 RFon	InvTx2 RFOff	InvTx1 RFOff	Tx2 CW	CheckRF	Tx2 RFEn	Tx1 RFEn
Reset	1	0	0	0	0	0	0	0
Access	R/W	R/W	R/W	R/W	R/W	W	R/W	R/W

Table 213. Description of CIU_TxControl bits

Bit	Symbol	Description
7	InvTx2RFon	Set to logic1 and Tx2RFEn set to logic 1, TX2 output signal is inverted.
6	InvTx1RFon	Set to logic1 and Tx1RFEn set to logic 1, TX1 output signal is inverted.
5	InvTx2RFOff	Set to logic1 and Tx2RFEn set to logic 0, TX2 output signal is inverted.
4	InvTx1RFOff	Set to logic1 and Tx1RFEn set to logic 0, TX1 output signal is inverted.
3	Tx2CW	Set to logic 1, the output signal on pin TX2 will deliver continuously the un-modulated 13.56 MHz energy carrier. Set to logic 0, Tx2CW is enabled to modulate of the 13.56 MHz energy carrier.
2	CheckRF	Set to logic 1, Tx2RFEn and Tx1RFEn can not be set if an external RF field is detected. Only valid when using in combination with Tx2RFAutoEn and TX1RFAutoEn bits in CIU_TxAuto register.
1	Tx2RFEn	Set to logic 1, the output signal on pin TX2 will deliver the 13.56 MHz energy carrier modulated by the transmission data.
0	Tx1RFEn	Set to logic 1, the output signal on pin TX1 will deliver the 13.56 MHz energy carrier modulated by the transmission data.

8.6.23.21 CIU_TxAuto register (6305h)

Controls the setting of the antenna driver.

Table 214. CIU_TxAuto register (address 6305h) bit allocation

Bit	7	6	5	4	3	2	1	0
Symbol	Auto RFOFF	Force 100ASK	AutoWakeUp	-	CAOn	InitialRFOn	Tx2 RFAutoEn	Tx1 RFAutoEn
Reset	0	0	0	0	0	0	0	0
Access	R/W	R/W	R/W	R	R/W	W	R/W	R/W

Table 215. Description of CIU_TxAuto bits

Bit	Symbol	Description
7	AutoRFOff	Set to logic 1, own RF field is switched off after the last data bit has been transmitted as defined in the NFCIP-1 standard.
6	Force100ASK	Set to logic 1, Force100ASK forces a 100% ASK modulation independent of the setting in CIU_ModGsP register.
5	AutoWakeUp	Set to logic 1, the PN532 in CIU Power-down mode can be woken up by the RF level detector.
4		Reserved
3	CAOn	Set to logic 1, the collision avoidance is activated and internally the value n is set in accordance to the ISO/IEC 18092 / ECMA340 NFCIP-1 standards.
2	InitialRFOn	Set to logic 1, the initial RF collision avoidance is performed and the bit InitialRFOn is set to logic 0 automatically, if the RF is switched ON. Note: The driver(s) which should be switched on, have to be enabled by Tx2RFAutoEn and/or Tx1RFAutoEn bits. Note: If the own RF field is already ON when the bit InitialRFOn is set, it is not set to logic 0.
1	Tx2RFAutoEn	Set to logic 1, RF is switched on at TX2 (i.e. Tx2RFEn is set to logic 1) after the external RF field is switched off according to the time TADT. If the InitialRFOn and Tx2RFAutoEn bits are set to logic 1, RF is switched on at TX2 if no external RF field is detected during the time TIDT. Note: The times TADT and TIDT are in accordance to the ISO/IEC 18092 / ECMA340 NFCIP-1 standards.
0	Tx1RFAutoEn	Set to logic 1, RF is switched on at TX1 (i.e. Tx1RFEn is set to logic 1) after the external RF field is switched off according to the time TADT. If the InitialRFOn and Tx1RFAutoEn bits are set to logic 1, RF is switched on at TX1 if no external RF field is detected during the time TIDT. Note: The times TADT and TIDT are in accordance to the ISO/IEC 18092 / ECMA340 NFCIP-1 standards.

8.6.23.22 CIU_TxSel register (6306h)

Selects the sources for the analogue transmitter part

Table 216. CIU_TxSel register (address 6306h) bit allocation

Bit	7	6	5	4	3	2	1	0
Symbol	LoadModSel[1:0]		DriverSel[1:0]		SigOutSel[3:0]			
Reset	0	0	0	1	0	0	0	0
Access	R/W	R/W	R/W	R/W	R/W	R/W	R/W	R/W

Table 217. Description of CIU_TxSel bits

Bit	Symbol	Description																
7 to 6	LoadModSel[1:0]	Selects the signal to be output on LOADMOD <table border="1"> <thead> <tr> <th>Value</th> <th>Description</th> </tr> </thead> <tbody> <tr> <td>00</td> <td>Tristate</td> </tr> <tr> <td>01</td> <td>Modulation signal (envelope) from the internal coder</td> </tr> <tr> <td>10</td> <td>Modulation signal (envelope) from SIGIN</td> </tr> <tr> <td>11</td> <td>Test signal defined by LoadModtest in register CIU_TestSel1</td> </tr> </tbody> </table>	Value	Description	00	Tristate	01	Modulation signal (envelope) from the internal coder	10	Modulation signal (envelope) from SIGIN	11	Test signal defined by LoadModtest in register CIU_TestSel1						
Value	Description																	
00	Tristate																	
01	Modulation signal (envelope) from the internal coder																	
10	Modulation signal (envelope) from SIGIN																	
11	Test signal defined by LoadModtest in register CIU_TestSel1																	
5 to 4	DriverSel[1:0]	Selects the signals to be output on Tx1 and Tx2. <table border="1"> <thead> <tr> <th>Value</th> <th>Description</th> </tr> </thead> <tbody> <tr> <td>00</td> <td>Tristate</td> </tr> <tr> <td>01</td> <td>Modulation signal (envelope) from the internal coder</td> </tr> <tr> <td>10</td> <td>Modulation signal (envelope) from SIGIN</td> </tr> <tr> <td>11</td> <td>HIGH</td> </tr> </tbody> </table> <p>Note: The HIGH level depends on the setting of InvTx1RFON/InvTx1RFOff and InvTx2RFON/InvTx2RFOff.</p>	Value	Description	00	Tristate	01	Modulation signal (envelope) from the internal coder	10	Modulation signal (envelope) from SIGIN	11	HIGH						
Value	Description																	
00	Tristate																	
01	Modulation signal (envelope) from the internal coder																	
10	Modulation signal (envelope) from SIGIN																	
11	HIGH																	
3 to 0	SigOutSel[3:0]	Select the signal to be output on SIGOUT <table border="1"> <tbody> <tr> <td>0000</td> <td>Tristate</td> </tr> <tr> <td>0001</td> <td>Low</td> </tr> <tr> <td>0010</td> <td>High</td> </tr> <tr> <td>0011</td> <td>Test bus signal as defined by TestBusBitSel in CIU_TestSel1.</td> </tr> <tr> <td>0100</td> <td>Modulation signal (envelope) from the internal coder</td> </tr> <tr> <td>0101</td> <td>Serial data stream to be transmitted</td> </tr> <tr> <td>0110</td> <td>Output signal of the receiver circuit (card modulation signal regenerated and delayed). This signal is used as data output signal for secure IC interface connection using 3 lines. Note: To have a valid signal the CIU has to be set to the receiving mode by either the Transceive or Receive command. The RxMultiple bit can be used to keep the CIU in receiving mode. Note: Do not use this setting in ISO/IEC 14443A/MIFARE mode. Data collisions will not be transmitted on SIGOUT when using Manchester coding.</td> </tr> <tr> <td>0111</td> <td>Serial data stream received. Note: Do not use this setting in ISO/IEC 14443A/MIFARE mode. Miller coding parameters as the bitlength can vary</td> </tr> </tbody> </table>	0000	Tristate	0001	Low	0010	High	0011	Test bus signal as defined by TestBusBitSel in CIU_TestSel1.	0100	Modulation signal (envelope) from the internal coder	0101	Serial data stream to be transmitted	0110	Output signal of the receiver circuit (card modulation signal regenerated and delayed). This signal is used as data output signal for secure IC interface connection using 3 lines. Note: To have a valid signal the CIU has to be set to the receiving mode by either the Transceive or Receive command. The RxMultiple bit can be used to keep the CIU in receiving mode. Note: Do not use this setting in ISO/IEC 14443A/MIFARE mode. Data collisions will not be transmitted on SIGOUT when using Manchester coding.	0111	Serial data stream received. Note: Do not use this setting in ISO/IEC 14443A/MIFARE mode. Miller coding parameters as the bitlength can vary
0000	Tristate																	
0001	Low																	
0010	High																	
0011	Test bus signal as defined by TestBusBitSel in CIU_TestSel1.																	
0100	Modulation signal (envelope) from the internal coder																	
0101	Serial data stream to be transmitted																	
0110	Output signal of the receiver circuit (card modulation signal regenerated and delayed). This signal is used as data output signal for secure IC interface connection using 3 lines. Note: To have a valid signal the CIU has to be set to the receiving mode by either the Transceive or Receive command. The RxMultiple bit can be used to keep the CIU in receiving mode. Note: Do not use this setting in ISO/IEC 14443A/MIFARE mode. Data collisions will not be transmitted on SIGOUT when using Manchester coding.																	
0111	Serial data stream received. Note: Do not use this setting in ISO/IEC 14443A/MIFARE mode. Miller coding parameters as the bitlength can vary																	

Table 217. Description of CIU_TxSel bits ...continued

Bit	Symbol	Description
1000-1011		FeliCa secure IC modulation
	1000	RX*
	1001	TX
	1010	Demodulator comparator output
	1011	Reserved
<p>Note: * To have a valid signal the CIU has to be set to the receiving mode by either the Transceive or Receive commands. The bit RxMultiple can be used to keep the CIU in receiving mode</p>		
1000-1011		MIFARE secure IC modulation
	1100	RX* with RF carrier
	1101	TX with RF carrier
	1110	RX with RF carrier unfiltered
	1111	RX envelope unfiltered
<p>Note: * To have a valid signal the CIU has to be set to the receiving mode by either the Transceive or Receive commands. The bit RxMultiple can be used to keep the CIU in receiving mode</p>		

8.6.23.23 CIU_RxSel register (6307h)

Selects internal receiver settings.

Table 218. CIU_RxSel register (address 6307h) bit allocation

Bit	7	6	5	4	3	2	1	0
Symbol	UartSel[1:0]		RxWait[5:0]					
Reset	1	0	0	0	0	1	0	0
Access	R/W	R/W	R/W	R/W	R/W	R/W	R/W	R/W

Table 219. Description of CIU_RxSel bits

Bit	Symbol	Description										
7 to 6	UartSel[1:0]	Selects the input of the digital part (CL UART) of the CIU										
		<table border="1"> <thead> <tr> <th>Value</th> <th>Description</th> </tr> </thead> <tbody> <tr> <td>00</td> <td>Constant Low</td> </tr> <tr> <td>01</td> <td>Envelope signal at SIGIN</td> </tr> <tr> <td>10</td> <td>Modulation signal from the internal analog part</td> </tr> <tr> <td>11</td> <td>Modulation signal from SIGIN pin. Only valid for transfer speeds above 424 kbit/s</td> </tr> </tbody> </table>	Value	Description	00	Constant Low	01	Envelope signal at SIGIN	10	Modulation signal from the internal analog part	11	Modulation signal from SIGIN pin. Only valid for transfer speeds above 424 kbit/s
Value	Description											
00	Constant Low											
01	Envelope signal at SIGIN											
10	Modulation signal from the internal analog part											
11	Modulation signal from SIGIN pin. Only valid for transfer speeds above 424 kbit/s											
5 to 0	RxWait[5:0]	<p>After data transmission, the activation of the receiver is delayed for RxWait bit-clocks. During this ‘frame guard time’ any signal at pin Rx is ignored.</p> <p>This parameter is ignored by the Receive command. All other commands (e.g. Transceive, Autocoll, MFAuthent) use this parameter. Depending on the mode of the CIU, the counter starts differently. In Passive Communication mode the counters starts with the last modulation of the transmitted data stream. In Active Communication mode the counter starts immediately after the external RF field is switched on.</p>										

8.6.23.24 CIU_RxThreshold register (6308h)

Selects thresholds for the bit decoder.

Table 220. CIU_RxThreshold register (address 6308h) bit allocation

Bit	7	6	5	4	3	2	1	0
Symbol	MinLevel[3:0]			-	Collevel[2:0]			
Reset	1	0	0	0	0	1	0	0
Access	R/W	R/W	R/W	R/W	R	R/W	R/W	R/W

Table 221. Description of CIU_RxThreshold bits

Bit	Symbol	Description
7 to 4	MinLevel[3:0]	Defines the minimum signal strength at the decoder input that shall be accepted. If the signal strength is below this level, it is not evaluated.
3	-	Reserved
2 to 0	Collevel[2:0]	Defines the minimum signal strength at the decoder input that has to be reached by the weaker half-bit of the Manchester-coded signal to generate a bit-collision relatively to the amplitude of the stronger half-bit.

8.6.23.25 CIU_Demod register (6309h)

Defines demodulator settings.

Table 222. CIU_Demod register (address 6309h) bit allocation

Bit	7	6	5	4	3	2	1	0
Symbol	AddIQ[1:0]		FixIQ	-	TauRcv[1:0]		TauSync[1:0]	
Reset	0	1	0	0	1	1	0	1
Access	R/W	R/W	R/W	R	R/W	R/W	R/W	R/W

Table 223. Description of CIU_Demod bits

Bit	Symbol	Description
7 to 6	AddIQ[1:0]	Defines the use of I and Q channel during reception. Note: FixIQ has to be set to logic 0 to enable the following settings. ValueDescription 00Select the stronger channel 01Select the stronger and freeze the selected during communication 10Combines the I and Q channel 11RFU
5	FixIQ	If set to logic 1 and AddIQ[0] is set to logic 0, the reception is fixed to I channel. If set to logic 1 and AddIQ[0] is set to logic 1, the reception is fixed to Q channel.
4	-	Reserved
3 to 2	TauRcv[1:0]	Changes time-constant of internal PLL during data receiving. Note: If set to 00h, the PLL is frozen during data receiving.
1 to 0	TauSync[1:0]	Changes time-constant of internal PLL during burst (out of data reception)

8.6.23.26 CIU_FeINFC1 register (630Ah)

Defines the length of the FeliCa Sync bytes and the minimum length of the received frame.

Table 224. CIU_FeINFC1 register (address 630Ah) bit allocation

Bit	7	6	5	4	3	2	1	0
Symbol	FeISyncLen[1:0]		DataLenMin[5:0]					
Reset	0	0	0	0	0	0	0	0
Access	R/W	R/W	R/W	R/W	R/W	R/W	R/W	R/W

Table 225. Description of CIU_FeINFC1 bits

Bit	Symbol	Description										
7 to 6	FeISyncLen[1:0]]	Defines the length of the Sync bytes. <table border="1" style="margin-left: 20px;"> <thead> <tr> <th>Value</th> <th>Description</th> </tr> </thead> <tbody> <tr> <td>00</td> <td>B2 4D</td> </tr> <tr> <td>01</td> <td>00 B2 4D</td> </tr> <tr> <td>10</td> <td>00 00 B2 4D</td> </tr> <tr> <td>11</td> <td>00 00 00 B2 4D</td> </tr> </tbody> </table>	Value	Description	00	B2 4D	01	00 B2 4D	10	00 00 B2 4D	11	00 00 00 B2 4D
Value	Description											
00	B2 4D											
01	00 B2 4D											
10	00 00 B2 4D											
11	00 00 00 B2 4D											
5 to 0	DataLenMin[5:0]	These bits define the minimum length of the accepted frame length. $DataLenMin \times 4 \leq DataPacketLenght$ <p>This parameter is ignored at 106 kbit/s if the DetectSync bit in CIU_Mode register is set to logic 0. If a received frame is shorter as the defined DataLenMin value, the frame will be ignored.</p>										

8.6.23.27 CIU_FeINFC2 register (630Bh)

Defines the maximum length of the received frame.

Table 226. CIU_FeINFC2 register (address 630Bh) bit allocation

Bit	7	6	5	4	3	2	1	0
Symbol	WaitForSelected	ShortTimeSlot	DataLenMax[5:0]					
Reset	0	0	0	0	0	0	0	0
Access	R/W	R/W	R/W	R/W	R/W	R/W	R/W	R/W

Table 227. Description of CIU_FeINFC2 bits

Bit	Symbol	Description
7	WaitForSelected	<p>Set to logic 1, the AutoColl command is automatically ended only when:</p> <ol style="list-style-type: none"> 1. A valid command has been received after performing a valid Select procedure according to ISO/IEC 14443A. 2. A valid command has been received after performing a valid Polling procedure according to the FeliCa specification. <p>Note: If this bit is set, no Active Communication is possible.</p> <p>Note: Setting this bit reduces the 80C51 interaction in case of a communication to another device in the same RF field during Passive Communication mode.</p>
6	ShortTimeSlot	<p>Defines the time slot length for Active Communication mode at 424 kbit/s.</p> <p>Set to logic 1 a short time slot is used (half of the timeslot at 212 kbit/s).</p> <p>Set to logic 0 a long timeslot is used (equal to the timeslot for 212 kbit/s).</p>
5 to 0	DataLenMax[5:0]	<p>These bits define the maximum length of the accepted frame length:</p> $DataLenMax \times 4 \geq DataPacketLength$ <p>Note: If set to logic 0 the maximum data length is 256 bytes.</p> <p>This parameter is ignored at 106 kbit/s if the bit DetectSync in register CIU_Mode is set to logic 0.</p> <p>If a received frame is larger as the defined DataLenMax value, the frame will be ignored.</p>

8.6.23.28 CIU_MifNFC register (630Ch)

Defines ISO/IEC 14443A/MIFARE/NFC specific settings in target or card operating mode.

Table 228. CIU_MifNFC register (address 630Ch) bit allocation

Bit	7	6	5	4	3	2	1	0
Symbol	SensMiller[2:0]			TauMiller[1:0]		MFHalted	TxWait[1:0]	
Reset	0	1	1	0	0	0	1	0
Access	R/W	R/W	R/W	R/W	R/W	DY	R/W	R/W

Table 229. Description of CIU_MifNFC bits

Bit	Symbol	Description
7 to 5	SensMiller[2:0]	This bit defines the sensitivity of the Miller decoder.
4 to 3	TauMiller[1:0]	This bit defines the time constant of the Miller decoder.
2	MFHalted	Set to logic 1, this bit indicates that the CIU is set to HALT mode in Card Operating mode at 106 kbit/s. This bit is either set by the 80C51 or by the internal state machine and indicates that only the code 52h is accepted as a Request command. This bit is automatically set to logic 0 by RF reset.
1 to 0	TxWait[1:0]	In combination with TxBitPhase[6:0] in CIU_TxBitPhase register, defines the additional response time for the target at 106 kbit/s in Passive Communication mode and during the AutoColl command. See CIU_TxBitPhase register.

8.6.23.29 CIU_ManualRCV register (630Dh)

Allows manual fine tuning of the internal receiver.

IMPORTANT NOTE: For standard application it is not recommended to change this register settings.

Table 230. CIU_ManualRCV register (address 630Dh) bit allocation

Bit	7	6	5	4	3	2	1	0
Symbol	-	FastFiltMF_SO	DelayMF_SO	ParityDisable	LargeBWPLL	ManualHPCF	HPCF[1:0]	
Reset	0	0	0	0	0	0	0	0
Access	R	R/W	R/W	R/W	R/W	R/W	R/W	R/W

Table 231. Description of CIU_ManualRCV bits

Bit	Symbol	Description
7	-	Reserved
6	FastFiltMF_SO	<p>If this bit is set to logic 1, the internal filter for the Miller-Delay circuit is set to Fast-Mode</p> <p>Note: This bit should only be set to logic 1, if the Miller pauses length expected are less than 400 ns. At 106 kbit/s, the Miller pauses duration is around 3 μs.</p>
5	DelayMF_SO	<p>If this bit is set to logic 1, when SigoutSel=1100b (register 6306h), the Signal at SIGOUT-pin is delayed according the delay defined by TxBitPhase[6:0] (register 6315h) and TxWait bits (register 630Ch).</p> <p>Note: In ISO/IEC 14443A/MIFARE Card MIFARE 1 KB or MIFARE 4 KB emulation (Virtual Card) mode (DriverSel = 10b and SigoutSel=1110b), the Signal at SIGIN must then be 128 /fc faster compared to the ISO/IEC 14443A restrictions on the RF-Field for the Frame Delay Time.</p> <p>Note: This delay shall only be activated for setting bits SigOutSel to (1110b) or (1111b) in register CIU_TxSel.</p> <p>If this bit is set to logic 0, the SIGOUT-pin delay is not adjustable.</p> <p>Note: In ISO/IEC 14443A/MIFARE Card MIFARE 1 KB or MIFARE 4 KB emulation (Virtual Card) mode (DriverSel = 10b and SigoutSel=1110b), the ISO/IEC 14443A restrictions on the RF-Field for the Frame Delay Time should be adjusted on the secure IC side</p>
4	ParityDisable	<p>If this bit is set to logic 1, the generation of the Parity bit for transmission and the parity check for receiving is switched off. The received parity bit is handled like a data bit.</p>

Table 231. Description of CIU_ManualRCV bits ...continued

Bit	Symbol	Description										
3	LargeBWPLL	Set to logic 1, the bandwidth of the internal PLL for clock recovery is extended. Note: As the bandwidth is extended, the PLL filtering effect is weaker and the performance of the communication may be affected.										
2	ManualHPCF	Set to logic 0, the HPCF[1:0] bits are ignored and the HPCF[1:0] settings are adapted automatically to the receiving mode.										
1 to 0	HPCF[1:0]	Selects the High Pass Corner Frequency (HPCF) of the filter in the internal receiver chain <table border="1"> <thead> <tr> <th>Value</th> <th>Description</th> </tr> </thead> <tbody> <tr> <td>00</td> <td>For signals with frequency spectrum down to 106 kHz</td> </tr> <tr> <td>01</td> <td>For signals with frequency spectrum down to 212 kHz</td> </tr> <tr> <td>10</td> <td>For signals with frequency spectrum down to 424 kHz</td> </tr> <tr> <td>11</td> <td>For signals with frequency spectrum down to 848 kHz</td> </tr> </tbody> </table>	Value	Description	00	For signals with frequency spectrum down to 106 kHz	01	For signals with frequency spectrum down to 212 kHz	10	For signals with frequency spectrum down to 424 kHz	11	For signals with frequency spectrum down to 848 kHz
Value	Description											
00	For signals with frequency spectrum down to 106 kHz											
01	For signals with frequency spectrum down to 212 kHz											
10	For signals with frequency spectrum down to 424 kHz											
11	For signals with frequency spectrum down to 848 kHz											

8.6.23.30 CIU_TypeB register (630Eh)

Selects the specific settings for the ISO/IEC 14443B

Table 232. CIU_TypeB register (address 630Eh) bit allocation

Bit	7	6	5	4	3	2	1	0
Symbol	Rx SOFReq	Rx EOFReq	-	EOFSOF Width	NoTx SOF	NoTx EOF	TxEGT[1:0]	
Reset	0	0	0	0	0	0	0	0
Access	R/W	R/W	R	R/W	R/W	R/W	R/W	R/W

Table 233. Description of CIU_TypeB bits

Bit	Symbol	Description
7	RxSOFReq	If this bit is set to logic 1, the SOF is required. A datastream starting without SOF is ignored. If this bit is set to logic 0, a datastream with and without SOF is accepted. The SOF will be removed and not written into the FIFO.
6	RxEOFReq	If this bit is set to logic 1, the EOF is required. A datastream ending without EOF will generate a protocol error: ProtocolErr in the CIU_Error register will be set to logic 1. If this bit is set to logic 0, a datastream with and without EOF is accepted. The EOF will be removed and not written into the FIFO.
5	-	Reserved.
4	EOFSOFWidth	If this bit is set to logic 1, the SOF and EOF will have the maximum length defined in the ISO/IEC 14443B. If this bit is set to logic 0, the SOF and EOF will have the minimum length defined in the ISO/IEC 14443B.
3	NoTxSOF	If this bit is set to logic 1, the generation of the SOF is suppressed.
2	NoTxEOF	If this bit is set to logic 1, the generation of the EOF is suppressed.
1 to 0	TxEgt[1:0]	These bits define the length of the EGT, as defined in the ISO/IEC 14443B
	Value	Description
	00	0 bit
	01	1 bit
	10	2 bits
	11	3 bits

8.6.23.31 CIU_CRCResultMSB register (6311h)

Shows the actual MSB values of the CRC calculation.

Note: The CRC is split into two 8-bit registers. See also the CIU_CRCResultLSB register.

Note: Setting the bit MSBFirst in CIU_Mode register reverses the bit order, the byte order is not changed

Table 234. CIU_CRCResultMSB register (address 6311h) bit allocation

Bit	7	6	5	4	3	2	1	0
Symbol	CRCResultMSB[7:0]							
Reset	1	1	1	1	1	1	1	1
Access	R	R	R	R	R	R	R	R

Table 235. Description of CIU_CRCResultMSB bits

Bit	Symbol	Description
7 to 0	CRCResultMSB[7:0]	This register shows the actual value of the most significant byte of the CRC calculation. It is valid only if CRCReady bit in CIU_Status1 register is set to logic 1.

8.6.23.32 CIU_CRCResultLSB register (6312h)

Shows the actual LSB values of the CRC calculation.

Note: The CRC is split into two 8-bit registers. See also the CIU_CRCResultMSB register.

Note: Setting the bit MSBFirst in CIU_Mode register reverses the bit order, the byte order is not changed

Table 236. CIU_CRCResultLSB register (address 6312h) bit allocation

Bit	7	6	5	4	3	2	1	0
Symbol	CRCResultLSB[7:0]							
Reset	1	1	1	1	1	1	1	1
Access	R	R	R	R	R	R	R	R

Table 237. Description of CIU_CRCResultLSB bits

Bit	Symbol	Description
7 to 0	CRCResultLSB[7:0]	This register shows the actual value of the most significant byte of the CRC register. It is valid only if CRCReady bit in CIU_Status1 register is set to logic 1.

8.6.23.33 CIU_GsNOff register (6313h)

Selects the conductance for the N-driver of the antenna driver pins TX1 and TX2 when there is no RF generated by the PN532.

Table 238. CIU_GsNOff register (address 6313h) bit allocation

Bit	7	6	5	4	3	2	1	0
Symbol	CWGsNOff[3:0]				ModGsNOff[3:0]			
Reset	1	0	0	0	1	0	0	0
Access	R/W	R/W	R/W	R/W	R/W	R/W	R/W	R/W

Table 239. Description of CIU_GsNOff bits

Bit	Symbol	Description
7 to 4	CWGsNOff[3:0]	<p>The value of this register defines the conductance of the output N-driver during the time of no modulation and when there is no RF generated by the PN532 (neither Tx1RFEn nor Tx2RFEn is set to logic 1).</p> <p>Note: The conductance value is binary weighted.</p> <p>Note: During CIU Power-down mode, if DriverSel[1:0] is not equal to 01b, CWGsNOff[3] is set to logic 1. This is not readable in the register.</p> <p>Note: The value of the register is only used if no RF is generated by the driver, otherwise the value CWGsNOn in the CIU_GsNOn register is used.</p>
3 to 0	ModGsNOff[3:0]	<p>The value of this register defines the conductance of the output N-driver for the time of modulation and when there is no RF generated by the PN532 (neither Tx1RFEn nor Tx2RFEn is set to logic 1).</p> <p>This may be used to regulate the modulation index when doing load modulation.</p> <p>Note: The conductance value is binary weighted.</p> <p>Note: During CIU Power-down, if DriverSel[1:0] is not equal to 01b, ModGsNOff[3] is set to logic 1. This is not readable in the register.</p> <p>Note: The value of the register is only used if no RF is generated by the driver, otherwise the value ModGsNOn in the CIU_GsNOn register is used.</p>

8.6.23.34 CIU_ModWidth register (6314h)

Controls the setting of the modulation width.

Table 240. CIU_ModWidth register (address 6314h) bit allocation

Bit	7	6	5	4	3	2	1	0
Symbol	ModWidth[7:0]							
Reset	0	0	1	0	0	1	1	0
Access	R/W	R/W	R/W	R/W	R/W	R/W	R/W	R/W

Table 241. Description of CIU_ModWidth bits

Bit	Symbol	Description
7 to 0	ModWidth[7:0]	<p>These bits define the width of the Miller modulation as initiator in Active and Passive Communication mode as multiples of the carrier frequency ($\text{ModWidth}+1 / f_c$). The maximum value is half the bit period.</p> <p>Acting as a target in Passive Communication mode at 106 kbit/s or in Card Operating mode for ISO/IEC 14443A/MIFARE these bits are used to change the duty cycle of the subcarrier frequency.</p> <p>Number of cycles with low value: $\text{NCLV} = (\text{Modwidth modulo } 8)+1$</p> <p>Number of cycles with high value: $\text{NCHV} = 16 - \text{NCLV}$</p>

8.6.23.35 CIU_TxBitPhase register (6315h)

Adjust the bit phase at 106 kbit/s during transmission.

Table 242. CIU_TxBitPhase register (address 6315h) bit allocation

Bit	7	6	5	4	3	2	1	0
Symbol	RcvClkChange	TxBitPhase[6:0]						
Reset	1	0	0	0	0	1	1	1
Access	R/W	R/W	R/W	R/W	R/W	R/W	R/W	R/W

Table 243. Description of CIU_TxBitPhase bits

Bit	Symbol	Description
7	RcvClkChange	Set to logic 1, the demodulator's clock is derived from the external RF field.
6 to 0	TxBitPhase[6:0]	<p>TxBitPhase[6:0] in addition with TxWait bits (register 63 0Ch), define a delay to adjust the bit synchronization during Passive Communication mode at 106 kbit/s and in ISO/IEC 14443A/MIFARE Reader/Writer mode. TxBitPhase[6:0] are representing a delay in number of carrier frequency clock cycles.</p> <p>Note: The ranges to be used for TxWait[1:0] and TxBitPhase[6:0] are between: TXWait=01b and TxBitPhase = 1Bh (equivalent to an added delay of 20 clock cycles) and TXWait=01b and TxBitPhase = 7Fh (equivalent to an added delay of 120 clock cycles) TxWait=10b and TxBitPhase = 00h (equivalent to an added delay of 121 clock cycles) and TxWait=10b and TxBitPhase = 0Fh (equivalent to an added delay of 136 clock cycles)</p> <p>Note: The delay can vary depending of antenna circuits.</p> <p>Note: When DriverSel = 01b (the transmitter modulation input is coming from the internal coder), this delay is added to the waiting period before transmitting data in all communication modes.</p> <p>Note: When SigoutSel=1110b (CIU_TxSel register), and DelayMF_SO =1b (CIU_ManualRCV register), this delay is added on SIGOUT.</p> <p>Note: If the Signal at SIGIN is 128/fc faster compared to the ISO/IEC 14443A restrictions on the RF-Field for the Frame Delay Time, this delay is made so that if the FDT is correct when DriverSel = 01b, the same values of TxWait[1:0] and TxBitPhase[6:0] are also correct for this configuration when DriverSel = 10b (the transmitter modulation input is coming from SIGIN).</p>

8.6.23.36 CIU_RFCfg register (6316h)

Configures the receiver gain and RF level detector sensitivity.

Table 244. CIU_RFCfg register (address 6316h) bit allocation

Bit	7	6	5	4	3	2	1	0
Symbol	RFLevelAmp	RxGain[2:0]			RFLevel[3:0]			
Reset	0	1	0	0	1	0	0	0
Access	R/W	R/W	R/W	R/W	R/W	R/W	R/W	R/W

Table 245. Description of CIU_RFCfg bits

Bit	Symbol	Description																		
7	RFLevelAmp	Set to logic 1, this bit activates the RF level detector’s amplifier, see Section 8.6.8 “RF level detector” on page 115 .																		
6 to 4	RxGain[2:0]	This register defines the receivers signal voltage gain factor: <table border="1" style="margin-left: 20px;"> <thead> <tr> <th>Value</th> <th>Description</th> </tr> </thead> <tbody> <tr><td>000</td><td>18 dB</td></tr> <tr><td>001</td><td>23 dB</td></tr> <tr><td>010</td><td>18 dB</td></tr> <tr><td>011</td><td>23 dB</td></tr> <tr><td>100</td><td>33 dB</td></tr> <tr><td>101</td><td>38 dB</td></tr> <tr><td>110</td><td>43 dB</td></tr> <tr><td>111</td><td>48 dB</td></tr> </tbody> </table>	Value	Description	000	18 dB	001	23 dB	010	18 dB	011	23 dB	100	33 dB	101	38 dB	110	43 dB	111	48 dB
Value	Description																			
000	18 dB																			
001	23 dB																			
010	18 dB																			
011	23 dB																			
100	33 dB																			
101	38 dB																			
110	43 dB																			
111	48 dB																			
3 to 0	RFLevel[3:0]	Defines the sensitivity of the RF level detector, for description see Section 8.6.8 “RF level detector” on page 115 .																		

8.6.23.37 CIU_GsNOh register (6317h)

Selects the conductance for the N-driver of the antenna driver pins TX1 and TX2 when generating RF.

Table 246. CIU_GsNOh register (address 6317h) bit allocation

Bit	7	6	5	4	3	2	1	0
Symbol	CWGsNOh[3:0]				ModGsNOh[3:0]			
Reset	1	0	0	0	1	0	0	0
Access	R/W	R/W	R/W	R/W	R/W	R/W	R/W	R/W

Table 247. Description of CIU_GsNOh bits

Bit	Symbol	Description
7 to 4	CWGsnOn[3:0]	<p>The value of this register defines the conductance of the output N-driver. during times of no modulation and when the PN532 generates the RF field.</p> <p>This may be used to regulate the output power and subsequently current consumption and operating distance.</p> <p>Note: The conductance value is binary weighted.</p> <p>Note: During CIU Power-down mode, if DriverSel[1:0] is not equal to 01b, CWGsNOh[3] is set to logic 1. This is not readable in the register.</p> <p>Note: The value of the register is only used if RF is generated by the driver (either Tx1RFEn or Tx2RFEn is set to logic 1), otherwise the value CWGsNOff in the register CIU_GsNOff is used.</p>
3 to 0	ModGsNOh[3:0]	<p>The value of this register defines the conductance of the output N-driver for the time of modulation and when the PN532 generates the RF field.</p> <p>This may be used to regulate the modulation index.</p> <p>Note: The conductance value is binary weighted.</p> <p>Note: During CIU Power-down mode, if DriverSel[1:0] is not equal to 01b, ModGsNOh[3] is set to logic 1. This is not readable in the register.</p> <p>Note: The value of the register is only used if RF is generated by the driver (either Tx1RFEn or Tx2RFEn is set to logic 1), otherwise the value ModGsNOff in the register CIU_GsNOff is used.</p>

8.6.23.38 CIU_CWGsP register (6318h)

Defines the conductance of the P-driver.

Table 248. CIU_CWGsP register (address 6318h) bit allocation

Bit	7	6	5	4	3	2	1	0
Symbol	-	-	CWGsP[5:0]					
Reset	0	0	1	0	0	0	0	0
Access	R	R	R/W	R/W	R/W	R/W	R/W	R/W

Table 249. Description of CIU_CWGsP bits

Bit	Symbol	Description
7 to 6	-	Reserved.
5 to 0	CWGsP[5:0]	<p>The value of this register defines the conductance of the output P-driver, during times of no modulation.</p> <p>This may be used to regulate the output power and subsequently current consumption and operating distance.</p> <p>Note: The conductance value is binary weighted.</p> <p>Note: During CIU Power-down mode, if DriverSel[1:0] is not equal to 01b, CWGsP[5] is set to logic 1. This is not readable in the register.</p>

8.6.23.39 CIU_ModGsP register (6319h)

Defines the driver P-output conductance for the time of modulation.

Table 250. CIU_ModGsP register (address 6319h) bit allocation

Bit	7	6	5	4	3	2	1	0
Symbol	-	-	ModGsP[5:0]					
Reset	0	0	1	0	0	0	0	0
Access	R	R	R/W	R/W	R/W	R/W	R/W	R/W

Table 251. Description of CIU_ModGsP bits

Bit	Symbol	Description
7 to 6	-	Reserved.
5 to 0	ModGsP[5:0]	<p>The value of this register defines the conductance of the output P-driver for the time of modulation.</p> <p>This may be used to regulate the modulation index.</p> <p>Note: The conductance value is binary weighted.</p> <p>Note: During CIU Power-down mode, if DriverSel[1:0] is not equal to 01b, ModGsP[5] is set to logic 1. This is not readable in the register.</p> <p>Note: If Force100ASK in CIU_TxAuto register is set to logic 1, the ModGsP[5:0] setting has no effect.</p>

8.6.23.40 CIU_TMode register (631Ah)

Defines settings for the internal timer.

Table 252. CIU_TMode register (address 631Ah) bit allocation

Bit	7	6	5	4	3	2	1	0
Symbol	TAuto	TGated[1:0]		TAutoRestart	TPrescaler_Hi[3:0]			
Reset	0	0	0	0	0	0	0	0
Access	R/W	R/W	R/W	R/W	R/W	R/W	R/W	R/W

Table 253. Description of CIU_TMode bits

Bit	Symbol	Description										
7	TAuto	<p>Set to logic 1, the timer starts automatically at the end of the transmission in all communication modes at all speed, or when InitialRFOn (in CIU_TxAuto) is set to logic 1 and the external RF field is switched on. The timer stops immediately after receiving the first data bit if RxMultiple in the CIU_RxMode register is set to logic 0. If RxMultiple is set to logic 1, the timer never stops. In this case the timer can be stopped by setting the bit TStopNow in register CIU_Control to 1.</p> <p>Set to logic 0 indicates, that the timer is not influenced by the protocol.</p>										
6 to 5	TGated[1:0]	<p>The internal timer is running in gated mode.</p> <p>Note: In the gated mode, the bit TRunning is logic 1 when the timer is enabled by the register bits. This bit does not influence the gating signal</p> <table border="1"> <thead> <tr> <th>Value</th> <th>Description</th> </tr> </thead> <tbody> <tr> <td>00</td> <td>No gated mode</td> </tr> <tr> <td>01</td> <td>Gated by SIGIN</td> </tr> <tr> <td>10</td> <td>Gated by AUX1</td> </tr> <tr> <td>11</td> <td>Reserved</td> </tr> </tbody> </table>	Value	Description	00	No gated mode	01	Gated by SIGIN	10	Gated by AUX1	11	Reserved
Value	Description											
00	No gated mode											
01	Gated by SIGIN											
10	Gated by AUX1											
11	Reserved											
4	TAutoRestart	<p>Set to logic 1 the timer automatically restart its count-down from TReloadValue defined within when reaches zero.</p> <p>Set to logic 0 the timer decrements to zero and the bit TimerIRq is set to logic 1.</p>										
3 to 0	TPrescaler_Hi[3:0]	<p>Defines higher 4 bits for the TPrescaler.</p> <p>The following formula is used to calculate f_{Timer}:</p> $f_{Timer} = 6.78MHz / T_{PreScaler}$ <p>For detailed description see Section 8.6.17 “CIU_timer” on page 129.</p> <p>Note: TPreScaler is defined with TPreScaler_Hi[3:0] in this register and TPreScaler_LO[7:0] in CIU_TPrescaler.</p>										

8.6.23.41 CIU_TPrescaler register (631Bh)

Define the LSB of the Timer-Prescaler.

Table 254. CIU_TPrescaler register (address 631Bh) bit allocation

Bit	7	6	5	4	3	2	1	0
Symbol	TPrescaler_LO[7:0]							
Reset	0	0	0	0	0	0	0	0
Access	R/W	R/W	R/W	R/W	R/W	R/W	R/W	R/W

Table 255. Description of CIU_TPrescaler bits

Bit	Symbol	Description
-----	--------	-------------

7 to 0 TPrescaler_LO[7:0] Defines lower 8 bits for TPrescaler.

The following formula is used to calculate f_{Timer}

$$f_{Timer} = 6.78MHz / T_{PreScaler}$$

For detailed description see [Section 8.6.17 “CIU_timer” on page 129](#).

Note: The TPreScaler time is defined with TPreScaler_Hi[3:0] in CIU_TMode and TPreScaler_LO[7:0] in this register.

8.6.23.42 CIU_TReload_hi register (631Ch)

Defines the MSB of the 16-bit long timer reload value.

Table 256. CIU_TReloadVal_hi register (address 631Ch) bit allocation

Bit	7	6	5	4	3	2	1	0
Symbol	TReloadVal_Hi[7:0]							
Reset	0	0	0	0	0	0	0	0
Access	R/W	R/W	R/W	R/W	R/W	R/W	R/W	R/W

Table 257. Description of CIU_TReloadVal_hi bits

Bit	Symbol	Description
-----	--------	-------------

7 to 0 TReloadVal_Hi[7:0] Defines the higher 8 bits for the TReloadValue.

With a start event the timer loads with the TReloadValue. Changing this register affects the timer only with the next start event.

Note: The reload value is defined with TReloadVal_Hi[7:0] in this register and TReloadVal_Lo[7:0] in CIU_TReloadVal_lo

8.6.23.43 CIU_TReloadVal_lo register (631Dh)

Defines the LSB of the 16 bit long timer reload value.

Table 258. CIU_TReload_lo register (address 631Dh) bit allocation

Bit	7	6	5	4	3	2	1	0
Symbol	TReloadVal_Lo[7:0]							
Reset	0	0	0	0	0	0	0	0
Access	R/W	R/W	R/W	R/W	R/W	R/W	R/W	R/W

Table 259. Description of CIU_TReload_lo bits

Bit	Symbol	Description
7 to 0	TReloadVal_Lo[7:0]	Defines the lower 8 bits for the TReloadValue. With a start event the timer loads with the TReloadValue. Changing this register affects the timer only with the next start event. Note: The reload value is defined with TReloadVal_Lo[7:0] in this register and TReloadVal_Hi[7:0] in CIU_TReload_Hi.

8.6.23.44 CIU_TCounterVal_hi register (631Eh)

Defines the MSB byte of the current value of the timer.

Table 260. CIU_TCounterVal_hi register (address 631Eh) bit allocation

Bit	7	6	5	4	3	2	1	0
Symbol	TCounterVal_Hi[7:0]							
Reset	x	x	x	x	x	x	x	x
Access	R	R	R	R	R	R	R	R

Table 261. Description of CIU_TCounterVal_hi bits

Bit	Symbol	Description
7 to 0	TCounterVal_Hi[7:0]	MSB of the current value of the timer (Higher 8 bits).

8.6.23.45 Register CIU_TCounterVal_lo (631Fh)

Defines the LSB byte of the current value of the timer.

Table 262. CIU_TCounterVal_lo register (address 631Fh) bit allocation

Bit	7	6	5	4	3	2	1	0
Symbol	TCounterVal_LO[7:0]							
Reset	x	x	x	x	x	x	x	x
Access	R	R	R	R	R	R	R	R

Table 263. Description of CIU_TCounterVal_lo bits

Bit	Symbol	Description
7 to 0	TCounterVal_LO[7:0]	LSB of the current value of the timer (Lower 8 bits).

8.6.23.46 CIU_TestSel1 register (6321h)

General test signal configuration.

Table 264. CIU_TestSel1 register (address 6321h) bit allocation

Bit	7	6	5	4	3	2	1	0
Symbol	LoadModTst[1:0]		SICcksel[1:0]		SICClkD1	TstBusBitSel[2:0]		
Reset	0	0	0	0	0	0	0	0
Access	R/W	R/W	R/W	R/W	R/W	R/W	R/W	R/W

Table 265. Description of CIU_TestSel1 bits

Bit	Symbol	Description										
7 to 6	LoadModTst[1:0]	<p>Defines the test signal for the LOADMOD pin</p> <p>Note: The bits LoadModSel in register CIU_TxSel has to be set to logic 1 to enable LoadModTst:</p> <table border="1"> <thead> <tr> <th>Value</th> <th>Description</th> </tr> </thead> <tbody> <tr> <td>00</td> <td>Low</td> </tr> <tr> <td>01</td> <td>High</td> </tr> <tr> <td>10</td> <td>RFU</td> </tr> <tr> <td>11</td> <td>TstBusBit as defined by the TestBusBitSel bit of this register</td> </tr> </tbody> </table>	Value	Description	00	Low	01	High	10	RFU	11	TstBusBit as defined by the TestBusBitSel bit of this register
Value	Description											
00	Low											
01	High											
10	RFU											
11	TstBusBit as defined by the TestBusBitSel bit of this register											
5 to 4	SICcksel[1:0]	<p>Defines the source for the 13.56 MHz secure IC clock</p> <table border="1"> <thead> <tr> <th>Value</th> <th>Description</th> </tr> </thead> <tbody> <tr> <td>00</td> <td>GND - secure IC clock is switched off</td> </tr> <tr> <td>01</td> <td>Clock derivated by the internal oscillator</td> </tr> <tr> <td>10</td> <td>Internal CIU clock</td> </tr> <tr> <td>11</td> <td>Clock derivated from the RF Field</td> </tr> </tbody> </table>	Value	Description	00	GND - secure IC clock is switched off	01	Clock derivated by the internal oscillator	10	Internal CIU clock	11	Clock derivated from the RF Field
Value	Description											
00	GND - secure IC clock is switched off											
01	Clock derivated by the internal oscillator											
10	Internal CIU clock											
11	Clock derivated from the RF Field											
3	SICClkD1	Set to logic 1, the secure IC clock is delivered to P31 / UART_TX if the observe_ciu bit is set to logic 1.										
2 to 0	TstBusBitSel[2:0]	Select the TstBusBit from the test bus.										

8.6.23.47 CIU_TestSel2 register (6322h)

General test signal configuration and PRBS control.

Table 266. CIU_TestSel2 register (address 6322h) bit allocation

Bit	7	6	5	4	3	2	1	0
Symbol	TstBusFlip	PRBS9	PRBS15	TstBusSel[4:0]				
Reset	0	0	0	0	0	0	0	0
Access	R/W	R/W	R/W	R/W	R/W	R/W	R/W	R/W

Table 267. Description of CIU_TestSel2 bits

Bit	Symbol	Description
7	TstBusFlip	If set to logic 1, the internal test bus(D6-D0) is mapped to the external test bus pins by the following order: D4,D3, D2,D6,D5, D0, D1. See Section 8.6.21.2 “CIU test bus” on page 140 .
6	PRBS9	Starts and enables the PRBS9 sequence according ITU-TO150. Note: All relevant register to transmit data have to be configured before entering PRBS9 mode. Note: The data transmission of the defined sequence is started by the Transmit command.
5	PRBS15	Starts and enables the PRBS15 sequence according ITU-TO150. Note: All relevant register to transmit data have to be configured before entering PRBS15 mode. Note: The data transmission of the defined sequence is started by the Transmit command.
4 to 0	TstBusSel[4:0]	Selects the test bus source. See Section 8.6.21.2 “CIU test bus” on page 140 .

8.6.23.48 CIU_TestPinEn register (6323h)

Enable the output drivers for the test pins.

Table 268. CIU_TestPinEn register (address 6323h) bit allocation

Bit	7	6	5	4	3	2	1	0
Symbol	TestPinEn[7:0]							
Reset	0	0	0	0	0	0	0	0
Access	R/W	R/W	R/W	R/W	R/W	R/W	R/W	R/W

Table 269. Description of CIU_TestPinEn bits

Bit	Symbol	Description
7 to 0	TestPinEn[7:0]	Each of the bit enables the output driver for an internal test pin: P70_IRQ (MSB), RSTOUT_N, P35, P34 / SIC_CLK, P33_INT1, P32_INT0, P31 / UART_TX, P30 / UART_RX (LSB). DataEn[7] enables P70_IRQ, DataEn[0] enables P30 / UART_RX. Note: The data transmission of the defined sequence is started by the Transmit command.

8.6.23.49 CIU_TestPinValue register (6324h)

Defines the values for the 7 bit test bus signals to be I/O on P70_IRQ, RSTOUT_N, P35, P34 / SIC_CLK, P33_INT1, P32_INT0, P31 / UART_TX and P30 / UART_RX pins.

Table 270. CIU_TestPinValue register (address 6324h) bit allocation

Bit	7	6	5	4	3	2	1	0
Symbol	useio	TestPinValue[6:0]						
Reset	0	0	0	0	0	0	0	0
Access	R/W	R/W	R/W	R/W	R/W	R/W	R/W	R/W

Table 271. Description of CIU_TestPinValue bits

Bit	Symbol	Description
7	useio	Set to logic 1, this bit enables the I/O functionality for the internal test bus on the pins P70_IRQ (MSB), RSTOUT, P35, P34 / SIC_CLK, P33_INT1, P32_INT0, P31 / UART_TX, P30 / UART_RX (LSB) Note: Before using P34 / SIC_CLK as a test output, the SVDD switch should be closed. See register address 6106h.
6 to 0	TestPinValue[6:0]	UseIO set to logic 1, Read or write the value of the test bus. UseIO set to logic 0, Read 000_0000. No write.

8.6.23.50 CIU_TestBus register (6325h)

Shows the status of the internal test bus.

Table 272. CIU_TestBus register (address 6325h) bit allocation

Bit	7	6	5	4	3	2	1	0
Symbol	TestBus[7:0]							
Reset	x	x	x	x	x	x	x	x
Access	R	R	R	R	R	R	R	R

Table 273. Description of CIU_TestBus bits

Bit	Symbol	Description
7 to 0	TestBus[7:0]	Shows the status of the internal test bus. The test bus is selected by the register CIU_TestSel2. See Section 8.6.21.2 "CIU test bus" on page 140 .

8.6.23.51 CIU_AutoTest register (6326h)

Controls the digital self-test.

Table 274. CIU_AutoTest register (address 6326h) bit allocation

Bit	7	6	5	4	3	2	1	0
Symbol	-	AmpRcv	-	-	SelfTest[3:0]			
Reset	0	1	0	0	0	0	0	0
Access	R	R	R	R	R/W	R/W	R/W	R/W

Table 275. Description of CIU_AutoTest bits

Bit	Symbol	Description
7	-	Reserved.
6	AmpRcv	Set to logic 1 the internal signal processing in the receiver chain is performed non-linear. This increases the operating distance in communication modes at 106 kbit/s. Note: Due to non linearity the effects of MinLevel and CollLevel in CIU_RxThreshold register are as well non linear.
5 to 4	-	Reserved
3 to 0	SelfTest[3:0]	Enables the digital Self Test. The self-test can be started by the Selftest command in the CIU_Command register. The self-test is enabled by 1001. Note: For default operation the self-test has to be disabled (0000).

8.6.23.52 CIU_Version register (6327h)

Shows the version of the CIU.

Table 276. CIU_Version register (address 6327h) bit allocation

Bit	7	6	5	4	3	2	1	0
Symbol	Product[3:0]				Version[3:0]			
Reset	1	0	0	0	0	0	0	0
Access	R	R	R	R	R	R	R	R

Table 277. Description of CIU_Version bits

Bit	Symbol	Description
7 to 4	Product	Product 1000 (PN532)
3 to 0	Version	Version 0000

8.6.23.53 CIU_AnalogTest register (6328h)

Controls the pins AUX1 and AUX2.

Table 278. CIU_AnalogTest register (address 6328h) bit allocation

Bit	7	6	5	4	3	2	1	0
Symbol	AnalogSelAux1[3:0]				AnalogSelAux2[3:0]			
Reset	0	0	0	0	0	0	0	0
Access	R/W	R/W	R/W	R/W	R/W	R/W	R/W	R/W

Table 279. Description of CIU_AnalogTest bits

Bit	Symbol	Description
7 to 4	AnalogSelAux1[3:0]	Controls the AUX1 pin. Note: All test signals are described in Section 8.6.21.3 “Test signals at pin AUX” on page 141 .
		0000 Tristate
		0001 DAC output: register CIU_TestDAC1[1]
		0010 DAC output: test signal corr1[1]
		0011 DAC output: test signal corr2[1]
		0100 DAC output: test signal MinLevel[1]
		0101 DAC output: ADC_I[1]
		0110 DAC output: ADC_Q[1]
		0111 DAC output: ADC_I combined with ADC_Q[1]
		1000 Test signal for production test
		1001 secure IC clock
		1010 ErrorBusBit as described in Table 177 on page 144
		1011 Low
		1100 TxActive At 106 kbit/s: High during Start bit, Data bits, Parity and CRC At 212 kbit/s and 424 kbit/s: High during Preamble, Sync, Data bits and CRC
		1101 RxActive At 106 kbit/s: High during Data bits, Parity and CRC At 212 kbit/s and 424 kbit/s: High during Data bits and CRC
		1110 Subcarrier detected At 106 kbit/s: not applicable At 212 kbit/s and 424 kbit/s: High during last part of preamble, Sync, Data bits and CRC.
		1111 Test bus bit as defined by the TstBusBitSel in Table 265 on page 180

Table 279. Description of CIU_AnalogTest bits ...continued

Bit	Symbol	Description
3 to 0	AnalogSelAux2[3:0]	Controls the AUX2 pin. Note: All test signals are described in Section 8.6.21.3 “Test signals at pin AUX” on page 141 .
	0000	Tristate
	0001	DAC output: register CIU_TestDAC2 ^[2]
	0010	DAC output: test signal corr1 ^[2]
	0011	DAC output: test signal corr2 ^[2]
	0100	DAC output: test signal MinLevel ^[2]
	0101	DAC output: ADC_I ^[2]
	0110	DAC output: ADC_Q ^[2]
	0111	DAC output: ADC_I combined with ADC_Q ^[2]
	1000	Test signal for production test
	1001	secure IC clock
	1010	ErrorBusBit as described in Table 177 on page 144
	1011	Low
	1100	TxActive At 106 kbit/s: High during Start bit, Data bits, Parity and CRC At 212 kbit/s and 424 kbit/s: High during Preamble, Sync, Data bits and CRC
	1101	RxActive At 106 kbit/s: High during Data bits, Parity and CRC At 212 kbit/s and 424 kbit/s: High during Data bits and CRC
	1110	Subcarrier detected At 106 kbit/s: not applicable At 212 kbit/s and 424 kbit/s: High during last part of preamble, Sync, Data bits and CRC.
	1111	Test bus bit as defined by the TstBusBitSel in Table 264 on page 180

[1] Current output. The use of 1 k Ω pull down resistor on AUX1 is recommended.

[2] Current output. The use of 1 k Ω pull down resistor on AUX2 is recommended.

8.6.23.54 CIU_TestDAC1 register (6329h)

Defines the test value for TestDAC1.

Table 280. CIU_TestDAC1 register (address 6329h) bit allocation

Bit	7	6	5	4	3	2	1	0
Symbol	-	-	TestDAC1[5:0]					
Reset	0	0	X	X	X	X	X	X
Access	R	R	R/W	R/W	R/W	R/W	R/W	R/W

Table 281. Description of CIU_TestDAC1 bits

Bit	Symbol	Description
7 to 6	-	Reserved.
5 to 0	TestDAC1[5:0]	Defines the test value for TestDAC1. The output of the DAC1 can be switched to AUX1 by setting AnalogSelAux1 to 0001 in the CIU_AnalogTest register.

8.6.23.55 CIU_TestDAC2 register (632Ah)

Defines the test value for TestDAC2.

Table 282. CIU_TestDAC2 register (address 632Ah) bit allocation

Bit	7	6	5	4	3	2	1	0
Symbol	-	-	TestDAC2[6:0]					
Reset	0	0	X	X	X	X	X	X
Access	R	R	R/W	R/W	R/W	R/W	R/W	R/W

Table 283. Description of CIU_TestDAC2 bits

Bit	Symbol	Description
7 to 6	-	Reserved.
5 to 0	TestDAC2[6:0]	Defines the test value for TestDAC2. The output of the DAC2 can be switched to AUX2 by setting AnalogSelAux2 to 0001 in the CIU_AnalogTest register.

8.6.23.56 CIU_TestADC register (632Bh)

Shows the actual value of ADC I and Q channel.

Table 284. CIU_TestADC register (address 632Bh) bit allocation

Bit	7	6	5	4	3	2	1	0
Symbol	ADC_I[3:0]			ADC_Q[3:0]				
Reset	X	X	X	X	X	X	X	X
Access	R	R	R	R	R	R	R	R

Table 285. Description of CIU_TestADC bits

Bit	Symbol	Description
7 to 4	ADC_I[3:0]	Shows the actual value of ADC I channel.
3 to 0	ADC_Q[3:0]	Shows the actual value of ADC Q channel.

8.6.23.57 CIU_RFlevelDet register (632Fh)

Power down of the RF level detector.

Table 286. CIU_RFlevelDet register (address 632Fh) bit allocation

Bit	7	6	5	4	3	2	1	0
Symbol	-	-	-	pd_rflvldet	-	-	-	-
Reset	0	0	0	0	0	0	0	0
Access	R/W	R/W	R/W	R/W	R/W	R/W	R/W	R/W

Table 287. Description of CIU_RFlevelDet bits

Bit	Symbol	Description
7 to 5	-	Reserved. These bits must be set to logic 0.
4	pd_rfleveldet	Power down of the RF level detector. When set to logic 1, the RF level detector is in power down mode.
3 to 0	-	Reserved. These bits must be set to logic 0.

8.7 Registers map

8.7.1 Standard registers

Table 288. Standard registers mapping

Register address	Register name	Bit7	Bit6	Bit5	Bit4	Bit3	Bit2	Bit1	Bit0	
6000h to 6102h	Reserved									
6103h	Config I0_I1	int1_pol	Reserved	pad_I1	Reserved	pad_I0	enselif	Selif[1:0]		
6104h	Observe_testbus	Reserved							observe_ciu	
6105h	Data_rng	data_rng								
6106h	Control_switch_rng	Reserved	hide_svdd_sig	sic_switch_overload	sic_switch_en	Reserved	cpu_need_rng	random_dataready	Reserved	
6107h	GPIRQ	gpirq_level_P71	gpirq_level_P50	gpirq_level_P35	gpirq_level_P34	gpirq_enable_P71	gpirq_enable_P50	gpirq_enable_P35	gpirq_enable_P34	
6108h	Reserved									
6109h	LDO	Reserved		overcurrent_status	sel_overcurrent[1:0]		enoffset	soft_highspeedreg	control_highspeedreg	
610Ah	i2c_wu_control	Reserved					i2c_wu_en_wr	i2c_wu_en_rd	i2c_wu_en	
610Bh	Reserved									
610Ch	Andet_control	andet_bot	andet_up	andet_ith[1:0]		andet_ithh[2:0]		andet_en		
610Dh	Reserved									
610Eh	NFC_WI_control	Reserved				nfc_wi_status	Reserved	nfc_wi_en_act_req_im	nfc_wi_en_clk	
610Fh to 61FFh	Reserved									
6200h	PCR CFR	Reserved						cpu_freq[1:0]		
6201h	PCR CER	Reserved				hsu_enable	Reserved			
6202h	PCR ILR	Reserved	porpulse_latched	Reserved	enable_pdselfif	Reserved	gpirq_level	int1_level	int0_level	
6203h	PCR Control	Reserved							clear_wakeup_cond	soft_reset
6204h	PCR Status	i2c_wu	gpirq_wu	SPI_wu	HSU_wu	CIU_wu	Reserved	int1_wu	int0_wu	
6205h	PCR Wakeupen	i2c_wu_en	GPIRQ_wu_en	SPI_on_en	HSU_on_en	CIU_wu_en	Reserved	int1_en	int0_en	
6206h to 6300h	Reserved									
6301h	CIU_Mode	MSBFirst	DetectSync	TXWaitRF	RxWaitRF	PolSigin	ModeDetOff	CRCPreset[1:0]		
6302h	CIU_TxMode	TxCRCEn	TxSpeed[2:0]			InvMod	TxMix	TxFraming[1:0]		
6303h	CIU_RxMode	RXCRCEn	RxSpeed[2:0]			RxNoErr	RxMultiple	RxFraming[1:0]		
6304h	CIU_TxControl	InvTx2RFon	InvTx1RFon	InvTx2RFOff	InvTx1RFOff	Tx2CW	CheckRF	Tx2RFEn	Tx1RFEn	
6305h	CIU_TxAuto	AutoRFOFF	Force100ASK	AutoWakeUp	Reserved	CAOn	InitialRFOn	Tx2RFAutoEn	Tx1RFAutoEn	
6306h	CIU_TxSel	LoadModSel[1:0]		DriverSel[1:0]		SigOutSel[3:0]				
6307h	CIU_RxSel	UartSel[1:0]		RxWait[5:0]						
6308h	CIU_RxThreshold	MinLevel[3:0]				Reserved	Collevel[2:0]			
6309h	CIU_Demod	AddIQ[1:0]		FixIQ	Reserved	TauRcv[1:0]		TauSync[1:0]		
630Ah	CIU_FeINFC1	FelSyncLen[1:0]			DataLenMin[5:0]					
630Bh	CIU_FeINFC2	WaitForSelected	ShortTimeSlot	DataLenMax[5:0]						
630Ch	CIU_MifNFC	SensMiller[2:0]			TauMiller[1:0]		MFHalted	TxWait[1:0]		

Table 288. Standard registers mapping ...continued

Register address	Register name	Bit7	Bit6	Bit5	Bit4	Bit3	Bit2	Bit1	Bit0	
630Dh	CIU_ManualRCV	Reserved	FastFiltMF_SO	DelayMF_SO	ParityDisable	LargeBWPLL	ManualHPCF	HPCF[1:0]		
630Eh	CIU_TypeB	RxSOFReq	RxEOFReq	Reserved	EOFSOFWidth	NoTxSOF	NoTxEOF	TxEGT[1:0]		
630Fh to 6310h	Reserved									
6311h	CIU_CRCResultMSB					CRCResultMSB[7:0]				
6312h	CIU_CRCResultLSB									CRCResultLSB[7:0]
6313h	CIU_GsNOff	CWGsNOff[3:0]				ModGsNOff[3:0]				
6314h	CIU_ModWidth									ModWidth[7:0]
6315h	CIU_TxBitPhase	RcvClkChange							TxBitPhase[6:0]	
6316h	CIU_RFCfg	RFLevelAmp	RxGain[2:0]			RFLevel[3:0]				
6317h	CIU_GsNOn	CWGsNOn[3:0]				ModGsNOn[3:0]				
6318h	CIU_CWGsP	Reserved			CWGsP[5:0]					
6319h	CIU_ModGsP	Reserved			ModGsP[5:0]					
631Ah	CIU_TMode	TAuto	TGated[1:0]		TAutoRestart	TPrescaler_Hi[3:0]				
631Bh	CIU_TPrescaler									TPrescaler_LO[7:0]
631Ch	CIU_TReloadVal_Hi									TReloadVal_Hi[7:0]
631Dh	CIU_TReloadVal_Lo									TReloadVal_Lo[7:0]
631Eh	CIU_TCounterVal_hi									TCounterVal_Hi[7:0]
631Fh	CIU_TCounterVal_lo									TCounterVal_LO[7:0]
6320h	Reserved									
6321h	CIU_TestSel1	LoadModTst[1:0]		SICcksel[1:0]		SICckD1	TstBusBitSel[2:0]			
6322h	CIU_TestSel2	TstBusFlip	PRBS9	PRBS15	TstBusSel[4:0]					
6323h	CIU_TestPinEn									TestPinEn[7:0]
6324h	CIU_TestPinValue	useio	TestPinValue[6:0]							
6325h	CIU_TestBus									TestBus[7:0]
6326h	CIU_AutoTest	Reserved	AmpRcv	Reserved			SelfTest[3:0]			
6327h	CIU_Version	Product					Version			
6328h	CIU_AnalogTest	AnalogSelAux1[3:0]					AnalogSelAux2[3:0]			
6329h	CIU_TestDAC1	Reserved			TestDAC1[5:0]					
632Ah	CIU_TestDAC2	Reserved			TestDAC2[5:0]					
632Bh	CIU_TestADC	ADC_I[3:0]				ADC_Q[3:0]				
632Ch to 632Eh	Reserved									
632Fh	CIU_RFlevelDet	Reserved			pd_rfleveldet	Reserved				
6330h	SIC_CLK	sic_clk_p34_en	Reserved			Errorbusbitenable	ErrorbusbitSel[2:0]			
6331h	CIU_Command				RcvOff	Power-down	Command			

Table 288. Standard registers mapping ...continued

Register address	Register name	Bit7	Bit6	Bit5	Bit4	Bit3	Bit2	Bit1	Bit0
6332h	CIU_CommlEn	Reserved	TxlEn	RXlEn	IdlelEn	HiAlertlEn	LoAlertlEn	ErrlEn	TimerlEn
6333h	CIU_DivlEn	Reserved			SignAct lEn	ModelEn	CRCIEEn	RfOnlEn	RfOfflEn
6334h	CIU_Commlrq	Set1	TxlRq	RxlRq	Idlelrq	HiAlertlrq	LoAlertlrq	Errlrq	Timerlrq
6335h	CIU_Divlrq	Set2	Reserved		SignActlrq	ModelRq	CRCIRq	RfOnlrq	RfOfflrq
6336h	CIU_Error	WrErr	TempErr	RFErr	BufferOvfl	CollErr	CRCErr	ParityErr	ProtocollErr
6337h	CIU_Status1	CIU_IRQ_1	CRCOk	CRCReady	CIU_IRQ_0	TRunning	RFOOn	HiAlert	LoAlert
6338h	CIU_Status2	TempSensClear	Reserved	RFFreqOK	TgActivated	MFCrypto1On	ModemState[2:0]		
6339h	CIU_FIFOData	FIFOData[7:0]							
633Ah	CIU_FIFOLevel	FlushBuffer	FIFOLevel[6:0]						
633Bh	CIU_WaterLevel	Reserved			WaterLevel[5:0]				
633Ch	CIU_Control	TStopNow	TStartNow	WrNFCIP-1IDtoFIFO	Initiator	Reserved	RxLastBits[2:0]		
633Dh	CIU_BitFraming	StartSend	RxAlign[2:0]			Reserved	TxLastBits[2:0]		
633Eh	CIU_Coll	ValuesAfterColl	Reserved	CollPosNotValid	CollPos				
633Fh to FFFFh	Reserved								

8.7.2 SFR registers

Table 289. SFR registers mapping

SFR address	Register name	Bit7	Bit6	Bit5	Bit4	Bit3	Bit2	Bit1	Bit0	
80h	Reserved									
81h ^[1]	SP Stack Pointer								SP[7:0]	
82h ^[1]	DPL Data Pointer Low								DPL[7:0]	
83h ^[1]	DPH Data Pointer High								DPLH7:0]	
84h to 86h	Reserved									
87h	PCON	SMOD	Reserved					CPU_PD	Reserved	
88h	T01CON	TF1	TR1	TF0	TR0	IE1	IT1	IE0	IT0	
89h	T01MOD	GATE1	C/T1	M11	M10	GATE0	C/T0	M01	M00	
8Ah	T0L	T0L.7	T0L.6	T0L.5	T0L.4	T0L.3	T0L.2	T0L.1	T0L.0	
8Bh	T1L	T1L.7	T1L.6	T1L.5	T1L.4	T1L.3	T1L.2	T1L.1	T1L.0	
8Ch	T0H	T0H.7	T0H.6	T0H.5	T0H.4	T0H.3	T0H.2	T0H.1	T0H.0	
8Dh	T1H	T1H.7	T1H.6	T1H.5	T1H.4	T1H.3	T1H.2	T1H.1	T1H.0	
8Eh to 97h	Reserved									
98h	S0CON	SM0	SM1	SM2	REN	TB8	RB8	TI	RI	
99h	S0BUF	S0BUF[7:0]								
9Ah	RWL	RWaterlevel[7:0]								
9Bh	TWL	TWaterlevel[7:0]								
9Ch	FIFOFS	TransmitFreespace[7:0]								
9Dh	FIFOFF	ReceiveFullness[7:0]								
9Eh	SFF	FIFO_EN	Reserved	TWLL	TFF	TFE	RWLH	RFF	RFE	
9Fh	FIT	Reset	Reserved	WCOL_IRQ	TWLL_IRQ	TFF_IRQ	RWLH_IRQ	ROVR_IRQ	RFF_IRQ	
A0h	Reserved									
A1h	FITEN	TFLUSH	RFLUSH	EN_WCOL_IRQ	EN_TWLL_IRQ	EN_TFF_IRQ	EN_RWLH_IRQ	EN_ROVR_IRQ	EN_RFF_IRQ	
A2h	FDATA	FDATA[7:0]								
A3h	FSIZE	ReceiveSize[7:0]								
A4h to A7h	Reserved									
A8h	IE0	IE0_7	IE0_6	IE0_5	IE0_4	IE0_3	IE0_2	IE0_1	IE0_0	
A9h	SPIcontrol	Reserved		Enable	Reserved	CPHA	CPOL	IE1	IE0	
AAh	SPIstatus	Reserved				TR_FE	RCV_OVR	Reserved	READY	
ABh	HSU_STA	set_bit	Reserved		disable_preamb	irq_rx_over_en	irq_rx_fer_en	irq_rx_over	irq_rx_fer	
ACH	HSU_CTR	hsu_wu_en	start_frame	tx_stopbit[1:0]		rx_stopbit	tx_en	rx_en	soft_reset_n	
ADh	HSU_PRE	hsu_prescaler[7:0]								
A Eh	HSU_CNT	hsu_counter[7:0]								
AFh	Reserved									
B0h	P3	Reserved		P3[5]	P3[4]	P3[3]	P3[2]	P3[1]	P3[0]	

Table 289. SFR registers mapping ...continued

SFR address	Register name	Bit7	Bit6	Bit5	Bit4	Bit3	Bit2	Bit1	Bit0	
B1h to B7h	Reserved									
B8h	IP0	IP0_7	IP0_6	IP0_5	IP0_4	IP0_3	IP0_2	IP0_1	IP0_0	
B9h to C7h	Reserved									
C8h	T2CON	TF2	Reserved	RCLK0	TCLK0	Reserved	TR2	C/T2	CP/RL2	
C9h	T2MOD	Reserved					T2RD	DCEN		
CAh	RCAP2L	R2L.7	R2L.6	R2L.5	R2L.4	R2L.3	R2L.2	R2L.1	R2L.0	
CBh	RCAP2H	R2H.7	R2H.6	R2H.5	R2H.4	R2H.3	R2H.2	R2H.1	R2H.0	
CCh	T2L	T2L.7	T2L.6	T2L.5	T2L.4	T2L.3	T2L.2	T2L.1	T2L.0	
CDh	T2H	T2H.7	T2H.6	T2H.5	T2H.4	T2H.3	T2H.2	T2H.1	T2H.0	
CEh to CFh	Reserved									
D0h ^[1]	PSW Program Status Word	PSW[7:0]								
D1h	CIU_Command	Reserved		RcvOff	Power-down	Command				
D2h	CIU_CommIE	TxIE		RXIE	IdleIE	HiAlertIE	LoAlertIE	ErrIE	TimerIE	
D3h	CIU_DivIE	Reserved			SignActIE	ModeIE	CRCIE	RfOnIE	RfOffIE	
D4h	CIU_CommIReq	Set1	TxIRq	RxIRq	IdleIReq	HiAlertIReq	LoAlertIReq	ErrIReq	TimerIReq	
D5h	CIU_DivIReq	Set2	Reserved		SignActIReq	ModeIReq	CRCIReq	RfOnIReq	RfOffIReq	
D6h	CIU_Error	WrErr	TempErr	RFErr	BufferOvfl	CollErr	CRCErr	ParityErr	ProtocollErr	
D7h	Reserved									
D8h	I ² CCON	CR[2]	ENS1	STA	STO	SI	AA	CR[1:0]		
D9h	I ² CSTA	ST[7:0]								
DAh	I ² CDAT	I ² CDAT[7:0]								
DBh	I ² CADR	SA[6:0]							GC	
DCh to DEh	Reserved									
DFh	CIU_Status1	CIU_IRQ_1	CRCOK	CRCReady	CIU_IRQ_0	TRunning	RFO	HiAlert	LoAlert	
E0h ^[1]	ACC Accumulator	ACC[7:0]								
E1h to E7h	Reserved									
E8h	IE1	IE1_7	Reserved	IE1_5	IE1_4	IE1_3	IE1_2	Reserved	IE1_0	
E9h	CIU_Status2	TempSensClear	Reserved	RFFreqOK	TgActivated	MFCrypto1On	ModemState[2:0]			
EAh	CIU_FIFOData	FIFOData[7:0]								
EBh	CIU_FIFOLevel	FlushBuffer	FIFOLevel[6:0]							
ECh	CIU_WaterLevel	WaterLevel[5:0]								
EDh	CIU_Control	TStopNow	TStartNow	WrNFCIP-1ID to FIFO	Initiator	Reserved	RxLastBits[2:0]			
EEh	CIU_BitFraming	StartSend	RxAlign[2:0]			Reserved	TxLastBits[2:0]			
EFh	CIU_Coll	ValuesAfterColl	CollPosNotValid		CollPos					
F0h ^[1]	B register	B[7:0]								

Table 289. SFR registers mapping ...continued

SFR address	Register name	Bit7	Bit6	Bit5	Bit4	Bit3	Bit2	Bit1	Bit0
F1h to F3h	Reserved								
F4h	P7FGA						P7CFGA[2]	P7CFGA[1]	P7CFGA[0]
F5h	P7FGB						P7CFGB[2]	P7CFGB[1]	P7CFGB[0]
F6h	Reserved								
F7h	P7						P7[2]	P7[1]	P7[0]
F8h	IP1	IP1_7		IP1_5	IP1_4	IP1_3	IP1_2		
F9h	Reserved								
FAh ^[1]	XRAMP						XRAMP[4:0]		
FBh	Reserved								
FCh	P3FGA			P3CFGA[5]	P3CFGA[4]	P3CFGA[3]	P3CFGA[2]	P3CFGA[1]	P3CFGA[0]
FDh	P3FGB			P3CFGB[5]	P3CFGB[4]	P3CFGB[3]	P3CFGB[2]	P3CFGB[1]	P3CFGB[0]
FEh to FFh	Reserved								

[1] This register is not described in this document as it is a standard 80C51 register.

9. Limiting values

Table 290. Limiting values

In accordance with the Absolute Maximum Rating System (IEC 60134).

Symbol	Parameter	Conditions	Min	Max	Unit
PV _{DD}	Supply Voltage		-0.5	4	V
V _{BAT}	Power Supply Voltage		-0.5	6.0	V
P _{tot}	Total power dissipation			500	mW
I _{TVDD}	Maximum current in TVDD		[1]	150	mA
I _{SVDD}	Maximum current in SVDD switch			30	mA
V _{ESD}	Electrostatic discharge voltage				
V _{ESDH}	ESD Susceptibility (Human Body model)	1500 Ω, 100pF; EIA/JESD22-A114-D		± 2.0	kV
V _{ESDM}	ESD Susceptibility (Machine model)	0.75 mH, 200 pF; EIA/JESD22-A115-A		200	V
V _{ESDC}	ESD Susceptibility (Charge Device model)	Field induced model; EIA/JESC22-C101-C		± 1.0	kV
T _{stg}	Storage temperature		-55	150	°C
T _j	Junction temperature		-40	125	°C

[1] The antenna should be tuned not to exceed this current limit (the detuning effect when coupling with another device must be taken into account)

10. Recommended operating conditions

Table 291. Operating conditions

Symbol	Parameter	Conditions	Min	Typ	Max	Unit
T _{amb}	Ambient Temperature		-30	+25	+85	°C
V _{BAT}	Power Supply Voltage	V _{SS} = 0 V	[1] [2] 2.7		5.5	V
PV _{DD}	Supply Voltage for host interface	V _{SS} = 0 V	[3] 1.6	1.8 to 3.3	3.6	V

[1] V_{SS} represents DV_{SS}, TV_{SS1}, TV_{SS2}, AV_{SS}.

[2] Supply voltage of V_{BAT} below 3.3 V reduces the performance (e.g. the achievable operating distance).

[3] It is possible to supply PV_{DD}=0V and to use the PN532 with reduced functionality (see [Section 8.4 "Power management" on page 83](#))

11. Thermal characteristics

Table 292. Thermal characteristics

Symbol	Parameter	Conditions	Min	Typ	Max	Unit
R _{thj-a}	thermal resistance from junction to ambient	in free air with exposed pad soldered on a 4 layer Jedec PCB-0.5		37	41.1	K/W

12. Characteristics

Unless otherwise specified, the limits are given for the full operating conditions. The typical value is given for 25°C, VBAT = 3.4 V and PVDD = 3 V.

Timings are only given from characterization results.

12.1 Power management characteristics

Table 293. Power management characteristics

Symbol	Parameter	Conditions	Min	Typ	Max	Unit
VBAT	Battery power supply range	V _{SS} = 0 V	2.7		5.5	V
V _{DVDD}	LDO output	VBAT > 3.4 V I _{DVDD} = 150 mA	2.7	3	3.4	V
LDO _{OFF}	LDO offset	VBAT = 3.4 V I _{DVDD} =150 mA Offset enabled	300	400	700	mV
V _{th1}	Reset threshold on DV _{DD} falling		2.04	2.32	2.6	V
V _{hys1}	V _{th1} hysteresis		40		90	mV
C _{dec}	DVDD decoupling capacitor	Low ESR, like X7R or X5R ceramic capacitor	[1] 10			μF
PSR	Power supply rejection on DV _{DD}	LDO offset enabled. F < 10 kHz. C _{dec} = 10 μF		-46		dB
F _{cPSR}	PSR -3dB cut-off frequency	Standard LDO mode. C _{dec} = 10 μF		10		kHz
SV _{DD}	SV _{DD} output voltage	VBAT > 3.4 V I _{SVDD} = 30 mA	2.7		3.3	VV

[1] Decreasing the decoupling capacitance can decrease the power supply bursts rejection.

[2] The capacitance should be placed closed to the pins, and can be splitted (see [Figure 51 on page 212](#))

12.2 Overcurrent detection

The following values are guaranteed by design. Only functional testing is done in production for case Sel_overcurrent1 = Sel_overcurrent0 = 1.

Table 294. Overcurrent detection characteristics

Symbol	Parameter	Conditions	Min	Typ	Max	Unit
I _{Overcurrent}	I _{DVDD} threshold for overcurrent detection	Sel_overcurrent1=0 Sel_overcurrent0=0		300		mA
		Sel_overcurrent1=0 Sel_overcurrent0=1		210		mA
		Sel_overcurrent1=1 Sel_overcurrent0=0		180		mA
		Sel_overcurrent1=1 Sel_overcurrent0=1		150		mA

12.3 Current consumption characteristics

Table 295. Current consumption characteristics

Symbol	Parameter	Conditions	Min	Typ	Max	Unit
I _{HPD}	Hard-Power-Down current	V _{BAT} = 3.4 V P _{VDD} = 3 V	[5]		2	μA
I _{SPD}	Soft-Power-Down current	V _{BAT} = 3.6 V P _{VDD} = 3 V RF level detector ON	[5][7]	25	45	μA
I _{SPD}	Soft-Power-Down current	V _{BAT} = 3.6 V P _{VDD} = 3 V RF level detector OFF	[5][7]	18	40	μA
I _{AVDD}	Analog supply current	V _{BAT} = 3.4 V P _{VDD} = 3 V		3	10	mA
I _{PVDD}	Pad supply current		[2]	0.5	45	mA
I _{SVDD}	Secure IC supply current	Switch closed	[3]	3	30	mA
I _{TVDD}	Transmitter supply current	Continuous wave, V _{BAT} = 3.4 V	[1]	60	100	mA
I _{VBAT}	Total supply current	Continuous wave, V _{BAT} = 3.4 V	[4][6]		150	mA

- [1] Typical value using a complementary driver configuration and an antenna matched to 40 Ω between TX1 and TX2 at 13.56 MHz.
- [2] I_{PVDD} depends on the overall load at the pins. The maximum is given assuming 4mA output current for the I/O or output pads.
- [3] I_{SVDD} depends on the overall load on S_{VDD} pad.
- [4] During operation with recommended antenna tuning circuitry the overall current is below 100 mA.
- [5] I_{SPD} and I_{HPD} are the total currents across all supplies with the PN532xA3HN/C104 and PN532xA3HN/C105.
- [6] The antenna should be tuned not to exceed this current limit (the detuning effect when coupling with another device must be taken into account)
- [7] These values are valid when applied the Soft-Power-Down sequence described in [Section 8.5.4 on page 91](#), and with TESTEN pin connected to DVSS.

12.4 Antenna presence self test thresholds

The following values are guaranteed by design. Testing is done in production for cases $\text{andet_ithl}[1:0]=10\text{b}$ and for $\text{andet_ithh}[2:0]=011\text{b}$.

The operating range is:

- VBAT voltage above 5V
- Ambient temperature between 0 and 40°C

Table 296. Antenna presence detection lower levels characteristics

Symbol	Parameter	Conditions	Min	Typ	Max	Unit
I_{AndetH}	I_{DVDD} lower current threshold for antenna presence detection	$\text{andet_ithl}[1:0] = 10\text{b}$	20		37	mA
		$\text{andet_ithl}[1:0] = 11\text{b}$	27		49	mA

Table 297. Antenna Presence Detection Upper Levels characteristics

Symbol	Parameter	Conditions	Min	Typ	Max	Unit
I_{AndetH}	I_{DVDD} upper current threshold for antenna presence detection	$\text{andet_ithh}[2:0] = 000\text{b}$	31		56	mA
		$\text{andet_ithh}[2:0] = 001\text{b}$	42		74	mA
		$\text{andet_ithh}[2:0] = 010\text{b}$	52		92	mA
		$\text{andet_ithh}[2:0] = 011\text{b}$	63		110	mA
		$\text{andet_ithh}[2:0] = 100\text{b}$	73		128	mA
		$\text{andet_ithh}[2:0] = 101\text{b}$	84		146	mA
		$\text{andet_ithh}[2:0] = 110\text{b}$	94		164	mA
		$\text{andet_ithh}[2:0] = 111\text{b}$	105		182	mA

12.5 Typical 27.12 MHz Crystal requirements

Table 298. Crystal requirements

Symbol	Parameter	Conditions	Min	Typ	Max	Unit
f_{XTAL}	XTAL frequency		27.107	27.12	27.133	MHz
ESR	Equivalent series resistance			50		Ω
C_{LOAD}	Load capacitance			10		pF
P_{XTAL}	Drive level		100			μW

12.6 Pin characteristics for 27.12 MHz XTAL Oscillator (OSCIN, OSCOUT)

Table 299. Pin characteristics for 27.12 MHz XTAL Oscillator (OSCIN, OSCOUT)

Symbol	Parameter	Conditions	Min	Typ	Max	Unit
$C_{inOSCIN}$	OSCIN Input Capacitance	$AV_{DD} = 2.8\text{ V}$, $V_{DC} = 0.65\text{ V}$, $V_{AC} = 0.9\text{ V}_{pp}$		2		pF
$V_{OHOSCOUT}$	High level output voltage			1.1		V
$V_{OLOSCOUT}$	Low level output voltage			0.2		V
$C_{inOSCOUT}$	OSCOUT Input Capacitance			2		pF
f_{OSCIN}	Clock Frequency	with appropriate quartz and capacitances values	[1]	27.12		MHz
D_{FEC}	Duty Cycle of Clock Frequency	with appropriate quartz and capacitances values	[1]	45	50	55 %
t_{jitter}	Jitter of Clock Edges	with appropriate quartz and capacitances values	[1]		10	ps RMS

[1] See the [Figure 51 on page 212](#) for example of appropriate connected components. The layout should ensure minimum distance between the pins and the components

12.7 RSTPD_N input pin characteristics

Table 300. RSTPD_N input pin characteristics

Symbol	Parameter	Conditions	Min	Typ	Max	Unit
V_{IH}	High level input voltage	$PV_{DD} > 1.6\text{ V}$	$0.9 \times PV_{DD}$		3.6	V
V_{IH}	High level input voltage	$PV_{DD} < 0.4\text{ V}$ (see Section 8.4 on page 83)	$0.65 \times V_{BAT}$		3.6	V
V_{IL}	Low level input voltage	$PV_{DD} > 1.6\text{ V}$	0		0.4	V
V_{IL}	Low level input voltage	$PV_{DD} < 0.4\text{ V}$ (see Section 8.4 on page 83)	0		0.4	V
I_{IH}	High level input current	$V_I = PV_{DD}$	-1		1	μA
I_{IL}	Low level input current	$V_I = 0\text{ V}$	-1		1	μA
C_{in}	Input capacitance				2.5	pF

12.8 Input pin characteristics for I0 and I1

Table 301. Input pin characteristics for I0, I1 and TESTEN

Symbol	Parameter	Conditions	Min	Typ	Max	Unit
V _{IH}	High level input voltage		[1] $0.7 \times DV_{DD}$		DV _{DD}	V
V _{IL}	Low level input voltage		[2] 0		$0.3 \times DV_{DD}$	V
I _{IH}	High level input current I0 and I1	V _I = DV _{DD}	-1		1	μA
I _{IL}	Low level input current	V _I = 0 V	-1		1	μA
C _{in}	Input capacitance			2.5		pF

[1] To minimize power consumption when in Soft-Power-Down mode, the limit is DV_{DD} - 0.4 V.

[2] To minimize power consumption when in Soft-Power-Down mode, the limit is 0.4 V.

12.9 RSTOUT_N output pin characteristics

Table 302. RSTOUT_N output pin characteristics

Symbol	Parameter	Conditions	Min	Typ	Max	Unit
V _{OH}	High level output voltage	PV _{DD} = 3 V, I _{OH} = -4 mA			PV _{DD}	V
		PV _{DD} = 1.8 V, I _{OH} = -2 mA	[2] $0.7 \times PV_{DD}$		PV _{DD}	V
V _{OL}	Low level output voltage	PV _{DD} = 3 V, I _{OL} = 4 mA	0		$0.3 \times PV_{DD}$	V
		PV _{DD} = 1.8 V, I _{OL} = 2 mA	[2] 0		$0.3 \times PV_{DD}$	V
C _{out}	Load capacitance			30		pF
t _{rise,fall}	Rise and fall times	PV _{DD} = 3 V, V _{OH} = $0.8 \times PV_{DD}$, V _{OL} = $0.2 \times PV_{DD}$, C _{out} = 30 pF	[1]	13.5		ns
		PV _{DD} = 1.8 V, V _{OH} = $0.7 \times PV_{DD}$, V _{OL} = $0.3 \times PV_{DD}$, C _{out} = 30 pF		10.8		ns

[1] I_{OH} and I_{OL} give the output drive capability from which the rise and fall times may be calculated as a function of the load capacitance.

[2] Data at PV_{DD}= 1.8V are only given from characterization results.

12.10 Input/output characteristics for pin P70_IRQ

Table 303. Input/output pin characteristics for pin P70_IRQ

Symbol	Parameter	Conditions	Min	Typ	Max	Unit
V _{IH}	High level input voltage		[1] 0.7 × PV _{DD}		PV _{DD}	V
V _{IL}	Low level input voltage		[2] 0		0.3 × PV _{DD}	V
V _{OH}	Push-pull mode high level output voltage	PV _{DD} = 3 V, I _{OH} = -4 mA	0.7 × PV _{DD}		PV _{DD}	V
		PV _{DD} = 1.8 V, I _{OH} = -2 mA	[3] 0.7 × PV _{DD}		PV _{DD}	V
V _{OL}	Push-pull mode low level output voltage	PV _{DD} = 3 V, I _{OL} = 4 mA	0		0.3 × PV _{DD}	V
		PV _{DD} = 1.8 V, I _{OL} = 2 mA	[3] 0		0.3 × PV _{DD}	V
I _{IH}	Input mode high level input current	V _I = DV _{DD}	-1		1	μA
I _{IL}	Input mode low level input current	V _I = 0 V	-1		1	μA
I _{Leak}	Input leakage current	RSTPD_N = 0.4 V	-1		1	μA
C _{in}	Input capacitance			2.5		pF
C _{out}	Load capacitance				30	pF
t _{rise,fall}	Rise and fall times	PV _{DD} = 3 V, V _{OH} = 0.8 × PV _{DD} , V _{OL} = 0.2 × PV _{DD} , C _{out} = 30 pF			13.5	ns
		PV _{DD} = 1.8 V, V _{OH} = 0.7 × PV _{DD} , V _{OL} = 0.3 × PV _{DD} , C _{out} = 30 pF			10.8	ns

[1] To minimize power consumption when in Soft-Power-Down mode, the limit is PV_{DD} - 0.4 V.

[2] To minimize power consumption when in Soft-Power-Down mode, the limit is 0.4 V

[3] Data at PVDD= 1.8V are only given from characterization results.

12.11 Input/output pin characteristics for P30 / UART_RX, P31 / UART_TX, P32_INT0, P33_INT1

Table 304. Input/output pin characteristics for P30 / UART_RX, P31 / UART_TX, P32_INT0, P33_INT1

Symbol	Parameter	Conditions	Min	Typ	Max	Unit
V _{IH}	High level input voltage		[1] $0.7 \times PV_{DD}$		PV _{DD}	V
V _{IL}	Low level input voltage		[2] 0		$0.3 \times PV_{DD}$	V
V _{OH}	Push-pull mode high level output voltage	PV _{DD} = 3 V, I _{OH} = -4 mA			PV _{DD}	V
		PV _{DD} = 1.8 V, I _{OH} = -2 mA	[3] $PV_{DD} - 0.4$		PV _{DD}	V
V _{OL}	Push-pull mode low level output voltage	PV _{DD} = 3 V, I _{OL} = 4 mA	0		0.4	V
		PV _{DD} = 1.8 V, I _{OL} = 2 mA	[3] 0		0.4	V
I _{IH}	Input mode high level input current	V _I = PV _{DD}	-1		1	μA
I _{IL}	Input mode low level input current	V _I = 0 V	-1		1	μA
I _{Leak}	Input leakage current	RSTPD_N = 0.4 V	-1		1	μA
C _{in}	Input capacitance			2.5		pF
C _{out}	Load capacitance				30	pF
t _{rise,fall}	Rise and fall times	PV _{DD} = 3 V, V _{OH} = $0.8 \times PV_{DD}$, V _{OL} = $0.2 \times PV_{DD}$, C _{out} = 30 pF			13.5	ns
		PV _{DD} = 1.8 V, V _{OH} = $0.7 \times PV_{DD}$, V _{OL} = $0.3 \times PV_{DD}$, C _{out} = 30 pF			10.8	ns

[1] To minimize power consumption when in Soft-Power-Down mode, the limit is PV_{DD} - 0.4 V.

[2] To minimize power consumption when in Soft-Power-Down mode, the limit is 0.4 V

[3] Data at PVDD= 1.8V are only given from characterization results.

12.12 Input/output pin characteristics for P34 / SIC_CLK

Table 305. Input/output pin characteristics for P34 / SIC_CLK

Symbol	Parameter	Conditions	Min	Typ	Max	Unit
V _{IH}	High level input voltage		[1] 0.7 × SV _{DD}		SV _{DD}	V
V _{IL}	Low level input voltage		[2] 0		0.3 × SV _{DD}	V
V _{OH}	Push-pull mode high level output voltage	V _{BAT} = 3.4 V, I _{OH} = -4 mA	SV _{DD} - 0.4		SV _{DD}	V
V _{OL}	Push-pull mode low level output voltage	V _{BAT} = 3.4 V, I _{OL} = 4 mA	0		0.4	V
I _{IH}	Input mode high level input current	V _I = SV _{DD}	-1		1	μA
I _{IL}	Input mode low level input current	V _I = 0 V	-1		1	μA
I _{Leak}	Input leakage current	RSTPD_N = 0.4 V	-1		1	μA
C _{in}	Input Capacitance			2.5		pF
C _{out}	Load Capacitance				30	pF
t _{rise,fall}	Rise and fall times	V _{BAT} = 3.4 V, V _{OH} = 0.8 × SV _{DD} , V _{OL} = 0.2 × SV _{DD} , C _{out} = 30 pF		13.5		ns

[1] To minimize power consumption when in Soft-Power-Down mode, the limit is SV_{DD} - 0.4 V.

[2] To minimize power consumption when in Soft-Power-Down mode, the limit is 0.4 V.

12.13 Input/output pin characteristics for P35

Table 306. Input/output pin characteristics for P35

Symbol	Parameter	Conditions	Min	Typ	Max	Unit
V _{IH}	High level Input voltage		[1] 0.7 × DV _{DD}		DV _{DD}	V
V _{IL}	Low level Input voltage		[2] 0		0.3 × DV _{DD}	V
V _{OH}	High level output voltage	V _{BAT} = 3.4 V, I _{OH} = -4 mA	DV _{DD} - 0.4		DV _{DD}	V
V _{OL}	Low level output voltage	V _{BAT} = 3.4 V, I _{OL} = 4 mA	0		0.4	V
I _{IH}	High level input current	V _I = DV _{DD}	-1		1	μA
I _{IL}	Low level input current	V _I = 0 V	-1		1	μA
I _{Leak}	Input leakage current	RSTPD_N = 0.4 V	-1		1	μA
C _{in}	Input Capacitance			2.5		pF
C _{out}	Load Capacitance				30	pF
t _{rise,fall}	Rise and fall times	V _{BAT} = 3.4 V, V _{OH} = DV _{DD} - 0.4, V _{OL} = 0.4, C _{out} = 30 pF		16.5		ns

[1] To minimize power consumption when in Soft-Power-Down mode, the limit is DV_{DD} - 0.4 V.

[2] To minimize power consumption when in Soft-Power-Down mode, the limit is 0.4 V.

12.14 Input pin characteristics for NSS / P50_SCL / HSU_RX

Table 307. Input pin characteristics for NSS / HSU_RX for HSU / SPI interfaces

Symbol	Parameter	Conditions	Min	Typ	Max	Unit
V _{IH}	High level Input voltage	PV _{DD} > 1.6V	[1] [3] 0.7 × PV _{DD}		PV _{DD}	V
V _{IL}	Low level Input voltage	PV _{DD} > 1.6V	[2] 0		0.3 × PV _{DD}	V
I _{IH}	High level input current	V _I = DV _{DD}	-1		1	μA
I _{IL}	Low level input current	V _I = 0 V	-1		1	μA
I _{Leak}	Input leakage current	RSTPD_N = 0.4 V	-1		1	μA
C _{in}	Input Capacitance			2.5		pF
T _{SP}	Width of suppressed spikes			20		ns

- [1] To minimize power consumption when in Soft-Power-Down mode, the limit is PV_{DD} - 0.4 V.
- [2] To minimize power consumption when in Soft-Power-Down mode, the limit is 0.4 V.
- [3] When PVDD is not present, it is not possible to define a high level on NSS. When using SPI host interface, a wake-up condition can not be avoided if PVDD is absent.

Table 308. Input/open drain output pin characteristics for P50_SCL for I²C interface

Symbol	Parameter	Conditions	Min	Typ	Max	Unit
V _{IH}	High level Input voltage		[1] 0.7 × PV _{DD}		PV _{DD}	V
V _{IL}	Low level Input voltage		[2] 0		0.3 × PV _{DD}	V
V _{OL}	Low level output voltage	PV _{DD} = 3 V, I _{OL} = 4 mA	0		0.3	V
		PV _{DD} = 1.8 V, I _{OL} = 2 mA	[3] 0		0.3	V
I _{IH}	High level input current	V _I = DV _{DD}	-1		1	μA
I _{IL}	Low level input current	V _I = 0 V	-1		1	μA
I _{Leak}	Input leakage current	RSTPD_N = 0.4 V	-1		1	μA
C _{in}	Input Capacitance			2.5		pF
C _{out}	Load Capacitance				30	pF
T _{SP}	Width of suppressed spikes	Out of SPD mode		20		ns
T _{SP}	Width of suppressed spikes	In SPD mode		120		ns

- [1] To minimize power consumption when in Soft-Power-Down mode, the limit is PV_{DD} - 0.4 V.
- [2] To minimize power consumption when in Soft-Power-Down mode, the limit is 0.4 V.
- [3] Data at PVDD= 1.8V are only given from characterization results.

12.15 Input/output pin characteristics for MOSI / SDA / HSU_TX

Table 309. Input/output pin characteristics for MOSI / HSU_TX for HSU and SPI Interfaces

Symbol	Parameter	Conditions	Min	Typ	Max	Unit
V _{IH}	High level Input voltage		[1] 0.7 × PV _D D		PV _{DD}	V
V _{IL}	Low level Input voltage		[2] 0		0.3 × PV _D D	V
V _{OH}	HSU_TX high level output voltage	PV _{DD} = 3 V, I _{OH} = -4 mA			PV _{DD} - 0.4	V
		PV _{DD} = 1.8 V, I _{OH} = -2 mA	[3] PV _{DD} - 0.4		PV _{DD}	V
V _{OL}	HSU_TX low level output voltage	PV _{DD} = 3 V, I _{OL} = 3 mA	0		0.3	V
I _{IH}	MOSI high level input current	V _I = DV _{DD}	-1		1	μA
I _{IL}	MOSI low level input current	V _I = 0 V	-1		1	μA
I _{Leak}	Input leakage current	RSTPD_N = 0.4 V	-1		1	μA
C _{in}	Input Capacitance			2.5		pF
C _{out}	Load Capacitance				30	pF
T _{SP}	Width of suppressed spikes			20		ns

[1] To minimize power consumption when in Soft-Power-Down mode, the limit is PV_{DD} - 0.4 V.

[2] To minimize power consumption when in Soft-Power-Down mode, the limit is 0.4 V.

[3] Data at PVDD= 1.8V are only given from characterization results.

Table 310. Input/open drain output pin characteristics for SDA for I²C interface

Symbol	Parameter	Conditions	Min	Typ	Max	Unit
V _{IH}	High level Input voltage		[1] 0.7 × PV _{DD}		PV _{DD}	V
V _{IL}	Low level Input voltage		[2] 0		0.3 × PV _{DD}	V
V _{OL}	Low level output voltage	PV _{DD} = 3 V, I _{OL} = -4 mA	0		0.3	V
		PV _{DD} = 1.8 V, I _{OL} = -2 mA	[3] 0		0.3	V
I _{IH}	High level input current	V _I = DV _{DD}	-1		1	μA
I _{IL}	Low level input current	V _I = 0 V	-1		1	μA
I _{Leak}	Input leakage current	RSTPD_N = 0.4 V	-1		1	μA
C _{in}	Input Capacitance			2.5		pF
C _{out}	Load Capacitance				30	pF
T _{SP}	Width of suppressed spikes	Out of SPD mode		20		ns
		In SPD mode		150		ns

[1] To minimize power consumption when in Soft-Power-Down mode, the limit is PV_{DD} - 0.4 V.

[2] To minimize power consumption when in Soft-Power-Down mode, the limit is 0.4 V.

[3] Data at PVDD= 1.8V are only given from characterization results.

12.16 Input/output pin characteristics for MISO / P71 and SCK / P72

Table 311. Input/output pin characteristics for MISO / P71 and SCK / P72

Symbol	Parameter	Conditions	Min	Typ	Max	Unit
V _{IH}	High level Input voltage		[1] $0.7 \times PV_{DD}$		PV _{DD}	V
V _{IL}	Low level Input voltage		[2] 0		$0.3 \times PV_{DD}$	V
V _{OH}	Push_pull / MISO mode high level output voltage	PV _{DD} = 3 V, I _{OH} = -4 mA			PV _{DD}	V
		PV _{DD} = 1.8 V, I _{OH} = -2 mA	[3] $PV_{DD} - 0.4$		PV _{DD}	V
V _{OL}	Push_pull / MISO mode low level output voltage	PV _{DD} = 3 V, I _{OL} = -4 mA			0.4	V
		PV _{DD} = 1.8 V, I _{OL} = -2 mA	[3] 0		0.4	V
I _{IH}	Input mode high level input current	V _I = DV _{DD}	-1		1	μA
I _{IL}	Input mode low level input current	V _I = 0 V	-1		1	μA
I _{Leak}	Input leakage current	RSTPD_N = 0.4 V	-1		1	μA
C _{in}	Input Capacitance			2.5		pF
C _{out}	Load Capacitance				30	pF
T _{SP}	Width of suppressed spikes	Only valid for SCK		15		ns

[1] To minimize power consumption when in Soft-Power-Down mode, the limit is PV_{DD} - 0.4 V.

[2] To minimize power consumption when in Soft-Power-Down mode, the limit is 0.4 V.

[3] Data at PVDD= 1.8 V are only given from characterization results.

12.17 Input pin characteristics for SIGIN

Table 312. Input/output pin characteristics for SIGIN

Symbol	Parameter	Conditions	Min	Typ	Max	Unit
V _{IH}	High level Input voltage		[1] $0.7 \times SV_{DD}$		SV _{DD}	V
V _{IL}	Low level Input voltage		[2] 0		$0.3 \times SV_{DD}$	V
I _{IH}	High level input current	V _I = SV _{DD}	-1		1	μA
I _{IL}	Low level input current	V _I = 0 V	-1		1	μA
I _{Leak}	Input leakage current	RSTPD_N = 0.4 V	-1		1	μA
C _{in}	Input Capacitance			2.5		pF

[1] To minimize power consumption when in Soft-Power-Down mode, the limit is SV_{DD} - 0.4 V.

[2] To minimize power consumption when in Soft-Power-Down mode, the limit is 0.4 V.

12.18 Output pin characteristics for SIGOUT

Table 313. Output pin characteristics for SIGOUT

Symbol	Parameter	Conditions	Min	Typ	Max	Unit
V_{OH}	High level output voltage	$DV_{DD} - 0.1 < SV_{DD} < DV_{DD}$ $I_{OH} = -4 \text{ mA}$	$SV_{DD} - 0.4$		SV_{DD}	V
V_{OL}	Low level output voltage	$DV_{DD} - 0.1 < SV_{DD} < DV_{DD}$ $I_{OL} = +4 \text{ mA}$	0		0.4	V
I_{Leak}	Input leakage current	$RSTPD_N = 0.4 \text{ V}$	-1		1	μA
C_{in}	Input Capacitance			2.5		pF
C_{out}	Load Capacitance				30	pF
$t_{rise,fall}$	Rise and fall times	$V_{BAT} = 3.4 \text{ V}$, $V_{OH} = 0.8 \times SV_{DD}$, $V_{OL} = 0.2 \times SV_{DD}$, $C_{out} = 30 \text{ pF}$		9		ns

12.19 Output pin characteristics for LOADMOD

Table 314. Output pin characteristics for LOADMOD

Symbol	Parameter	Conditions	Min	Typ	Max	Unit
V_{OH}	High level output voltage	$V_{BAT} = 3.4 \text{ V}$, $I_{OH} = -4 \text{ mA}$	$DV_{DD} - 0.4$		DV_{DD}	V
V_{OL}	Low level output voltage	$V_{BAT} = 3.4 \text{ V}$, $I_{OL} = 4 \text{ mA}$	0		0.4	V
C_{out}	Load Capacitance				10	pF
$t_{rise,fall}$	Rise and fall times	$V_{BAT} = 3.4 \text{ V}$, $V_{OH} = 0.8 \times DV_{DD}$, $V_{OL} = 0.2 \times DV_{DD}$, $C_{out} = 10 \text{ pF}$		4.5		ns

12.20 Input pin characteristics for RX

Table 315. Input pin characteristics for RX

Symbol	Parameter	Conditions	Min	Typ	Max	Unit
V_{INRX}	Dynamic Input voltage Range	VBAT = 3.4 V	-1		$AV_{DD} + 1$	V
C_{inrx}	RX Input Capacitance			10		pF
R_{inrx}	RX Input Series resistance	VBAT = 3.4 V, Receiver active, VRX = 1 Vpp, 1.5 V DC offset		350		Ω
$V_{RX,MinIV,Mill}$	Minimum Dynamic Input voltage, Miller coded	VBAT = 3.4 V, 106 kbit/s		150	500	mVpp
$V_{RX,MinIV,Man}$	Minimum Dynamic Input voltage, Manchester Coded	VBAT = 3.4 V, 212 and 424 kbit/s		100	200	mVpp
$V_{RX,MaxIV,Mill}$	Maximum Dynamic Input voltage, Miller coded	VBAT = 3.4 V, 106 kbit/s	$AV_{DD} + 1$			Vpp
$V_{RX,MaxIV,Man}$	Maximum Dynamic Input voltage, Manchester Coded	VBAT = 3.4 V, 212 and 424 kbit/s	$AV_{DD} + 1$			Vpp
$V_{mRX,Mill}$	Minimum Modulation index, Miller coded	VBAT = 3.4 V, 106 kbit/s VRX = 1.5 Vpp, SensMiller = 3		33		%
$V_{RXMod,Man}$	Minimum modulation voltage	VBAT = 3.4 V, RxGain = 6 and 7	[1]		6	mV
$V_{RXMod,Man}$	Minimum modulation voltage	VBAT = 3.4 V, RxGain = 4 and 5	[1]		18	mV
$V_{RXMod,Man}$	Minimum modulation voltage	VBAT = 3.4 V, RxGain = 0 to 3	[1]		120	mV

[1] The minimum modulation voltage is valid for all modulation schemes except Miller coded signals.

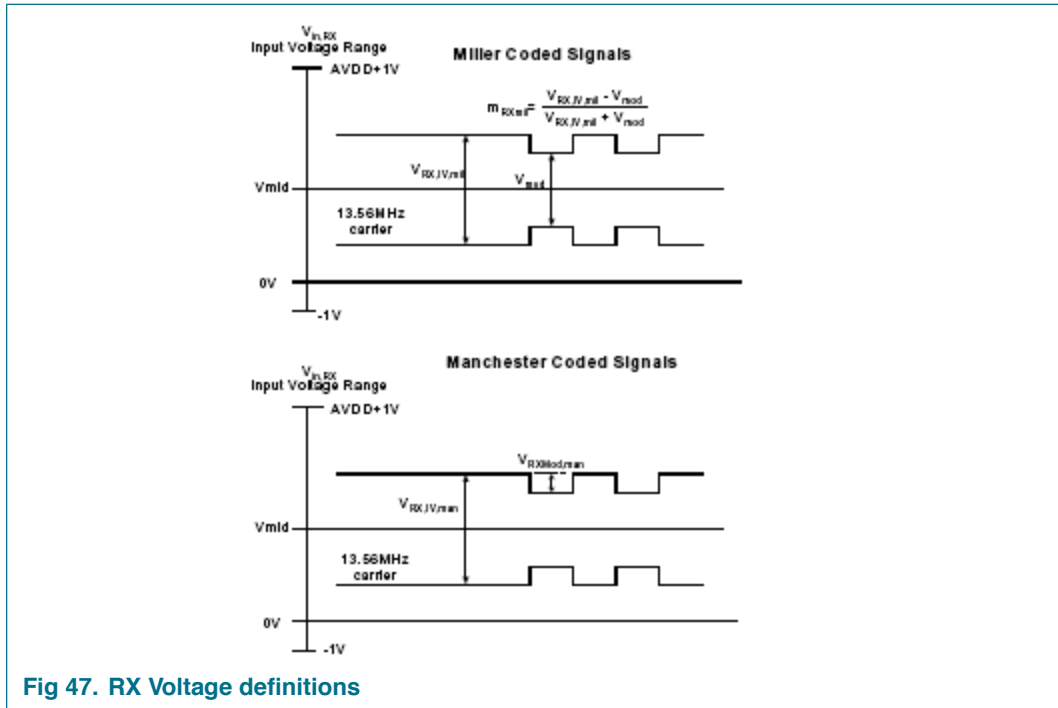

Fig 47. RX Voltage definitions

12.21 Output pin characteristics for AUX1/AUX2

Table 316. Output pin characteristics for AUX1/AUX2

Symbol	Parameter	Conditions	Min	Typ	Max	Unit
V _{OH}	High level output voltage	V _{BAT} = 3.4 V, I _{OH} = -4 mA	DV _{DD} - 0.4		DV _{DD}	V
V _{OL}	Low level output voltage	V _{BAT} = 3.4 V, I _{OL} = 4 mA	DV _{SS}		DV _{SS} +0.4	V
I _{Leak}	Input leakage current	RSTPD_N = 0 V	-1		1	μA
C _{in}	Input Capacitance			2.5		pF
C _{out}	Load Capacitance				15	pF

12.22 Output pin characteristics for TX1/TX2

Table 317. Output pin characteristics for TX1/TX2

Symbol	Parameter	Conditions	Min	Typ	Max	Unit
V _{OH} , C32, 3 V	High level output voltage	V _{BAT} = 3.4 V, I _{TX1/2} = 32 mA, CWGsP[5:0] = 3Fh	TV _{DD} - 150			mV
V _{OH} , C80, 3 V	High level output voltage	V _{BAT} = 3.4 V, I _{TX1/2} = 80 mA, CWGsP[5:0] = 3Fh	TV _{DD} - 400			mV
V _{OL} , C32, 3 V	Low level output voltage	V _{BAT} = 3.4 V, I _{TX1/2} = 32 mA, CWGsN[3:0] = Fh			150	mV
V _{OL} , C80, 3 V	Low level output voltage	V _{BAT} = 3.4 V, I _{TX1/2} = 80 mA, CWGsN[3:0] = Fh			400	mV

12.23 Timing for Reset and Hard-Power-Down

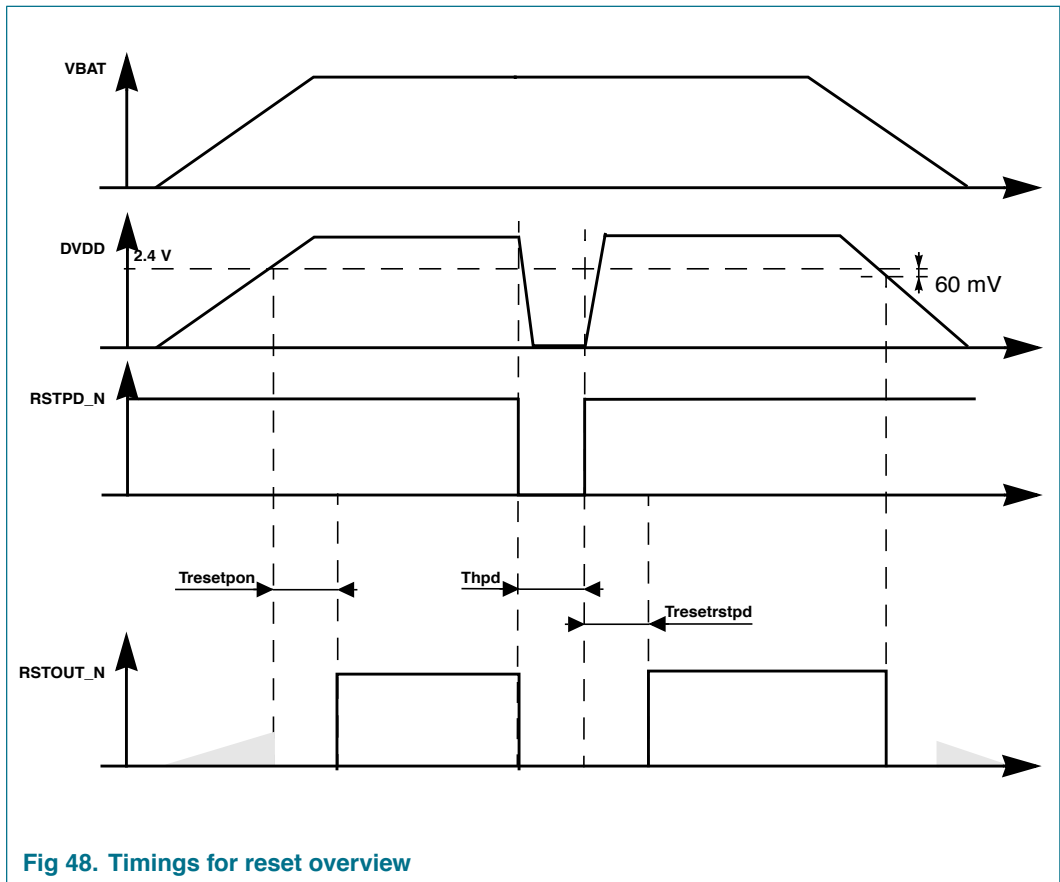

Fig 48. Timings for reset overview

Table 318. Reset duration time

Symbol	Parameter	Conditions	Min	Typ	Max	Unit
$T_{resetpon}$	Reset time at power on		[1] 0.1	0.4	2	ms
T_{HPD}	Hard Power-Down time	User dependent	20			ns
$T_{resetRSTPD_N}$	Reset time when RSTPD_N is released		[1] 0.1	0.4	2	ms

[1] 27.12 MHz quartz starts in less than 800 μ s. For example, quartz like TAS-3225A, TAS-7 or KSS2F with appropriate layout.

12.24 Timing for the SPI compatible interface

Table 319. SPI timing specification

Symbol	Parameter	Conditions	Min	Typ	Max	Unit
t_{SCKL}	SCK low pulse width		50			ns
t_{SCKH}	SCK high pulse width		50			ns
t_{SHDX}	SCK high to data changes		25			ns
t_{DXSH}	data changes to SCK high		25			ns
t_{SLDX}	SCK low to data changes				25	ns
t_{SLNH}	SCK low to NSS high		0			ns

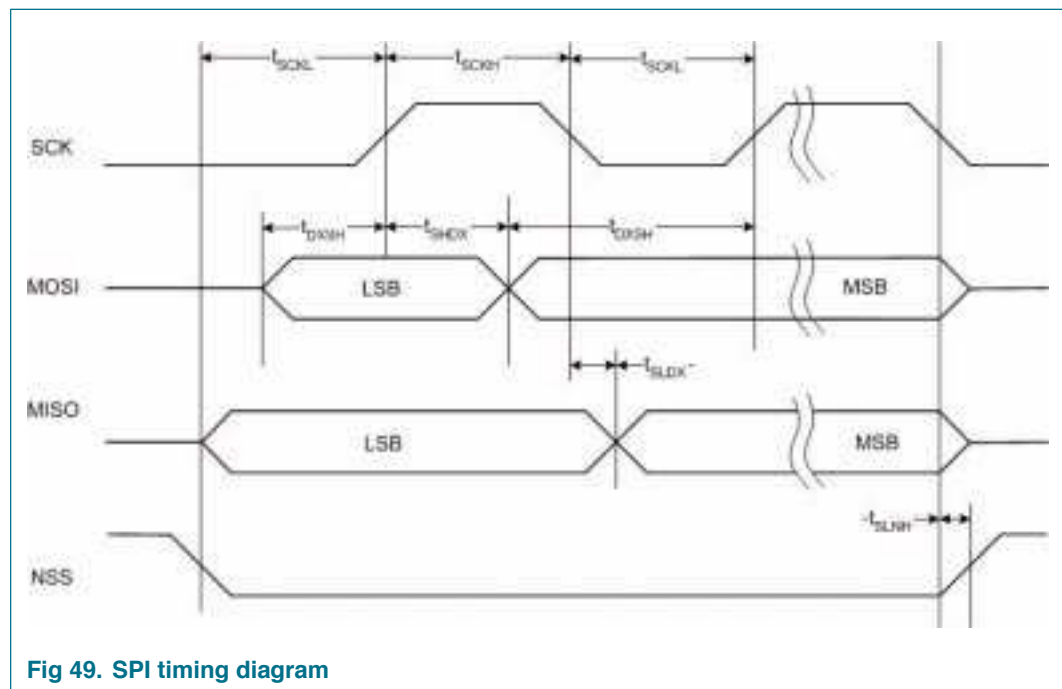

Fig 49. SPI timing diagram

12.25 Timing for the I²C interface

Table 320. I²C timing specification

Symbol	Parameter	Conditions	Min	Typ	Max	Unit
f _{SCL}	SCL clock frequency		0		400	kHz
t _{HD; STA}	Hold time (repeated) START condition.	After this period, the first clock pulse is generated	600			ns
t _{SU; STA}	Set-up time for a repeated START condition		600			ns
t _{SU; STO}	Set-up time for STOP condition		600			ns
t _{LOW}	LOW period of the P50_SCL clock		1300			ns
t _{HIGH}	HIGH period of the P50_SCL clock		600			ns
t _{HD; DAT}	Data hold time		0		900	ns
t _{SU; DAT}	Data set-up time		100			ns
t _r	Rise time P50_SCL and SDA		[1] 20		1000	ns
t _f	Fall time P50_SCL and SDA		[1] 20		300	ns
t _{BUF}	Bus free time between a STOP and START condition		1.3			ms
t _{StrWuSpd}	Stretching time on P50_SCL when woken-up on its own address		[2]		1	ms
t _{HDSDA}	Internal hold time for SDA		330		590	ns
t _{HDSDA}	Internal hold time for SDA in SPD mode		[3]		270	ns

- [1] The PN532 has a slope control according to the I²C specification for the Fast mode. The slope control is always present and not dependant of the I²C speed.
- [2] 27.12 MHz quartz starts in less than 800 μs. For example, quartz like TAS-3225A, TAS-7 or KSS2F with appropriate layout.
- [3] The PN532 has an internal hold time of around 270ns for the SDA signal to bridge the undefined region of the falling edge of P50_SCL.

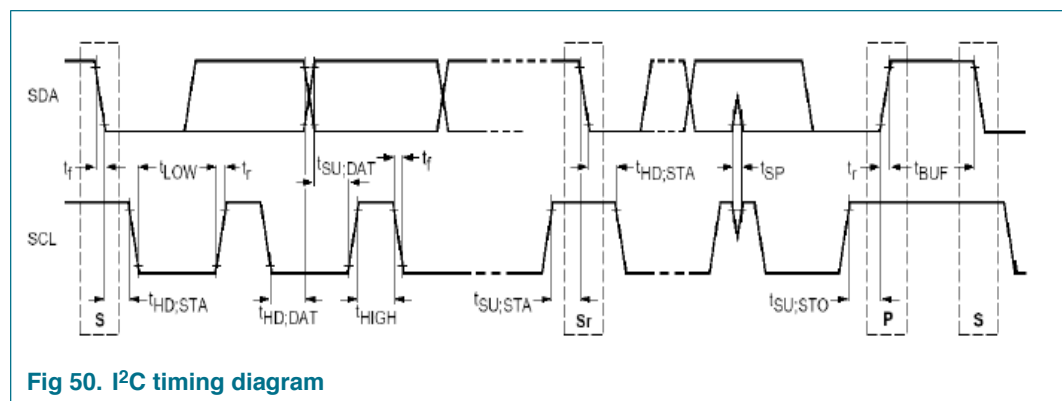
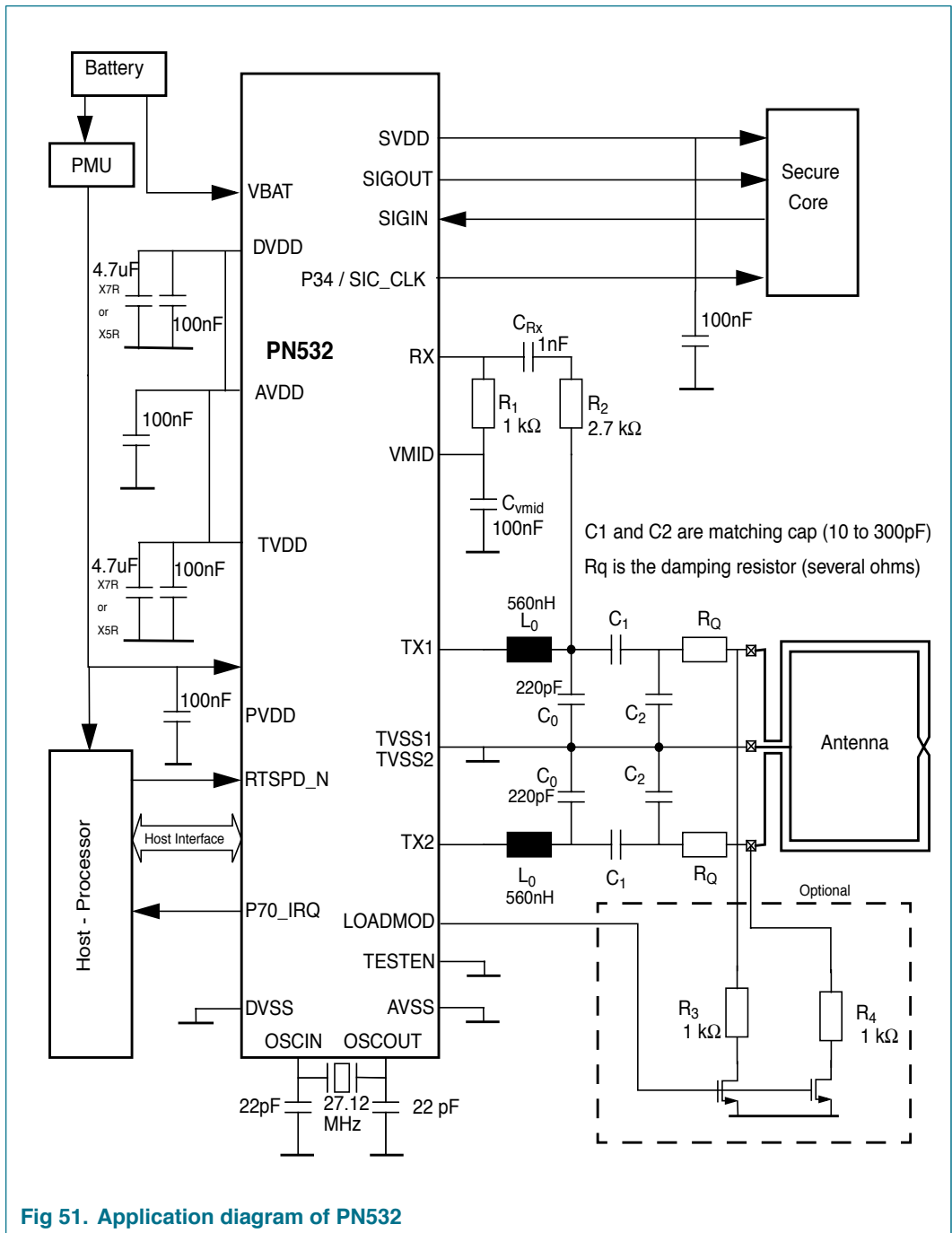

Fig 50. I²C timing diagram

13. Application information



14. Package outline

HVQFN40: plastic thermal enhanced very thin quad flat package; no leads; 40 terminals; body 6 x 6 x 0.85 mm

SOT618-1

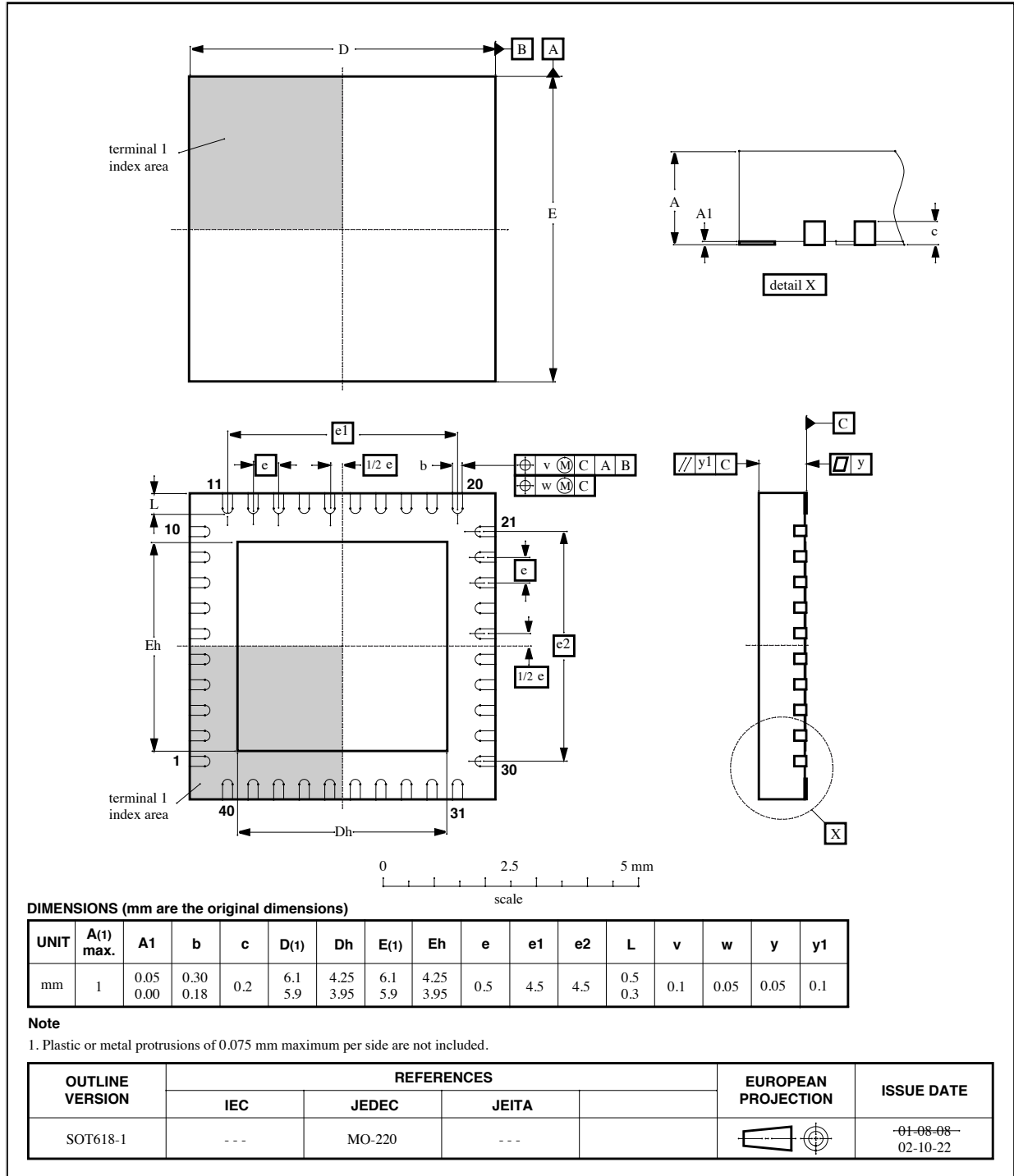

Fig 52. Package outline HVQFN40 (SOT618-1)

This package is MSL level 2.

15. Abbreviations

Table 321. Abbreviations

Acronym	Description
ASK	Amplitude Shift keying
BPSK	Bit Phase Shift Keying
CIU	Contactless Interface Unit
CRC	Cyclic Redundancy Check
ECMA	European Computer Manufacturers Association organization
GPIO	General Purpose Input Output
GPIRQ	General Purpose Interrupt ReQuest
HPD	Hard Power Down (see Section 8.5.3 on page 90)
HSU	High Speed UART
Initiator	Generates RF field at 13.56 MHz and starts the NFCIP-1 communication.
LDO	Low Drop-Out regulator
Load modulation Index	The load modulation index is defined as the card's voltage ratio $(V_{max} - V_{min}) / (V_{max} + V_{min})$ measured at the card's coil.
MIF	Multi InterFace block
Modulation Index	The modulation index is defined as the voltage ratio $(V_{max} - V_{min}) / (V_{max} + V_{min})$.
MSL	Moisture Sensitivity Level
NFCIP	NFC Interface and Protocol
NFC-WI	NFC Wired Interface to connect NFC front end to a SIC
PCD	Proximity Coupling Device. Definition for a Card Reader/ Writer according to the ISO/IEC 14443 Specification
PCR	Power Clock Reset controller
PICC	Proximity Cards. Definition for a contactless Smart Card according to the ISO/IEC 14443 specification
SIC	Secure Integrated Circuit (can be a Smart Card IC, a Secure Access Module (SAM),...)
SPI	Serial Parallel Interface
SPD	Soft Power Down mode (see Section 8.5.4 on page 91)
Target	Responds to initiator command either using load modulation scheme (RF field generated by Initiator) or using modulation of self-generated RF field (no RF field generated by initiator during target answer).
UART	Universal Asynchronous Receive Transmit

16. Revision history

Table 322. Revision history

Document ID	Release date	Data sheet status	Change notice	Supersedes
115410	17 October 2005	Objective data sheet	Initial version	-
115411	24 October 2005	Objective data sheet		Revision 1.0
115412	21 December 2005	Objective data sheet		Revision 1.1
115420	11 May 2006	Preliminary data sheet		Revision 1.2
115421	2 June 2006	Preliminary data sheet		Revision 2.0
115422	16 June 2006	Preliminary data sheet	update for rev1.3	Revision 2.1
115423	17 August 2006	Preliminary data sheet	update for rev1.3 after spec review	Revision 2.2
115430	17 October 2006	Product data sheet	complete review of the specification	Revision 2.3
115431	3 April 2007	Product data sheet		Revision 3.0
115432	3 December 2007	Product data sheet		Revision 3.1

Modifications: Apart from typo corrections:

- General rewording of Mifare designation (e.g. "MIFARE")
- Within the [Section 1 "General description" on page 1](#), [Section 8.6 "Contactless Interface Unit \(CIU\)" on page 98](#), [Section 8.6.3.3 "ISO/IEC 14443B Reader/Writer" on page 104](#), the text related to patent (The use of this NXP IC according to ISO/IEC 14443 B might infringe third party patent rights. A purchaser of this NXP IC has to take care for appropriate third party patent licenses.) has been removed. It is replaced with the [Table 2 "Ordering information" on page 5](#) notes, and the [Section 17.4 "Trademarks" on page 216](#).
- [Table 2 "Ordering information" on page 5](#), notes have been modified.
- P70_IRQ pin description in [Table 3 on page 8](#) has been changed
- Reduced functionality not working in SPI mode added in [Section 8.4 on page 83](#)
- [Table 142 on page 96](#) [Table note 2](#) has been modified
- Remark for the Wired Card mode FeliCa added in [Section 8.6.13.1 on page 123](#)
- VIH of RSTPD_N when PVDD<0.4V aligned between [Section 8.4 on page 83](#) and [Section 12.7 on page 198](#)
- [Table 156 on page 115](#) for RF level detector has been modified
- Functional conditions have been added in [Section 8.6.9 on page 116](#) and in [Section 12.4 on page 197](#).
- [Table 158 on page 117](#), [Table 296 on page 197](#) and [Table 297 on page 197](#) have been modified and aligned
- 2 remarks have been added in [Section 8.6.13.1 on page 123](#)
- [Table 293 on page 195](#) modified the VBAT condition for VDVDD to 3.4V instead of 3.7V.
- [Table 307 on page 203](#) has been modified and a note has been added.
- [Table 315 on page 207](#) for RX characteristics has been modified.

17. Legal information

17.1 Data sheet status

Document status ^{[1][2]}	Product status ^[3]	Definition
Objective [short] data sheet	Development	This document contains data from the objective specification for product development.
Preliminary [short] data sheet	Qualification	This document contains data from the preliminary specification.
Product [short] data sheet	Production	This document contains the product specification.

[1] Please consult the most recently issued document before initiating or completing a design.

[2] The term 'short data sheet' is explained in section "Definitions".

[3] The product status of device(s) described in this document may have changed since this document was published and may differ in case of multiple devices. The latest product status information is available on the Internet at URL <http://www.nxp.com>.

17.2 Definitions

Draft — The document is a draft version only. The content is still under internal review and subject to formal approval, which may result in modifications or additions. NXP Semiconductors does not give any representations or warranties as to the accuracy or completeness of information included herein and shall have no liability for the consequences of use of such information.

Short data sheet — A short data sheet is an extract from a full data sheet with the same product type number(s) and title. A short data sheet is intended for quick reference only and should not be relied upon to contain detailed and full information. For detailed and full information see the relevant full data sheet, which is available on request via the local NXP Semiconductors sales office. In case of any inconsistency or conflict with the short data sheet, the full data sheet shall prevail.

17.3 Disclaimers

General — Information in this document is believed to be accurate and reliable. However, NXP Semiconductors does not give any representations or warranties, expressed or implied, as to the accuracy or completeness of such information and shall have no liability for the consequences of use of such information.

Right to make changes — NXP Semiconductors reserves the right to make changes to information published in this document, including without limitation specifications and product descriptions, at any time and without notice. This document supersedes and replaces all information supplied prior to the publication hereof.

Suitability for use — NXP Semiconductors products are not designed, authorized or warranted to be suitable for use in medical, military, aircraft, space or life support equipment, nor in applications where failure or malfunction of an NXP Semiconductors product can reasonably be expected to result in personal injury, death or severe property or environmental

damage. NXP Semiconductors accepts no liability for inclusion and/or use of NXP Semiconductors products in such equipment or applications and therefore such inclusion and/or use is at the customer's own risk.

Applications — Applications that are described herein for any of these products are for illustrative purposes only. NXP Semiconductors makes no representation or warranty that such applications will be suitable for the specified use without further testing or modification.

Limiting values — Stress above one or more limiting values (as defined in the Absolute Maximum Ratings System of IEC 60134) may cause permanent damage to the device. Limiting values are stress ratings only and operation of the device at these or any other conditions above those given in the Characteristics sections of this document is not implied. Exposure to limiting values for extended periods may affect device reliability.

Terms and conditions of sale — NXP Semiconductors products are sold subject to the general terms and conditions of commercial sale, as published at <http://www.nxp.com/profile/terms>, including those pertaining to warranty, intellectual property rights infringement and limitation of liability, unless explicitly otherwise agreed to in writing by NXP Semiconductors. In case of any inconsistency or conflict between information in this document and such terms and conditions, the latter will prevail.

No offer to sell or license — Nothing in this document may be interpreted or construed as an offer to sell products that is open for acceptance or the grant, conveyance or implication of any license under any copyrights, patents or other industrial or intellectual property rights.

Quick reference data — The Quick reference data is an extract of the product data given in the Limiting values and Characteristics sections of this document, and as such is not complete, exhaustive or legally binding.

17.4 Trademarks

Notice: All referenced brands, product names, service names and trademarks are the property of their respective owners.

MIFARE — is a trademark of NXP B.V.

18. Contact information

For additional information, please visit: <http://www.nxp.com>

For sales office addresses, send an email to: salesaddresses@nxp.com

19. Tables

Table 1. Quick reference data	4	Table 41. Timer2 T2H register (SFR address CDh) bit allocation	30
Table 2. Ordering information	5	Table 42. Description of T2H bits	30
Table 3. PN532 Pin description	8	Table 43. Timer2 RCAP2L register (SFR address CAh) bit allocation	30
Table 4. IDATA memory addressing	12	Table 44. Description of RCAP2L bits	30
Table 5. SFR map of NFC controller	13	Table 45. Timer2 RCAP2H register (SFR address CBh) bit allocation	30
Table 6. Peripheral mapping into XRAM memory space	14	Table 46. Description of RCAP2H bits	30
Table 7. PCON register (SFR: address 87h) bit allocation	16	Table 47. Debug UART SFR register list	32
Table 8. Description of PCON bits	16	Table 48. Debug UART S0CON register (SFR: address 98h) bit allocation	33
Table 9. Interrupt vector	16	Table 49. Description of S0CON bits	33
Table 10. Interrupt controller IE0 register (SFR: address A8h) bit allocation	17	Table 50. Debug UART modes	34
Table 11. Description of IE0 bits	17	Table 51. Debug UART S0BUF Register (SFR: address 99h) bit allocation	35
Table 12. Interrupt controller IE1 register (SFR: address E8h) bit allocation	18	Table 52. Description of S0BUF bits	35
Table 13. Description of IE1 bits	18	Table 53. Baud rates in mode 0	35
Table 14. Interrupt controller IP0 register (SFR: address B8h) bit allocation	19	Table 54. Baud rates in mode 2	35
Table 15. Description of IP0 bits	19	Table 55. Trigger select	36
Table 16. Interrupt controller IP1 register (SFR: address F8h) bit allocation	19	Table 56. Maximum baud rates using mode 2 of Timer1	37
Table 17. Description of IP1 bits	19	Table 57. Baud rates using mode 2 of Timer1 with $f_{CLK} = 27.12$ MHz	37
Table 18. GPIRQ register (address 6107h) bit allocation	20	Table 58. Maximum baud rates using Timer2	38
Table 19. Description of GPIRQ bits	20	Table 59. Timer0/1 Special Function registers List	39
Table 20. Timer0/1 Special Function registers list	21	Table 60. P7CFG register (SFR: address F4h) bit allocation	44
Table 21. Timer0/1 SFR registers CPU state access	22	Table 61. Description of P7CFG bits	44
Table 22. Timer0/1 T01CON register (SFR address 88h), bit allocation	23	Table 62. P7CFGB register (SFR: address F5h) bit allocation	44
Table 23. Description of Timer0/1 T01CON register bits	23	Table 63. Description of P7CFGB bits	44
Table 24. Timer 0/1 T01MOD register (SFR address 89h), bit allocation	24	Table 64. P7 register (SFR: address F7h) bit allocation	45
Table 25. Description of T01MOD bits	24	Table 65. Description of P7 bits	45
Table 26. Timer0/1 T0L register (SFR address 8Ah), bit allocation	25	Table 66. P3CFG register (SFR: address FCh) bit allocation	45
Table 27. Description of T0L bits	25	Table 67. Description of P3CFG bits	45
Table 28. Timer0/1 T0H register (SFR address 8Ch), bit allocation	25	Table 68. P3CFGB register (SFR: address FDh) bit allocation	46
Table 29. Description of T0H bits	25	Table 69. Description of P3CFGB bits	46
Table 30. Timer0/1 T1L register (SFR address 8Bh), bit allocation	26	Table 70. P3 register (SFR: address B0h) bit allocation	47
Table 31. Description of T1L bits	26	Table 71. Description of P3 bits	47
Table 32. Timer0/1 T1H register (SFR address 8Dh), bit allocation	26	Table 72. HOST interface selection	48
Table 33. Description of T1H bits	26	Table 73. Config I0_I1 register (address 6103h) bit allocation	49
Table 34. Timer2 SFR register List	27	Table 74. Description of Config I0_I1 bits	49
Table 35. Timer2 T2CON register (SFR address C8h) bit allocation	28	Table 75. I ² C register list	50
Table 36. Description of T2CON bits	28	Table 76. I ² CCON register (SFR: address D8h) bit allocation	54
Table 37. Timer2 T2MOD register (SFR address C9h) bit allocation	29	Table 77. Description of I ² CCON bits	54
Table 38. Description of T2MOD bits	29	Table 78. I ² CSTA register (SFR: address D9h) bit allocation	57
Table 39. Timer2 T2L register (SFR address CCh) bit allocation	30	Table 79. Description of I ² CSTA bits	57
Table 40. Description of T2L bits	30	Table 80. I ² C Master Transmitter Mode status code	58
		Table 81. I ² C Master Receiver Mode status codes	59
		Table 82. I ² C Slave Receiver Mode status codes	60
		Table 83. I ² C Slave Transmitter Mode status codes	61

Table 84. I ² C Miscellaneous status codes	62	Table 125. Description of SPIstatus bits	82
Table 85. I ² C DAT register (SFR: address DAh) bit allocation.	63	Table 126. LDO register- (address 6109h) bit allocation	87
Table 86. Description of I ² C DAT bits	63	Table 127. Description of LDO bits	87
Table 87. I ² C ADR register (SFR: address DBh) bit allocation.	64	Table 128. Control_switch_rng register (address 6106h) bit allocation	88
Table 88. Description of I ² C ADR bits	64	Table 129. Description of Control_switch_rng bits	88
Table 89. I ² C_wu_control register (address 610Ah) bit allocation.	64	Table 130. PN532 clock source characteristics	89
Table 90. Description of I ² C_wu_control bits	64	Table 131. Current consumption in low power modes	91
Table 91. Fifo manager SFR register list	66	Table 132. PCR registers.	92
Table 92. RWL register (SFR: address 9Ah) bit allocation.	66	Table 133. PCR CFR register- (address 6200h) bit allocation	93
Table 93. Description of RWL bits	66	Table 134. Description of PCR CFR bits	93
Table 94. TWL register (SFR: address 9Bh) bit allocation	66	Table 135. PCR CER register (address 6201h) bit allocation	93
Table 95. Description of TWL bits	66	Table 136. Description of PCR CER bits	93
Table 96. FIFOFS register (SFR: address 9Ch) bit allocation.	67	Table 137. PCR ILR register (address 6202h) bit allocation	94
Table 97. Description of FIFOFS register bits	67	Table 138. Description of PCR ILR bits	94
Table 98. FIFOFF register (SFR: address 9Dh) bit allocation.	67	Table 139. PCR Control register (address 6203h) bit allocation	95
Table 99. Description of FIFOFF bits	67	Table 140. Description of PCR Control bits	95
Table 100. SFF register (SFR: address 9Eh) bit allocation.	68	Table 141. PCR Status register (address 6204h) bit allocation	95
Table 101. Description of SFF bits	68	Table 142. Description of PCR Status bits	96
Table 102. FIT register (SFR: address 9Fh) bit allocation.	69	Table 143. PCR Wakeupen register (address 6205h) bit allocation	96
Table 103. Description of FIT bits	69	Table 144. Description of PCR Wakeupen bits	96
Table 104. FITEN register (SFR: address A1h) bit allocation.	70	Table 145. Communication overview for ISO/IEC 14443A/MIFARE Reader/Writer	101
Table 105. Description of FITEN bits	70	Table 146. Communication overview for FeliCa Reader/Writer	103
Table 106. FDATA register (SFR: address A2h) bit allocation.	71	Table 147. FeliCa Framing and Coding	103
Table 107. Description of FDATA bits	71	Table 148. FeliCa framing and coding	103
Table 108. FSIZE register (SFR: address A3h) bit allocation.	71	Table 149. Communication overview for ISO/IEC 14443B Reader/Writer	104
Table 109. Description of FSIZE bits	71	Table 150. Communication overview for NFC Active Communication mode	106
Table 110. HSU SFR register list	73	Table 151. Communication overview for NFC Passive Communication mode	107
Table 111. HSU_STA register (SFR: address ABh) bit allocation.	75	Table 152. Communication overview for ISO/IEC 14443A/MIFARE Card operating mode	109
Table 112. Description of HSU_STA bits	75	Table 153. Communication overview for FeliCa Card operating mode	110
Table 113. HSU_CTR register (SFR: address Ach) bit allocation.	76	Table 154. Settings for TX1	113
Table 114. Description of HSU_CTR bits	76	Table 155. Settings for TX2	113
Table 115. HSU_PRE register (SFR: address ADh) bit allocation.	77	Table 156. Setting of the RF level detector	115
Table 116. Description of HSU_PRE bits	77	Table 157. andet_control register (address 610Ch) bit allocation	117
Table 117. HSU_CNT register (SFR: address AEh) bit allocation.	77	Table 158. Description of andet_control bits	117
Table 118. Description of HSU_CNT bits	77	Table 159. Data_rng register (address 6105h) bit allocation	118
Table 119. Recommendation for HSU data rates	77	Table 160. Description of Data_rng bits	118
Table 120. SPI SFR register list	78	Table 161. Control_switch_rng register (address 6106h) bit allocation	118
Table 121. SPI operation	78	Table 162. Description of Control_switch_rng bits	118
Table 122. SPIcontrol register (SFR: address A9h) bit allocation.	80	Table 163. NFC_WI_control register (address 610Eh) bit allocation	125
Table 123. Description of SPIcontrol bits	80	Table 164. Description of NFC_WI_control bits	125
Table 124. SPIstatus register (SFR: address AAh) bit allocation.	82		

Table 165. High priority interrupt sources (CIU_IRQ_0)	131	Table 206. CIU_Mode register (address 6301h) bit allocation	156
Table 166. Low priority interrupt sources (CIU_IRQ_1)	131	Table 207. Description of CIU_Mode bits	156
Table 167. Command overview	133	Table 208. CIU_TxMode register (address 6302h) bit allocation	157
Table 168. Transceive command scenario	135	Table 209. Description of CIU_TxMode bits	157
Table 169. Observe_testbus register (address 6104h) bit allocation	140	Table 210. CIU_RxMode register (address 6303h) bit allocation	158
Table 170. Description of Observe_testbus bits	140	Table 211. Description of CIU_RxMode bits	158
Table 171. TstBusBitSel set to 07h	140	Table 212. CIU_TxControl register (address 6304h) bit allocation	159
Table 172. TstBusBitSel set to 0Dh	140	Table 213. Description of CIU_TxControl bits	159
Table 173. Contactless Interface Unit SFR memory map	142	Table 214. CIU_TxAuto register (address 6305h) bit allocation	160
Table 174. Contactless Interface Unit extension memory map	142	Table 215. Description of CIU_TxAuto bits	160
Table 175. Behavior of register bits	144	Table 216. CIU_TxSel register (address 6306h) bit allocation	161
Table 176. CIU_SIC_CLK_en register (address 6330h) bit allocation	144	Table 217. Description of CIU_TxSel bits	161
Table 177. Description of CIU_SIC_CLK_en bits	144	Table 218. CIU_RxSel register (address 6307h) bit allocation	162
Table 178. CIU_Command register (address D1h or 6331h) bit allocation	145	Table 219. Description of CIU_RxSel bits	162
Table 179. Description of CIU_Command bits	145	Table 220. CIU_RxThreshold register (address 6308h) bit allocation	163
Table 180. CIU_CommIEn register (address D2h or 6332h) bit allocation	146	Table 221. Description of CIU_RxThreshold bits	163
Table 181. Description of CIU_CommIEn bits	146	Table 222. CIU_Demod register (address 6309h) bit allocation	163
Table 182. CIU_DivIEn register (address D3h or 6333h) bit allocation	146	Table 223. Description of CIU_Demod bits	163
Table 183. Description of CIU_DivIEn bits	146	Table 224. CIU_FelNFC1 register (address 630Ah) bit allocation	164
Table 184. CIU_CommIrq register (address D4h or 6334h) bit allocation	147	Table 225. Description of CIU_FelNFC1 bits	164
Table 185. Description of CIU_CommIReq bits	147	Table 226. CIU_FelNFC2 register (address 630Bh) bit allocation	165
Table 186. CIU_DivIrq register (address D5h or 6335h) bit allocation	148	Table 227. Description of CIU_FelNFC2 bits	165
Table 187. Description of CIU_DivIrq bits	148	Table 228. CIU_MifNFC register (address 630Ch) bit allocation	166
Table 188. CIU_Error register (address D6h or 6336h) bit allocation	149	Table 229. Description of CIU_MifNFC bits	166
Table 189. Description of CIU_Error bits	149	Table 230. CIU_ManualRCV register (address 630Dh) bit allocation	167
Table 190. CIU_Status1 register (address DFh or 6337h) bit allocation	150	Table 231. Description of CIU_ManualRCV bits	167
Table 191. Description of CIU_Status1 bits	150	Table 232. CIU_TypeB register (address 630Eh) bit allocation	169
Table 192. CIU_Status2 register (address E9h or 6338h) bit allocation	151	Table 233. Description of CIU_TypeB bits	169
Table 193. Description of CIU_Status2 bits	151	Table 234. CIU_CRCResultMSB register (address 6311h) bit allocation	170
Table 194. CIU_FIFOData register (address EAh or 6339h) bit allocation	152	Table 235. Description of CIU_CRCResultMSB bits	170
Table 195. Description of CIU_FIFOData bits	152	Table 236. CIU_CRCResultLSB register (address 6312h) bit allocation	170
Table 196. CIU_FIFOLevel register (address EBh or 633Ah) bit allocation	152	Table 237. Description of CIU_CRCResultLSB bits	170
Table 197. Description of CIU_FIFOLevel bits	152	Table 238. CIU_GsNOff register (address 6313h) bit allocation	171
Table 198. CIU_WaterLevel register (address Ech or 633Bh) bit allocation	153	Table 239. Description of CIU_GsNOff bits	171
Table 199. Description of CIU_WaterLevel bits	153	Table 240. CIU_ModWidth register (address 6314h) bit allocation	172
Table 200. CIU_Control register (address EDh or 633Ch) bit allocation	153	Table 241. Description of CIU_ModWidth bits	172
Table 201. Description of CIU_Control bits	153	Table 242. CIU_TxBitPhase register (address 6315h) bit allocation	173
Table 202. CIU_BitFraming register (address Eeh or 633Dh) bit allocation	154	Table 243. Description of CIU_TxBitPhase bits	173
Table 203. Description of CIU_BitFraming bits	154		
Table 204. CIU_Coll register (address EFh or 633Eh) bit allocation	155		
Table 205. Description of CIU_Coll bits	155		

Table 244. CIU_RFCfg register (address 6316h) bit allocation.	174	Table 282. CIU_TestDAC2 register (address 632Ah) bit allocation	186
Table 245. Description of CIU_RFCfg bits	174	Table 283. Description of CIU_TestDAC2 bits	186
Table 246. CIU_GsNOn register (address 6317h) bit allocation.	175	Table 284. CIU_TestADC register (address 632Bh) bit allocation	186
Table 247. Description of CIU_GsNOn bits	175	Table 285. Description of CIU_TestADC bits	186
Table 248. CIU_CWGsP register (address 6318h) bit allocation.	176	Table 286. CIU_RFlevelDet register (address 632Fh) bit allocation	187
Table 249. Description of CIU_CWGsP bits	176	Table 287. Description of CIU_RFlevelDet bits	187
Table 250. CIU_ModGsP register (address 6319h) bit allocation.	176	Table 288. Standard registers mapping	188
Table 251. Description of CIU_ModGsP bits	176	Table 289. SFR registers mapping	191
Table 252. CIU_TMode register (address 631Ah) bit allocation.	177	Table 290. Limiting values	194
Table 253. Description of CIU_TMode bits	177	Table 291. Operating conditions	194
Table 254. CIU_TPrescaler register (address 631Bh) bit allocation.	178	Table 292. Thermal characteristics	194
Table 255. Description of CIU_TPrescaler bits	178	Table 293. Power management characteristics	195
Table 256. CIU_TReloadVal_hi register (address 631Ch) bit allocation.	178	Table 294. Overcurrent detection characteristics.	195
Table 257. Description of CIU_TReloadVal_hi bits	178	Table 295. Current consumption characteristics	196
Table 258. CIU_TReload_lo register (address 631Dh) bit allocation.	179	Table 296. Antenna presence detection lower levels characteristics	197
Table 259. Description of CIU_TReload_lo bits	179	Table 297. Antenna Presence Detection Upper Levels characteristics	197
Table 260. CIU_TCounterVal_hi register (address 631Eh) bit allocation.	179	Table 298. Crystal requirements	197
Table 261. Description of CIU_TCounterVal_hi bits	179	Table 299. Pin characteristics for 27.12 MHz XTAL Oscillator (OSCIN, OSCOUT)	198
Table 262. CIU_TCounterVal_lo register (address 631Fh) bit allocation.	179	Table 300. RSTPD_N input pin characteristics	198
Table 263. Description of CIU_TCounterVal_lo bits	179	Table 301. Input pin characteristics for I0, I1 and TESTEN	199
Table 264. CIU_TestSel1 register (address 6321h) bit allocation.	180	Table 302. RSTOUT_N output pin characteristics	199
Table 265. Description of CIU_TestSel1 bits	180	Table 303. Input/output pin characteristics for pin P70_IRQ	200
Table 266. CIU_TestSel2 register (address 6322h) bit allocation.	181	Table 304. Input/output pin characteristics for P30 / UART_RX, P31 / UART_TX, P32_INT0, P33_INT1	201
Table 267. Description of CIU_TestSel2 bits	181	Table 305. Input/output pin characteristics for P34 / SIC_CLK	202
Table 268. CIU_TestPinEn register (address 6323h) bit allocation.	181	Table 306. Input/output pin characteristics for P35	202
Table 269. Description of CIU_TestPinEn bits	181	Table 307. Input pin characteristics for NSS / HSU_RX for HSU / SPI interfaces	203
Table 270. CIU_TestPinValue register (address 6324h) bit allocation.	182	Table 308. Input/open drain output pin characteristics for P50_SCL for I ² C interface	203
Table 271. Description of CIU_TestPinValue bits	182	Table 309. Input/output pin characteristics for MOSI / HSU_TX for HSU and SPI Interfaces.	204
Table 272. CIU_TestBus register (address 6325h) bit allocation.	182	Table 310. Input/open drain output pin characteristics for SDA for I ² C interface	204
Table 273. Description of CIU_TestBus bits	182	Table 311. Input/output pin characteristics for MISO / P71 and SCK / P72	205
Table 274. CIU_AutoTest register (address 6326h) bit allocation.	183	Table 312. Input/output pin characteristics for SIGIN.	205
Table 275. Description of CIU_AutoTest bits	183	Table 313. Output pin characteristics for SIGOUT.	206
Table 276. CIU_Version register (address 6327h) bit allocation.	183	Table 314. Output pin characteristics for LOADMOD	206
Table 277. Description of CIU_Version bits	183	Table 315. Input pin characteristics for RX	207
Table 278. CIU_AnalogTest register (address 6328h) bit allocation.	184	Table 316. Output pin characteristics for AUX1/AUX2.	208
Table 279. Description of CIU_AnalogTest bits	184	Table 317. Output pin characteristics for TX1/TX2	208
Table 280. CIU_TestDAC1 register (address 6329h) bit allocation.	186	Table 318. Reset duration time	209
Table 281. Description of CIU_TestDAC1 bits	186	Table 319. SPI timing specification	210
		Table 320. I ² C timing specification.	211
		Table 321. Abbreviations	214
		Table 322. Revision history	215

20. Figures

Fig 1. Block diagram of PN532	6	Fig 45. Signal shape for SIGIN in NFC-WI mode	124
Fig 2. Pin configuration for HVQFN 40 (SOT618-1)	7	Fig 46. AutoColl command	137
Fig 3. PN532 80C51 block description	10	Fig 47. RX Voltage definitions	208
Fig 4. PN532 memory map overview	11	Fig 48. Timings for reset overview	209
Fig 5. Indirect addressing of XRAM memory space	15	Fig 49. SPI timing diagram	210
Fig 6. Open-drain	40	Fig 50. I ² C timing diagram	211
Fig 7. Quasi Bidirectional	41	Fig 51. Application diagram of PN532	212
Fig 8. Input	42	Fig 52. Package outline HVQFN40 (SOT618-1)	213
Fig 9. Push-pull output	43		
Fig 10. Host interface block diagram	48		
Fig 11. I ² C state machine of status behavior	57		
Fig 12. FIFO manager block diagram	65		
Fig 13. HSU block diagram	73		
Fig 14. Memory manager shift register management	78		
Fig 15. SPI Status register read access	79		
Fig 16. SPI FIFO manager read access	79		
Fig 17. SPI FIFO manager write access	80		
Fig 18. SPI Data transfer format	81		
Fig 19. Power management scheme	83		
Fig 20. LDO block diagram	84		
Fig 21. Graph of DVDD versus VBAT with offset	85		
Fig 22. Graph of DVDD versus VBAT in Soft-Power-Down mode with offset	85		
Fig 23. Graph of DVDD versus VBAT without offset	86		
Fig 24. 27.12 MHz crystal oscillator connection	90		
Fig 25. Remote wake-up from Power-down with P33 as wake-up source	92		
Fig 26. Simplify Contactless Interface Unit (CIU) block diagram	100		
Fig 27. ISO/IEC 14443A/MIFARE Reader/Writer communication diagram	101		
Fig 28. Data coding and framing according to ISO/IEC 14443A	102		
Fig 29. FeliCa Reader/Writer communication diagram	103		
Fig 30. ISO/IEC 14443B Reader/Writer communication diagram	104		
Fig 31. NFCIP-1 mode	105		
Fig 32. Active NFC mode	106		
Fig 33. Passive NFC mode	107		
Fig 34. ISO/IEC 14443A/MIFARE card operating mode communication diagram	109		
Fig 35. FeliCa card operating mode communication diagram	110		
Fig 36. CIU detailed block diagram	111		
Fig 37. Disconnection localization for the antenna detection	116		
Fig 38. Data mode detector	119		
Fig 39. Serial data switch for TX1 and TX2	120		
Fig 40. Serial data switch for LOADMOD pin	121		
Fig 41. Communication flows supported by the NFC-WI interface	122		
Fig 42. Signal shape for SIGOUT in FeliCa secure IC mode	123		
Fig 43. Signal shape for SIGIN in FeliCa secure IC mode	123		
Fig 44. Signal shape for SIGOUT in NFC-WI mode	124		

21. Contents

1	General description	1	8.2.2	GPIO registers description	44
2	Features	3	8.2.2.1	P7CFGA register	44
3	Applications	4	8.2.2.2	P7CFGB register	44
4	Quick reference data	4	8.2.2.3	P7 register	45
5	Ordering information	5	8.2.2.4	P3CFGA register	45
6	Block diagram	6	8.2.2.5	P3CFGB register	46
7	Pinning information	7	8.2.2.6	P3 register	47
7.1	Pinning	7	8.3	Host interfaces	48
7.2	Pin description	8	8.3.1	Multi-InterFace (MIF) description	48
8	Functional description	10	8.3.1.1	MIF register	49
8.1	80C51	10	8.3.1.2	Configuration modes of the host interface pins.	49
8.1.1	PN532 memory map	11	8.3.2	I ² C interface	50
8.1.2	Data memory	12	8.3.2.1	I ² C functional description	50
8.1.2.1	IDATA memory	12	8.3.2.2	Master transmitter mode	51
8.1.2.2	XRAM memory	14	8.3.2.3	Master receiver mode.	51
8.1.3	Program memory	15	8.3.2.4	Slave receiver mode.	52
8.1.4	PCON module.	16	8.3.2.5	Slave transmitter mode	53
8.1.5	Interrupt Controller	16	8.3.2.6	I ² C wake-up mode	53
8.1.5.1	Interrupt vectors	16	8.3.2.7	I ² C CON register	54
8.1.5.2	Interrupt enable: IE0 and IE1 registers.	17	8.3.2.8	I ² C STA register.	57
8.1.5.3	Interrupt prioritization: IP0 and IP1 registers	18	8.3.2.9	I ² C DAT register.	63
8.1.5.4	General purpose IRQ control	20	8.3.2.10	I ² CADR register	64
8.1.6	Timer0/1 description	21	8.3.2.11	I ² C_wu_control register	64
8.1.6.1	Timer0/1 registers.	21	8.3.3	FIFO manager	65
8.1.6.2	T01CON register.	23	8.3.3.1	FIFO manager functional description	65
8.1.6.3	T01MOD register	24	8.3.3.2	RWL register	66
8.1.6.4	T0L and T0H registers	25	8.3.3.3	TWL register.	66
8.1.6.5	T1L and T1H registers	26	8.3.3.4	FIFOFS register	67
8.1.6.6	Incrementer.	26	8.3.3.5	FIFOFF register	67
8.1.6.7	Overflow detection	27	8.3.3.6	SFF register	68
8.1.7	Timer2 description	27	8.3.3.7	FIT register.	69
8.1.7.1	Timer2 registers	27	8.3.3.8	FITEN register	70
8.1.7.2	T2CON register.	28	8.3.3.9	FDATA register	71
8.1.7.3	T2MOD register	29	8.3.3.10	FSIZE register	71
8.1.7.4	T2L, T2H registers	30	8.3.4	HIGH SPEED UART (HSU)	72
8.1.7.5	RCAP2L, RCAP2H registers	30	8.3.4.1	Mode of operation	74
8.1.8	Debug UART	31	8.3.4.2	HSU Baud rate generator.	74
8.1.8.1	Feature list	31	8.3.4.3	HSU preamble filter	74
8.1.8.2	Debug UART functional description	31	8.3.4.4	HSU wake-up generator.	75
8.1.8.3	S0CON register	33	8.3.4.5	HSU_STA register	75
8.1.8.4	S0BUF register.	35	8.3.4.6	HSU_CTR register	76
8.1.8.5	Mode 0 baud rate	35	8.3.4.7	HSU_PRE register	77
8.1.8.6	Mode 2 baud rate	35	8.3.4.8	HSU_CNT register.	77
8.1.8.7	Mode 1 and 3 baud rates	36	8.3.5	Serial Parallel Interface (SPI)	78
8.1.8.8	Baud rates using Timer1 (Debug UART mode 1 and 3)	36	8.3.5.1	Shift register pointer.	78
8.1.8.9	Baud rates using Timer2 (Debug UART mode 1 and 3)	38	8.3.5.2	Protocol	79
8.2	General purpose IOs configurations.	38	8.3.5.3	SPI status register read	79
8.2.1	Pad configurations description	40	8.3.5.4	FIFO manager read access	79
8.2.1.1	Open-drain	40	8.3.5.5	FIFO manager write access.	80
8.2.1.2	Quasi Bidirectional	41	8.3.5.6	SPIcontrol register	80
8.2.1.3	Input	42	8.3.5.7	SPIstatus register.	82
8.2.1.4	Push-pull output	43	8.4	Power management	83
			8.4.1	Low drop-out voltage regulator.	84
			8.4.1.1	LDO block diagram.	84
			8.4.1.2	LDO with offset.	85

8.4.1.3	LDO without offset	86	8.6.15	CRC co-processor	127
8.4.1.4	LDO overcurrent detection	86	8.6.16	FIFO buffer	127
8.4.1.5	LDO register	87	8.6.16.1	Accessing the FIFO buffer	127
8.4.2	SVDD switch	88	8.6.16.2	Controlling the FIFO buffer	127
8.5	Power clock and reset controller	89	8.6.16.3	Status information about the FIFO buffer	128
8.5.1	PCR block diagram	89	8.6.17	CIU_timer	129
8.5.2	27.12 MHz crystal oscillator	90	8.6.18	Interrupt request system	130
8.5.3	Reset modes	90	8.6.18.1	Interrupt sources	130
8.5.4	Soft-Power-Down mode (SPD)	91	8.6.19	CIU Power Reduction Modes	131
8.5.5	Low power modes	91	8.6.19.1	Hard-Power-Down	131
8.5.6	Remote wake-up from SPD	92	8.6.19.2	CIU Power-down	131
8.5.7	PCR extension registers	92	8.6.19.3	Transmitter Power-down	132
8.5.8	PCR register description	93	8.6.20	CIU command set	132
8.5.8.1	CFR register	93	8.6.20.1	General description	132
8.5.8.2	CER register	93	8.6.20.2	General behavior	132
8.5.8.3	ILR register	94	8.6.20.3	Commands overview	133
8.5.8.4	PCR Control register	95	8.6.20.4	Idle command	133
8.5.8.5	PCR Status register	95	8.6.20.5	Config command	133
8.5.8.6	PCR Wakeupen register	96	8.6.20.6	Generate RandomID command	134
8.6	Contactless Interface Unit (CIU)	98	8.6.20.7	CalcCRC command	134
8.6.1	Feature list	99	8.6.20.8	Transmit command	134
8.6.2	Simplified block diagram	100	8.6.20.9	NoCmdChange command	134
8.6.3	Reader/Writer modes	101	8.6.20.10	Receive command	135
8.6.3.1	ISO/IEC 14443A Reader/Writer	101	8.6.20.11	Transceive command	135
8.6.3.2	FeliCa Reader/Writer	103	8.6.20.12	AutoColl command	136
8.6.3.3	ISO/IEC 14443B Reader/Writer	104	8.6.20.13	MFAuthent command	138
8.6.4	ISO/IEC 18092, ECMA 340 NFCIP-1 operating mode	105	8.6.20.14	SoftReset command	138
8.6.4.1	ACTIVE Communication mode	106	8.6.21	CIU tests signals	139
8.6.4.2	PASSIVE Communication mode	107	8.6.21.1	CIU self-test	139
8.6.4.3	NFCIP-1 framing and coding	108	8.6.21.2	CIU test bus	140
8.6.4.4	NFCIP-1 protocol support	108	8.6.21.3	Test signals at pin AUX	141
8.6.5	Card operating modes	109	8.6.21.4	PRBS	141
8.6.5.1	ISO/IEC 14443A/MIFARE card operating mode	109	8.6.22	CIU memory map	142
8.6.5.2	FeliCa Card operating mode	110	8.6.23	CIU register description	144
8.6.6	Overall CIU block diagram	110	8.6.23.1	CIU register bit behavior	144
8.6.7	Transmitter control	112	8.6.23.2	CIU_SIC_CLK_en register (6330h)	144
8.6.8	RF level detector	115	8.6.23.3	CIU_Command register (D1h or 6331h)	145
8.6.9	Antenna presence self test	116	8.6.23.4	CIU_CommIEn register (D2h or 6332h)	146
8.6.9.1	Principle	116	8.6.23.5	CIU_DivIEn register (D3h or 6333h)	146
8.6.9.2	Antenna presence detector register	117	8.6.23.6	CIU_CommIrq register (D4h or 6334h)	147
8.6.10	Random generator	118	8.6.23.7	CIU_DivIrq register (D5h or 6335h)	148
8.6.11	Data mode detector	119	8.6.23.8	CIU_Error register (D6h or 6336h)	149
8.6.12	Serial data switch	120	8.6.23.9	CIU_Status1 register (DFh or 6337h)	150
8.6.12.1	Serial data switch for driver and loadmod	120	8.6.23.10	CIU_Status2 register (E9h or 6338h)	151
8.6.13	NFC-WI/S ² C interface support	122	8.6.23.11	CIU_FIFOData register (EAh or 6339h)	152
8.6.13.1	Signal shape for FeliCa NFC-WI/S ² C interface support	123	8.6.23.12	CIU_FIFOLevel register (EBh or 633Ah)	152
8.6.13.2	Signal shape for ISO/IEC14443A and MIFARE NFC-WI/S ² C support	124	8.6.23.13	CIU_WaterLevel register (ECh or 633Bh)	153
8.6.13.3	NFC-WI/S ² C initiator mode	125	8.6.23.14	CIU_Control register (EDh or 633Ch)	153
8.6.14	Hardware support for FeliCa and NFC polling	125	8.6.23.15	CIU_BitFraming register (EEh or 633Dh)	154
8.6.14.1	Polling sequence functionality for initiator	125	8.6.23.16	CIU_Coll register (EFh or 633Eh)	155
8.6.14.2	Polling sequence functionality for target	126	8.6.23.17	CIU_Mode register (6301h)	156
8.6.14.3	Additional hardware support for FeliCa and NFC	126	8.6.23.18	CIU_TxMode register (6302h)	157
			8.6.23.19	CIU_RxMode register (6303h)	158
			8.6.23.20	CIU_TxControl register (6304h)	159
			8.6.23.21	CIU_TxAuto register (6305h)	160
			8.6.23.22	CIU_TxSel register (6306h)	161
			8.6.23.23	CIU_RxSel register (6307h)	162
			8.6.23.24	CIU_RxThreshold register (6308h)	163

8.6.23.25	CIU_Demod register (6309h)	163	12.10	Input/output characteristics for pin P70_IRQ	200
8.6.23.26	CIU_FelNFC1 register (630Ah)	164	12.11	Input/output pin characteristics for P30 / UART_RX, P31 / UART_TX, P32_INT0, P33_INT1	201
8.6.23.27	CIU_FelNFC2 register (630Bh)	165	12.12	Input/output pin characteristics for P34 / SIC_CLK	202
8.6.23.28	CIU_MifNFC register (630Ch)	166	12.13	Input/output pin characteristics for P35	202
8.6.23.29	CIU_ManualRCV register (630Dh)	167	12.14	Input pin characteristics for NSS / P50_SCL / HSU_RX	203
8.6.23.30	CIU_TypeB register (630Eh)	169	12.15	Input/output pin characteristics for MOSI / SDA / HSU_TX	204
8.6.23.31	CIU_CRCResultMSB register (6311h)	170	12.16	Input/output pin characteristics for MISO / P71 and SCK / P72	205
8.6.23.32	CIU_CRCResultLSB register (6312h)	170	12.17	Input pin characteristics for SIGIN	205
8.6.23.33	CIU_GsNOff register (6313h)	171	12.18	Output pin characteristics for SIGOUT	206
8.6.23.34	CIU_ModWidth register (6314h)	172	12.19	Output pin characteristics for LOADMOD	206
8.6.23.35	CIU_TxBitPhase register (6315h)	173	12.20	Input pin characteristics for RX	207
8.6.23.36	CIU_RFCfg register (6316h)	174	12.21	Output pin characteristics for AUX1/AUX2	208
8.6.23.37	CIU_GsNOn register (6317h)	175	12.22	Output pin characteristics for TX1/TX2	208
8.6.23.38	CIU_CWGsP register (6318h)	176	12.23	Timing for Reset and Hard-Power-Down	209
8.6.23.39	CIU_ModGsP register (6319h)	176	12.24	Timing for the SPI compatible interface	210
8.6.23.40	CIU_TMode register (631Ah)	177	12.25	Timing for the I ² C interface	211
8.6.23.41	CIU_TPrescaler register (631Bh)	178	13	Application information	212
8.6.23.42	CIU_TReload_hi register (631Ch)	178	14	Package outline	213
8.6.23.43	CIU_TReloadVal_lo register (631Dh)	179	15	Abbreviations	214
8.6.23.44	CIU_TCounterVal_hi register (631Eh)	179	16	Revision history	215
8.6.23.45	Register CIU_TCounterVal_lo (631Fh)	179	17	Legal information	216
8.6.23.46	CIU_TestSel1 register (6321h)	180	17.1	Data sheet status	216
8.6.23.47	CIU_TestSel2 register (6322h)	181	17.2	Definitions	216
8.6.23.48	CIU_TestPinEn register (6323h)	181	17.3	Disclaimers	216
8.6.23.49	CIU_TestPinValue register (6324h)	182	17.4	Trademarks	216
8.6.23.50	CIU_TestBus register (6325h)	182	18	Contact information	216
8.6.23.51	CIU_AutoTest register (6326h)	183	19	Tables	217
8.6.23.52	CIU_Version register (6327h)	183	20	Figures	221
8.6.23.53	CIU_AnalogTest register (6328h)	184	21	Contents	222
8.6.23.54	CIU_TestDAC1 register (6329h)	186			
8.6.23.55	CIU_TestDAC2 register (632Ah)	186			
8.6.23.56	CIU_TestADC register (632Bh)	186			
8.6.23.57	CIU_RFlevelDet register (632Fh)	187			
8.7	Registers map	187			
8.7.1	Standard registers	188			
8.7.2	SFR registers	191			
9	Limiting values	194			
10	Recommended operating conditions	194			
11	Thermal characteristics	194			
12	Characteristics	195			
12.1	Power management characteristics	195			
12.2	Overcurrent detection	195			
12.3	Current consumption characteristics	196			
12.4	Antenna presence self test thresholds	197			
12.5	Typical 27.12 MHz Crystal requirements	197			
12.6	Pin characteristics for 27.12 MHz XTAL Oscillator (OSCIN, OSCOUT)	198			
12.7	RSTPD_N input pin characteristics	198			
12.8	Input pin characteristics for I0 and I1	199			
12.9	RSTOUT_N output pin characteristics	199			

Please be aware that important notices concerning this document and the product(s) described herein, have been included in section 'Legal information'.

